

**Digitronik Line  
SDC100 Series**

**Product  
Manual**

**Digital Indicating Controller**



**CONTENTS**

1. MODEL NUMBER TABLE .....	1
2. SPECIFICATIONS .....	2
3. EXTERNAL DIMENSIONS AND PANEL CUTOUT DIMENSIONS .....	6
4. INSTALLATION .....	6
5. CONNECTIONS .....	7
6. PREPARATION FOR OPERATION .....	11
7. APPEARANCE, NAMES OF COMPONENT PARTS, AND CONTROL CONSTANT SETTING ASSEMBLY .....	13
8. SETTING AND ADJUSTMENT OF VARIOUS CONTROL CONSTANTS .....	16
9. ATTACHED FIGURE: Control Constant Setting Scale Characteristics .....	21
10. MAINTENANCE CHECK .....	27

1  
虎番

# MODEL NUMBER TABLE

Model Number Table I II III IV V

Code No.	Model No.	Specifications					
I	Basic model numbers	SDC100	Local indicating controller				
		SDC101	Local indicating controller/alarm				
		SDC102	Remote/local indicating controller				
		SDC103	Remote/local indicating controller/alarm				
II	Control action output	4Y	Indicator	Indicator only for indication without control function	Applicable to SDC100 and 101 only		
		0A	ON-OFF	Relay output			
		0B	Time proportional + manual reset	Relay output			
		6B	Time proportional + manual reset	Voltage output			
		3H	Heat (time proportional) + cool (time proportional) + manual reset	Relay output + relay output			
		9H	Heat (time proportional) + cool (time proportional) + manual reset	Voltage output + relay output			
		0D	Time proportional PID	Relay output			
		6D	Time proportional PID	Voltage output			
		2G	Position proportional PID	Modutrol motor driving relay output			
		5G	Continuous PID	Current output			
III	Input type range	Input type		Range	Resolution	Indication accuracy (under reference condition)	
		E04	Thermocouple E	0 to 400°C	1°C	±0.5%FS±1 digit	
		E08	Thermocouple E	0 to 800°C	1°C	±0.5%FS±1 digit	
		J04	Thermocouple J	0 to 400°C	1°C	±0.5%FS±1 digit	
		J06	Thermocouple J	0 to 600°C	1°C	±0.5%FS±1 digit	
		K04	Thermocouple K	0 to 400°C	1°C	±0.5%FS±1 digit	
		K08	Thermocouple K	0 to 800°C	1°C	±0.5%FS±1 digit	
		K09	Thermocouple K	0 to 1200°C	1°C	±0.5%FS±1 digit	
		T47	Thermocouple T	-100 to 300°C	1°C	±0.5%FS±1 digit	
		B18	Thermocouple B	0 to 1800°C	1°C	0 to 400°C Not specified 400 to 700°C± 3%FS±1 digit 700 to 1800°C±0.5%FS±1 digit	
		D19	Thermocouple PR40-20	0 to 1900°C	1°C	0 to 600°C± 3%FS±1 digit 600 to 1900°C± 1%FS±1 digit	
		R16	Thermocouple R	0 to 1600°C	1°C	0 to 300°C±1.5%FS±1 digit 300 to 1600°C±0.5%FS±1 digit	
		S16	Thermocouple S	0 to 1600°C	1°C	0 to 500°C±2.5%FS±1 digit 500 to 1600°C±0.5%FS±1 digit	
		W20	Thermocouple WRe5-26	*1 0 to 2000°C	1°C	0 to 200°C± 1%FS±1 digit 200 to 2000°C±0.5%FS±1 digit	
		W40	Thermocouple WRe0-26	*2 0 to 2000°C	1°C	0 to 500°C± 5%FS±1 digit 500 to 2000°C±0.5%FS±1 digit	
		P01	JIS Pt100Ω	0 to 100°C	0.1°C	±0.5%FS±1 digit	
		P02	JIS Pt100Ω	*3 0 to 200°C	0.1°C	±0.5%FS±1 digit	
		P03	JIS Pt100Ω	0 to 300°C	1°C	±0.5%FS±1 digit	
		P05	JIS Pt100Ω	0 to 500°C	1°C	±0.5%FS±1 digit	
		P10	JIS Pt100Ω	0 to 50°C	0.1°C	±0.5%FS±1 digit	
		P34	JIS Pt100Ω	-50 to 50°C	0.1°C	±0.5%FS±1 digit	
		P43	JIS Pt100Ω	-200 to 50°C	0.1°C	±0.5%FS±1 digit	
		P44	JIS Pt100Ω	-200 to 300°C	1°C	±0.5%FS±1 digit	
		P45	JIS Pt100Ω	-100 to 100°C	1°C	±0.5%FS±1 digit	
		N35	Ni508Ω	-50 to 150°C	0.1°C	±0.5%FS±1 digit	
		N39	SSP129B	-45 to 70°C	0.1°C	±0.5%FS±1 digit	
		C01	4 to 20mA linear	0 to 100%	0.1%	±0.5%FS±1 digit	
		C02	4 to 20mA linear	0 to 50%	0.1%	±0.5%FS±1 digit	
		C03	4 to 20mA linear	0 to 100°C	0.1°C	±0.5%FS±1 digit	
		C14	4 to 20mA linear	0 to 14PH	0.1PH	±0.5%FS±1 digit	
		C81	4 to 20mA linear	-20 to 80°C	0.1°C	±0.5%FS±1 digit	
		L51	-5 to 5mV linear	-50 to 50%	0.1%	±0.5%FS±1 digit	
		M01	0 to 10mV linear	0 to 100%	0.1%	±0.5%FS±1 digit	
		V01	1 to 5V linear	0 to 100%	0.1%	±0.5%FS±1 digit	
		V52	1 to 5V linear	0 to 200	0.1	±0.5%FS±1 digit	
		V53	1 to 5V linear	0 to 300	1	±0.5%FS±1 digit	
		V54	1 to 5V linear	0 to 400	1	±0.5%FS±1 digit	
		V55	1 to 5V linear	0 to 500	1	±0.5%FS±1 digit	
		V58	1 to 5V linear	0 to 800	1	±0.5%FS±1 digit	
		V60	1 to 5V linear	0 to 50	0.1	±0.5%FS±1 digit	
V65	1 to 5V linear	0 to 1000	1	±0.5%FS±1 digit			
IV	Power voltage	0	AC100/110V, 200/220V 50-60Hz				
		4	AC120V, 240V 50-60Hz				
V	Additional functions	Specifications				Models to which additional functions are applicable All models	
		00	None				SDC100 0B, 5G
		F0	A fine control potentiometer is provided.				
			Auxiliary output 4 to 20mA	Alarm monitor	Span type	Relay contact SPST	
		R00	Provided	Not provided	—	—	SDC1004Y
		Y0	Not provided	Provided	Wide span type	NO+NO	SDC101, 103
		Y1	Not provided	Provided		NC+NC	SDC101, 103
		P00	Provided	Provided		NO+NO	SDC1014Y
		P01	Provided	Provided		NC+NC	SDC1014Y
		Y2	Not provided	Provided	Narrow span type	NO+NO	SDC101, 103
		Y3	Not provided	Provided		NC+NC	SDC101, 103
		P02	Provided	Provided		NO+NO	SDC1014Y
		P03	Provided	Provided		NC+NC	SDC1014Y
		B00	Down scale, burnout				SDC100, 102
		Q00	Down scale, burnout				Y0 of SDC101,103 or equivalent
		Q01	Down scale, burnout				Y1 of SDC101,103 or equivalent
Q02	Down scale, burnout				Y2 of SDC101,103 or equivalent		
Q03	Down scale, burnout				Y3 of SDC101,103 or equivalent		

\* The maximum indicating range in \*1 and 2 is 1999°C, and that of \*3 is 199.9°C.

## 2. SPECIFICATIONS

### 1. Common Specifications

#### Display

Indication accuracy:  $\pm 0.5\%$  F.S. (For exemption, see model number table)

Digital display: 3 1/2 digits, 7-segment red LED display

\*<sub>1</sub> Digital display contents: SP/PV switch changeover display

\*<sub>2</sub> Bar display: 5-segment red LED and 5-segment green display

\*<sub>3</sub> Bar display contents: Deviation indication 2% F.S. step

to -10	-10 to -8	-8 to -6	-6 to -4	-4 to -2	+2 to +4	+4 to +6	+6 to +8	+8 to +10	+10 to
--------	-----------	----------	----------	----------	----------	----------	----------	-----------	--------

△

Indication contents PV-SP (%FS)

\*<sub>4</sub> Bar display accuracy:  $\pm 1\%$  each

\* None of \*<sub>1</sub>, \*<sub>2</sub>, \*<sub>3</sub>, and \*<sub>4</sub> is applicable when only the indicator is used.

#### Setting Assembly

Setting accuracy:  $\pm 0.5\%$  F.S. See model number table.

#### Setting method

Local type: Setting by LSP setting dial on front panel

SDC100: Hi/Lo monitor is not provided.

SDC101: Hi/Lo monitor is provided.

Remote type: Setting by external setting signal input (A remote/local selector switch is provided.)

SDC102: Hi/Lo monitor is not provided.

SDC103: Hi/Lo monitor is provided.

Input 1 to 5V DC

Bias current  $\pm 0.4\mu\text{A}$

Display accuracy  $\pm 0.25\%$  F.S.  $\pm 1$  digit

PV, RSP signal inputs are not isolated.

Control assembly: See individual specifications.

Additional function: See additional specifications.

Type of PV input: Thermocouple, DC voltage, DC current, resistance thermometer

Allowable signal source resistance:

Thermocouple, DC voltage; Lower than  $250\Omega$

Resistance thermometer; Lower than  $4\Omega$

Input impedance: Current input; Lower than  $10\Omega$

Input bias current: Thermocouple, DC voltage;  $\pm 0.5\mu\text{A}$

Resistance thermometer;  $1\pm 0.5\text{mA}$

Burnout: Up-scale or down-scale

(thermocouple, DC voltage)

Allowable ambient temperature:  $-20$  to  $55^\circ\text{C}$

Storage temperature:  $-20$  to  $60^\circ\text{C}$

Allowable ambient humidity: Lower than 90%RH at  $40^\circ\text{C}$

Rated power voltage: 100/110V or 200/220V AC, 50-60Hz

120V or 240V AC, 50-60Hz

Allowable power voltage fluctuation:

90 to 121V at 100/110V rating

180 to 242V at 200/220V rating

108 to 132V at 120V rating

216 to 264V at 240V rating

Power consumption: 15VA

Insulation resistance: Higher than  $50\text{M}\Omega$  between each terminal and case by using a 50V DC megger

Dielectric strength: 1500V AC, 1 min between power terminals and case

Installation: Indoor panel mounting

Vibration resistance: 0.5G max. (10 to 60Hz, in X, Y, Z directions, 2 hours each)

Shock resistance: 50G max. (3 times)

Painting color: Mask indicator; Brown smoke

Mask setter; Metallic hairline

Instrument frame; Moss green

Munsell 2.5GY3/1

Case; Moss green Munsell 2.5GY3/1

Weight: About 1.5kg

Standard accessories: Mounting bracket 1 set

Part No. N-3130

Optional parts: Dust cover

Part No. 81401330A

Terminal cover Part No. N-3133

## 2. Individual Specifications

Model No.	Control action	Specifications				
4Y	Indicator	Indication range: 0 to 100% F.S.				
0A	ON-OFF (Relay contact output)	<p>Output: Relay contact SPDT</p> <p>Relay contact: 250V AC 30V DC 5A Resistive load 250V AC 30V DC 1A Inductive load (<math>\cos\phi=0.4</math>)</p> <p>Differential gap: 0.2 to 10% F.S. (variable)</p> <p>Output operation:</p> <table border="0"> <tr> <td>Faston Lo side connection SDC100, 102 Terminals ⑧-⑨ are closed and terminals ⑧-⑦ are open when relay turns on (<math>PV &lt; SP</math>)</td> <td>Faston Lo side connection SDC101, 103 Terminals ②-③ are closed and terminals ②-① are open when relay turns on (<math>PV &lt; SP</math>)</td> </tr> <tr> <td>Faston Hi side connection SDC100, 102 Terminals ⑧-⑨ are open and terminals ⑧-⑦ are closed when relay turns off (<math>PV &lt; SP</math>)</td> <td>Faston Hi side connection SDC101, 103 Terminals ②-③ are open and terminals ②-① are closed when relay turns off (<math>PV &lt; SP</math>)</td> </tr> </table> <p>(Faston terminals are connected to Lo side at the delivery time from factory)</p>	Faston Lo side connection SDC100, 102 Terminals ⑧-⑨ are closed and terminals ⑧-⑦ are open when relay turns on ( $PV < SP$ )	Faston Lo side connection SDC101, 103 Terminals ②-③ are closed and terminals ②-① are open when relay turns on ( $PV < SP$ )	Faston Hi side connection SDC100, 102 Terminals ⑧-⑨ are open and terminals ⑧-⑦ are closed when relay turns off ( $PV < SP$ )	Faston Hi side connection SDC101, 103 Terminals ②-③ are open and terminals ②-① are closed when relay turns off ( $PV < SP$ )
Faston Lo side connection SDC100, 102 Terminals ⑧-⑨ are closed and terminals ⑧-⑦ are open when relay turns on ( $PV < SP$ )	Faston Lo side connection SDC101, 103 Terminals ②-③ are closed and terminals ②-① are open when relay turns on ( $PV < SP$ )					
Faston Hi side connection SDC100, 102 Terminals ⑧-⑨ are open and terminals ⑧-⑦ are closed when relay turns off ( $PV < SP$ )	Faston Hi side connection SDC101, 103 Terminals ②-③ are open and terminals ②-① are closed when relay turns off ( $PV < SP$ )					
0B	Time proportional (Relay contact output)	<p>Output: Relay contact SPDT</p> <p>Relay contact: 250V AC 30V DC 5A Resistive load 250V AC 30V DC 1A Inductive load (<math>\cos\phi=0.4</math>)</p> <p>Proportional band: 2 to 5% F.S. (variable)</p> <p>Cycle time: 10 sec to 1 min (variable)</p> <p>Manual reset: <math>\pm 50\%</math> PB</p> <p>Output operation: Terminals ⑧-⑨ are closed and terminals ⑧-⑦ are open when relay turns on (<math>PV &lt; SP</math>).</p>				
6B	Time proportional (Voltage output)	<p>Output: Voltage</p> <p>Output voltage: 24V DC <math>\pm 1.5V</math></p> <p>Internal output resistance: 1.6k<math>\Omega</math></p> <p>Proportional band: 2 to 5% F.S. (variable)</p> <p>Cycle time: 2.5 sec (fixed)</p> <p>Manual reset: <math>\pm 50\%</math> PB</p> <p>Output operation: Output voltage is applied when <math>PV &lt; SP</math>.</p>				
SDC100 SDC101 SDC102 SDC103	Heat time proportional (Relay contact output) + Cool time proportional (Relay contact output)	<p>Output: Relay contact SPDT</p> <p>Relay contact: 250V AC 30V DC 5A Resistive load 250V AC 30V DC 1A Inductive load (<math>\cos\phi=0.4</math>)</p> <p>Proportional band: Heat side; 2% F.S. (fixed) Cool side; 2 to 10% F.S. (variable)</p> <p>Cycle time: Heat side; 25 sec (fixed) Cool side; 10 to 60 sec (variable)</p> <p>Manual reset: <math>\pm 15\%</math> PB (variable)</p> <p>Dead zone: <math>\pm 10\%</math> F.S. (variable)</p> <p>Output operation: Heat side; Terminals ②-③ are closed and terminals ②-① are open when relay turns on (<math>PV &lt; SP</math>). OUT1 Green LED lights. Cool side; Terminals ⑤-⑥ are closed and terminals ⑤-④ are open when relay turns on (<math>PV &lt; SP</math>). OUT2 Red LED lights.</p>				
	3H (Note 1)		<p>(A) When the dead zone is set to (+) side;</p> <p>Heat side proportional band</p> <p>Dead zone</p> <p>Cool side proportional band</p>			
	9H (Note 1)	<p>(B) When the dead zone is set to (-) side;</p> <p>Heat side proportional band</p> <p>Dead zone</p> <p>Cool side proportional band</p>				
	Heat time proportional (Voltage output) + Cool time proportional (Relay contact output)	<p>Output:</p> <p>Heat side; Voltage Output voltage; 24V DC <math>\pm 1.5V</math> Internal output resistance; 1.6k<math>\Omega</math></p> <p>Cool side; Relay contact SPDT Relay contact; 250V AC 30V DC 5A Resistive load 250V AC 30V DC 1A Inductive load (<math>\cos\phi=0.4</math>)</p> <p>Proportional band: Heat side; 2% F.S. (fixed) Cool side; 2 to 10% F.S. (variable)</p> <p>Cycle time: Heat side; 2.5 sec (fixed) Cool side; 10 to 60 sec (variable)</p> <p>Manual reset: <math>\pm 15\%</math> PB (variable)</p> <p>Dead zone: <math>\pm 10\%</math> F.S. (variable)</p> <p>Output operation: Heat side; Voltage is applied between terminals ①+②-when (<math>PV &lt; SP</math>). OUT1 Green LED lights. Cool side; Terminals ⑤-⑥ are closed and terminals ⑤-④ are open when relay turns on (<math>PV &gt; SP</math>). OUT2 Red LED lights.</p>				

SDC100 SDC101 SDC102 SDC103	0D	Time proportional PID (Relay contact output)	<p>Output: Relay contact SPDT</p> <p>Relay contact: 250V AC 30V DC 5A Resistive load 250V AC 30V DC 1A Inductive load (<math>\cos\phi=0.4</math>)</p> <p>Proportional band: 2 to 15% F.S. (variable)</p> <p>Cycle time: 10 sec to 1 min (variable)</p> <p>Reset time: 30 sec to 6 min (variable)</p> <p>Integral control action; Can be turned off. External terminals (M<sub>1</sub>) - (M<sub>2</sub>) are open or internal faston terminals are reconnected to OFF.</p> <p>Rate time: 0 to 3 min (variable)</p> <p>Output operation: Terminals ②-③ are closed and terminals ②-① are open when relay turns on (PV&lt;SP).</p>
	6D	Time proportional PID (Voltage output)	<p>Output: Voltage</p> <p>Output voltage: 24V DC±1.5V</p> <p>Internal output resistance: 1.6kΩ</p> <p>Proportional band: 2 to 15% F.S. (variable)</p> <p>Cycle time: 2.5 sec (fixed)</p> <p>Reset time: 30 sec to 6 min (variable)</p> <p>Integral control action; Can be turned off. External terminals (M<sub>1</sub>) - (M<sub>2</sub>) are open or internal faston terminals are reconnected to OFF.</p> <p>Rate time: 0 to 3 min (variable)</p> <p>Output operation: Output voltage is applied when PV&lt;SP.</p>
	2G	Position proportional PID (Relay contact output)	<p>Output: Modutrol motor driving relay contact</p> <p>Relay contact: 250V AC 30V DC 5A Resistive load 250V AC 30V DC 1A Inductive load (<math>\cos\phi=0.4</math>)</p> <p>Proportional band: 1 to 50% F.S. (variable)</p> <p>Dead zone: 0.2 to 2% F.S. (variable)</p> <p>Reset time: 30 sec to 6 min (variable)</p> <p>Integral control action; Can be turned off. External terminals (M<sub>1</sub>) - (M<sub>2</sub>) are open or internal faston terminals are reconnected to OFF.</p> <p>Rate time: 0 to 6 min (variable)</p> <p>Output operation: When PV&lt;SP, terminals ③-② are closed to operate the motor in the open direction. The green LED lights. When PV&gt;SP, terminals ③-① are closed to operate the motor in the close direction. The red LED lights. When PV=SP, terminals ③-② and ③-① are open to stop the motor operation. Both red and green LEDs go out.</p> <p>Direct/reverse control action: Changeable by changing the connection to the motor.</p> <p>Feedback potentiometer resistance value changeover. Selectable to 100 to 135Ω ⇔ 2kΩ by internal dip switches.</p>
	5G	Continuous PID (Current output)	<p>Output: 4 to 20mA DC</p> <p>Load resistance: Lower than 600Ω</p> <p>Proportional band: 1 to 50% F.S. (variable)</p> <p>Reset time: 20 sec to 6 min (variable)</p> <p>Integral control action; Can be turned off. External terminals (M<sub>1</sub>) - (M<sub>2</sub>) are open or internal faston terminals are reconnected to OFF.</p> <p>Rate time: 0 to 3 min (variable)</p> <p>Output operation: Direct control action reverse control action are selectable. Direct control action; Output current increases when input increases. Reverse control action; Output current decreases when input increases. (The instrument is set to the reverse control action at the delivery time from factory.)</p>

(Note 1) Carefully set SDC101/SDC103 in such a way that three or more relays (including the monitor relay) are not turned on simultaneously.

### 3. Additional Functions

Specifications							Applicable models
No additional functions are provided.							All models
Fine control potentiometer							SDC100, 0B, 5G
Auxiliary output 4 to 20mA	Alarm monitor	Span type	Relay contact SPST	Deviation alarm setting range of controller (%FS)	PV alarm setting range of indicator (%FS)	Differential gap (%FS)	
Provided	Not provided	—	—	—	—	—	SDC1004Y
Not provided	Provided	Wide span type	NO + NO	Hi : SP + 3 to + 50	Hi : 30 to 100	2±1 (fixed)	SDC101, 103
Not provided	Provided		NC + NC				SDC101, 103
Provided	Provided		NO + NO	Lo : SP - 3 to - 50	Lo : 0 to 70		SDC1014Y
Provided	Provided		NC + NC				SDC1014Y
Not provided	Provided	Narrow span type	NO + NO	Hi : SP + 0.3 to + 10	Hi : 30 to 100	0.2±0.1(fixed)	SDC101, 103
Not provided	Provided		NC + NC				SDC101, 103
Provided	Provided		NO + NO	Lo : SP - 0.3 to - 10	Lo : 0 to 70		SDC1014Y
Provided	Provided		NC + NC				SDC1014Y
Monitor setting accuracy	±0.25% FS + indication accuracy of each range under reference condition (See model number table)						
Monitor output	Relay output SPST, Contact rating 250V AC 30V DC 1A resistive load Contact rating 250V AC 30V DC 0.5A inductive load (cosφ=0.4)						
Monitor output operation LED display	Hi, Lo setting (No SP is provided in case of indicator only )						
	Y0,Y2,P00,P02,Q00,Q02						<p>Terminals ⑧-⑦ are closed. Green LED LIGHTS.</p> <p>Terminals ⑧-⑦ are open. No LED is displayed.</p> <p>Terminals ⑧-⑨ are open. No LED is displayed.</p> <p>Terminals ⑧-⑨ are closed. Red LED lights.</p>
	Y1,Y3,P01,P03,Q01,Q03						<p>Terminals ⑧-⑦ are open. Green LED LIGHTS.</p> <p>Terminals ⑧-⑦ are closed. No LED is displayed.</p> <p>Terminals ⑧-⑨ are closed. No LED is displayed.</p> <p>Terminals ⑧-⑨ are open. Red LED lights.</p>

### 3. EXTERNAL DIMENSIONS AND PANEL CUTOUT DIMENSIONS

#### External Dimensions

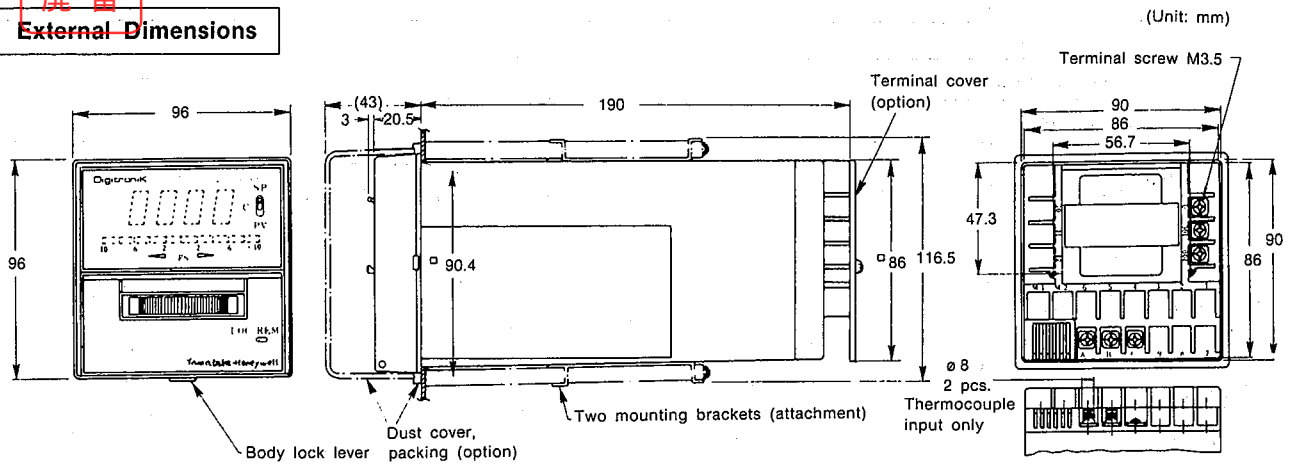
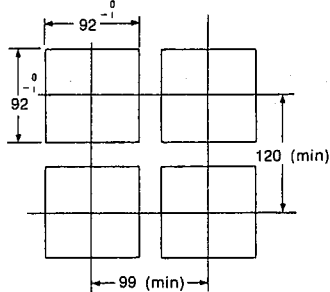

Fig. 1

#### Panel Cutout Dimensions

##### 1. Without Dust Cover



##### 2. With Dust Cover

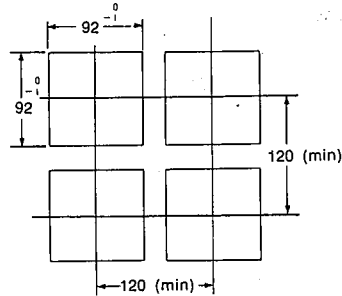

Fig. 2

### 4. INSTALLATION

#### 1. Restriction of Mounting Place

Observe the following conditions when mounting the instrument.

##### (1) Physical Conditions

Allowable ambient temperature: -20 to 55°C  
 Allowable ambient humidity: Lower than 90% RH at 40°C

Vibration resistance: 0.5G max. (10 to 60Hz)

Shock resistance: 50G max.

##### (2) Atmospheric Conditions

1. Don't mount the instrument at a corrosive, explosive, or similar atmosphere.
2. Don't mount the instrument at a place where dust, oil particles, or the like exists. Use a dust cover (Part No. 81401330A) when the instrument is mounted at such a place due to unavoidable circumstances.

##### (3) Electrical Noises

Separate the instrument from a large capacity solenoid switch, a strong high-frequency generating unit, SCR unit, or the like as far as possible.

#### 2. Mounting Method

After mounting the instrument case into the panel cutout, mount two attached mounting brackets to the upper and lower parts of the case, and tighten them securely by turning their screws.

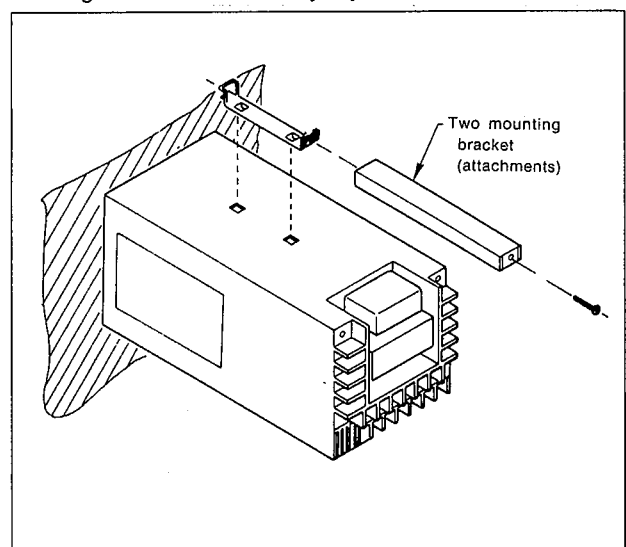

Fig. 3

## 5. CONNECTIONS

廃番

### Cautions on Connections

#### 1. Kinds of Connection Cables

##### (1) For direct thermocouple input

Connect a compensation lead wire (shielded, as required) conforming to the types of thermocouples shown in Table 1 for wiring between the thermocouple and the instrument after confirming the polarities (+)(-).

##### (2) For direct resistance thermometer input

Connect three cables (shielded, as required) having the same diameter between the resistance thermometer and the instrument after confirming (A), (B), (C).

Recommendable cable: JCS364 JKEV-SB or equivalent

##### (3) For standardized input signals

Connect a suitable cable (shielded as required) after confirming polarities (+) (-) for DC current or DC voltage inputs or after confirming (T), (Y), (G) for feedback resistance input of the modutrol motor.

Recommendable cable: JCS364 JKEV-SB or equivalent

##### (4) Grounding of shielded cable

Connect the shielded cable to the panel ground as shown below.

For voltage, current, thermocouple input

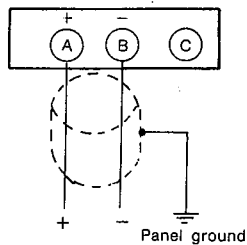

For resistance thermometer input

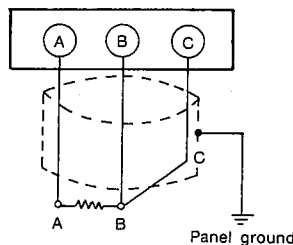

Fig. 4

##### (5) Output signal cable

Connect the DC current, voltage pulse, and other output cable (shielded as required) to the load after confirming polarities (+) (-).

Recommendable cable: JCS364 JKEV-SB or equivalent

#### 2. Input/Output Signal Cables and Power Cable

- (1) Separate the input/output signal cable from the power cable more than 50 cm.
- (2) Don't bundle the input/output signal cable and power cable together.
- (3) Don't pass the input/output signal cable and power cable through the same circuit.
- (4) Separate the input/output signal cable from the power supply, drive source, and load line as far as possible.
- (5) Observe the cautions in (1), (2), (3) and (4) inside the panel, tool.

#### 3. Power Cable Connection

- (1) Use a JIS C3307 600V vinyl insulated cable as power cable.
- (2) Use a line filter, if a surge is noticeably introduced through the power line.

Recommendable line filter:

TOKYO Electrochemical Co. ZAC2205-00

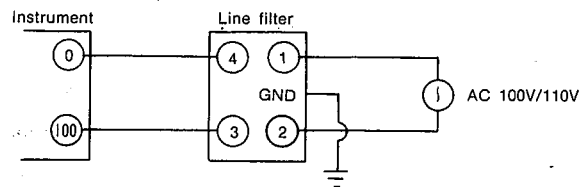

Fig. 5

Mount a CR attenuator or a surge absorber as required for motors and other noise generation sources. A CR attenuator is effective for a surge having a quick rise-time, and a varistor is effective for a pulse surge having a high crest value.

#### 4. Connections

- (1) Use crimp style solderless terminals conforming to terminal screws M3.5.
- (2) No power switch is mounted on the instrument. Mount it outside the instrument separately, if required.
- (3) Connect cables according to the external connection diagram (Fig. 6 and 7).
- (4) After connections, check them without fail, and make sure that connections are correct.

**Table 1 Compensating Lead Wire Specifications**

慶番

Symbols	Old symbols (Reference)	Symbols	Old symbols (Reference)	Divisions according to the uses and tolerances	Working ambient temperature range	Color identification of surface sheath		
<b>JIS C1610-1981</b>								
B	—	BX-G	—	Normal class for general use	0 to 100	Gray		
R	—	RX-G	—	Normal class for general use	0 to 150	Black		
S	—	SX-G		Normal class for heat resistance				
		RX-H						
K	CA	KX-G	WCA-G	Normal class for general use	-20 to 150	Blue		
		KX-GS	WCA-GS	Precision class for general use				
		KX-H	WCA-H	Normal class for heat resistance				
		KX-HS	WCA-HS	Precision class for heat resistance				
		WX-G	WCA-G	Normal class for general use				
		WX-H	WCA-H	Normal class for heat resistance				
		VX-G	WCA-G	Normal class for general use	-20 to 100			
E	CRC	EX-G	WCRC-G	Normal class for general use	-20 to 150	Purple		
		FX-H	WCRC-H	Normal class for heat resistance				
J	IC	JX-G	WIC-G	Normal class for general use		-20 to 150	Yellow	
		JX-H	WIC-H	Normal class for heat resistance				
T	CC	TX-G	WCC-G	Normal class for general use			-20 to 150	Brown
		TX-GS	—	Precision class for general use				
		TX-H	WCC-H	Normal class for heat resistance				
		TX-HS	—	Precision class for heat resistance				
<b>Cables other than JIS</b>								
PR40-20	No exclusive compensating lead wire is available. RX and SX are employable as substitutes, but an error may be produced. See RX and SX.							
WRe0-26								
WRe5-26								



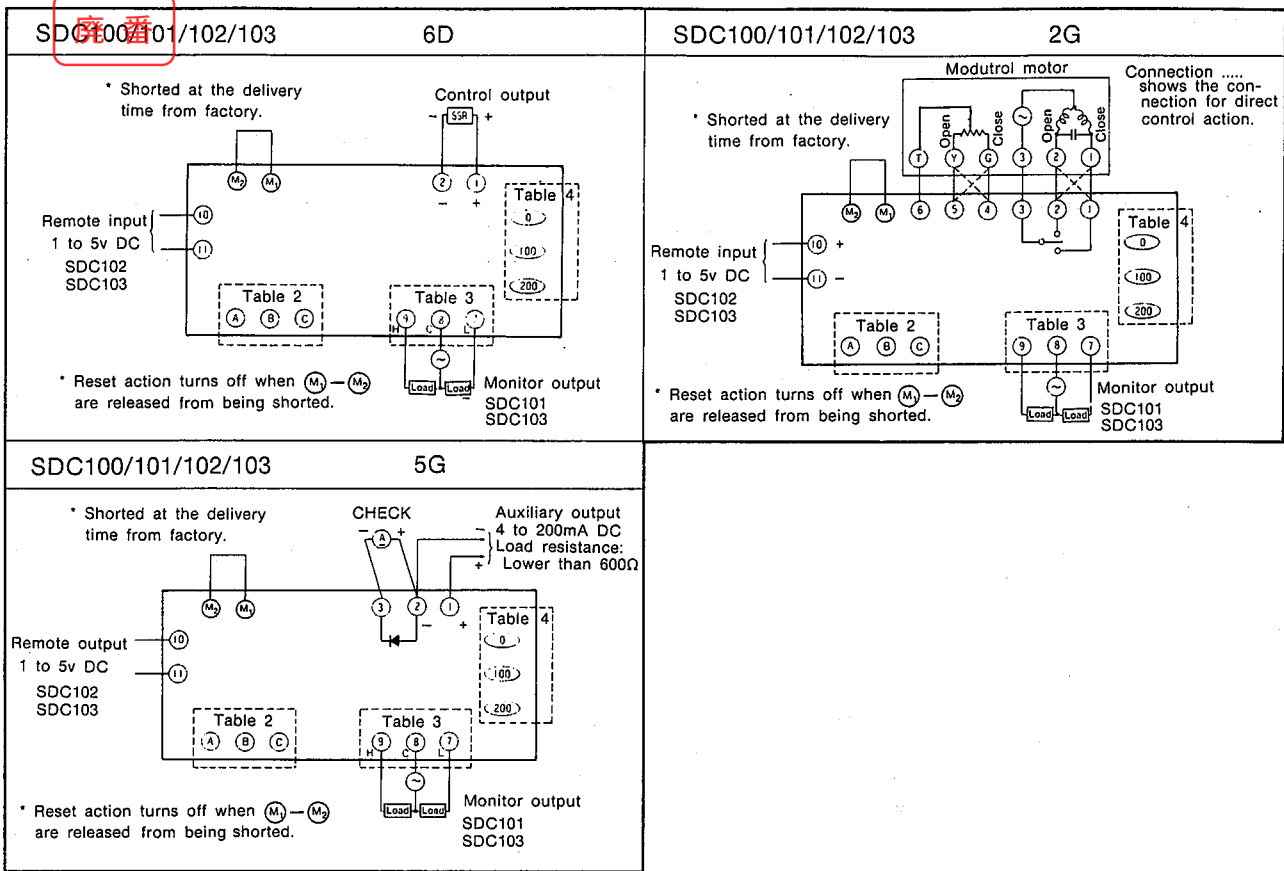

Fig. 7

2. Common Connections

Table 2

Input terminal		
Thermocouple	Resistance thermometer	DC voltage, current

Table 3

Monitor output terminal	
Y0, Y2, P00, P02, Q00, Q02	Y1, Y3, P01, P03, Q01, Q03

Table 4

Power terminals			
Power supply	AC100, 110V, 200, 220V	50 - 60Hz	Power supply
			AC 120, 240V
			50 - 60Hz

## 6 PREPARATION FOR OPERATION

### Control Output Action Change

Draw out the internal unit after turning off the instrument power supply without fail when changing the control output action which is preset at the delivery time.

#### 1. How to Draw Out the Internal Unit

Applicable model numbers		
All model numbers		<p>The internal unit can be drawn out by pulling the mask toward you while pushing up the lock lever mounted at the front lower part of the instrument mask.</p>

#### 2. Changeover of Direct Control Action

Applicable control action number	Reverse control action output is set at the delivery time.	
0A		<p>Faston terminals are mounted on the upper part of the lower PCB on the right side as viewed toward the instrument mask.</p> <p>The reverse control action is switched to the direct control action by reconnecting the faston plug socket from terminal Lo (preset at the delivery time) to Hi.</p> <p>Lo side: Reverse control action Hi side: Direct control action</p>
5G		<p>Faston terminals are mounted at the lower part of the second PCB as counted from the top on the left side as viewed toward the instrument mask.</p> <p>The reverse control action is switched to the direct control action by reconnecting the faston plug socket from terminal R (preset at delivery time) to terminal D.</p> <p>R: Reverse control action D: Direct control action</p>

### 3 変更 (Changeover) of Reset Time (control action) to Off(0)

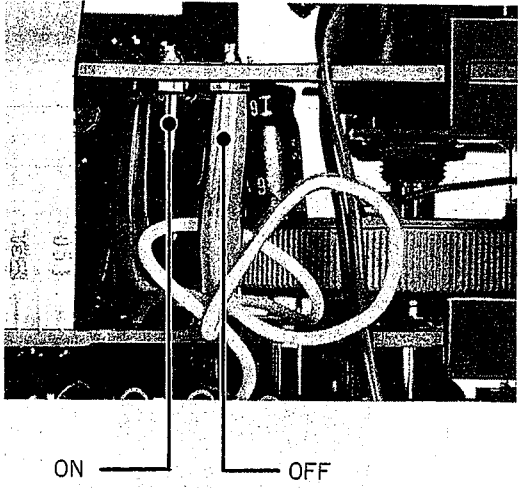
Applicable control action number	20 sec or 30 sec to 6 min (variable) at delivery time	
0D 2D 2G 5G		<p>Select one of two methods.</p> <p>(1) Faston terminals are mounted at the lower part of the second PCB as counted from the top on the left side as viewed toward the instrument mask. The reset time (control action) is turned off(0) by reconnecting the RESET faston plug socket from ON (delivery time) to OFF.</p> <p>(2) The reset time (control action) is turned off by disconnecting the jumper (connected at delivery time) from external terminals (M1)-(M2). (See external connection diagram on pages 9 to 10)</p>

### 4. Changeover of Feedback Potentiometer Resistance Value

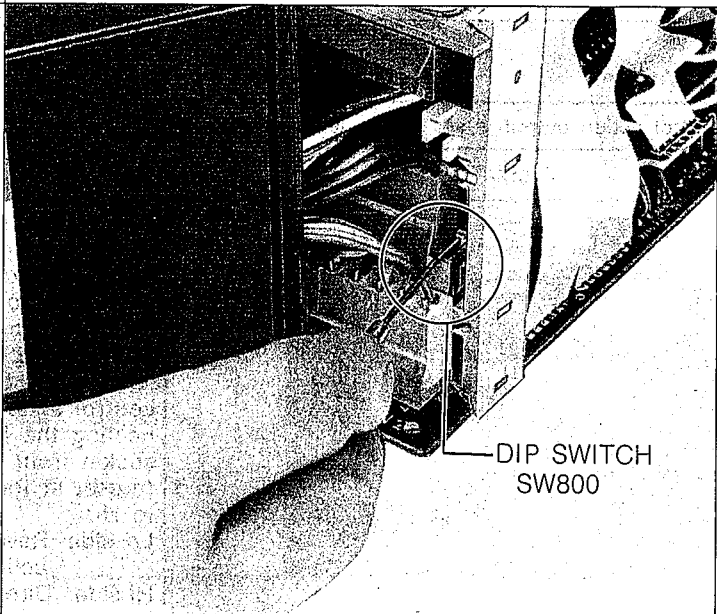
Applicable control action number	135Ω (nominal) at delivery time	
2G		<p>The dip switch (SW800) is mounted at the end of the 3rd PCB as viewed from the top. The resistance value is 135Ω when dip switch (SW800) is turned off, and 2kΩ when dip switch (SW800) is turned on.</p>

# APPEARANCE AND NAMES OF COMPONENTS

## 1. SDC102 0B

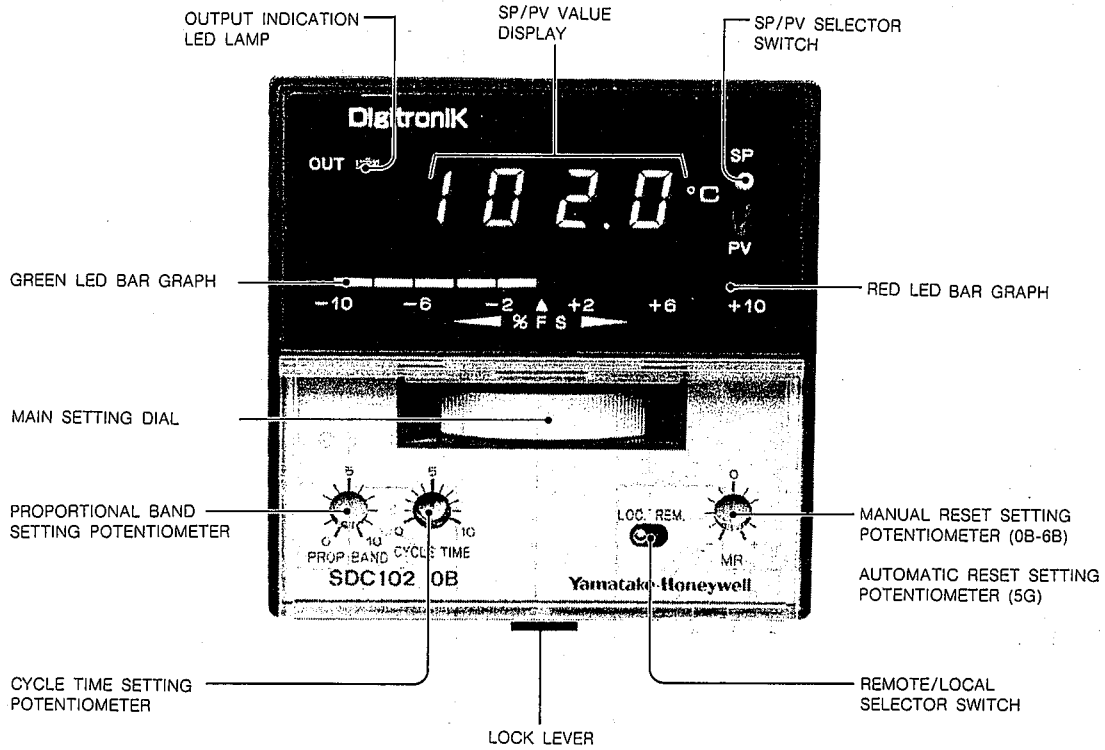

## 2. SDC103 2G

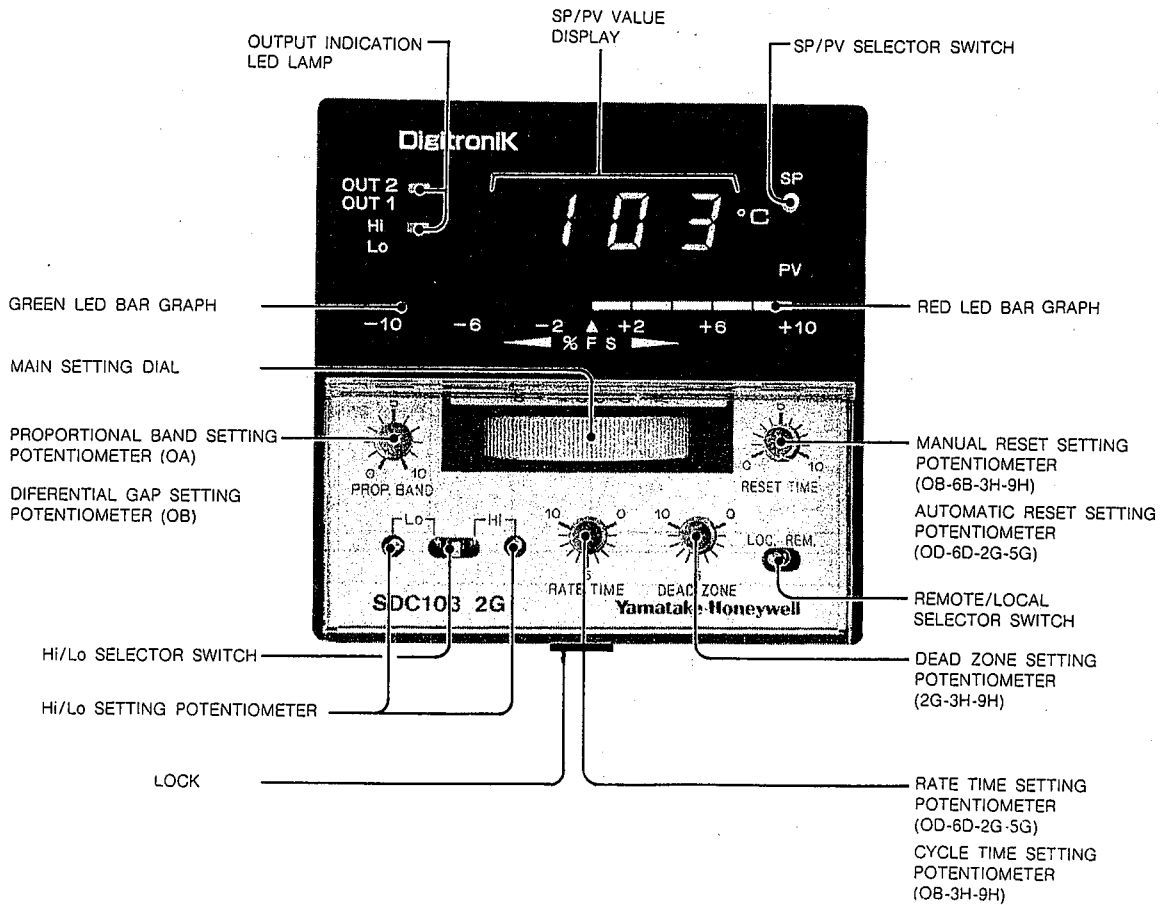

### 3. Mounting Layout of Control Constant Setting Assembly

焼番

#### (1) SDC100-SDC102

SDC100 is not provided with the remote/local selector switch.

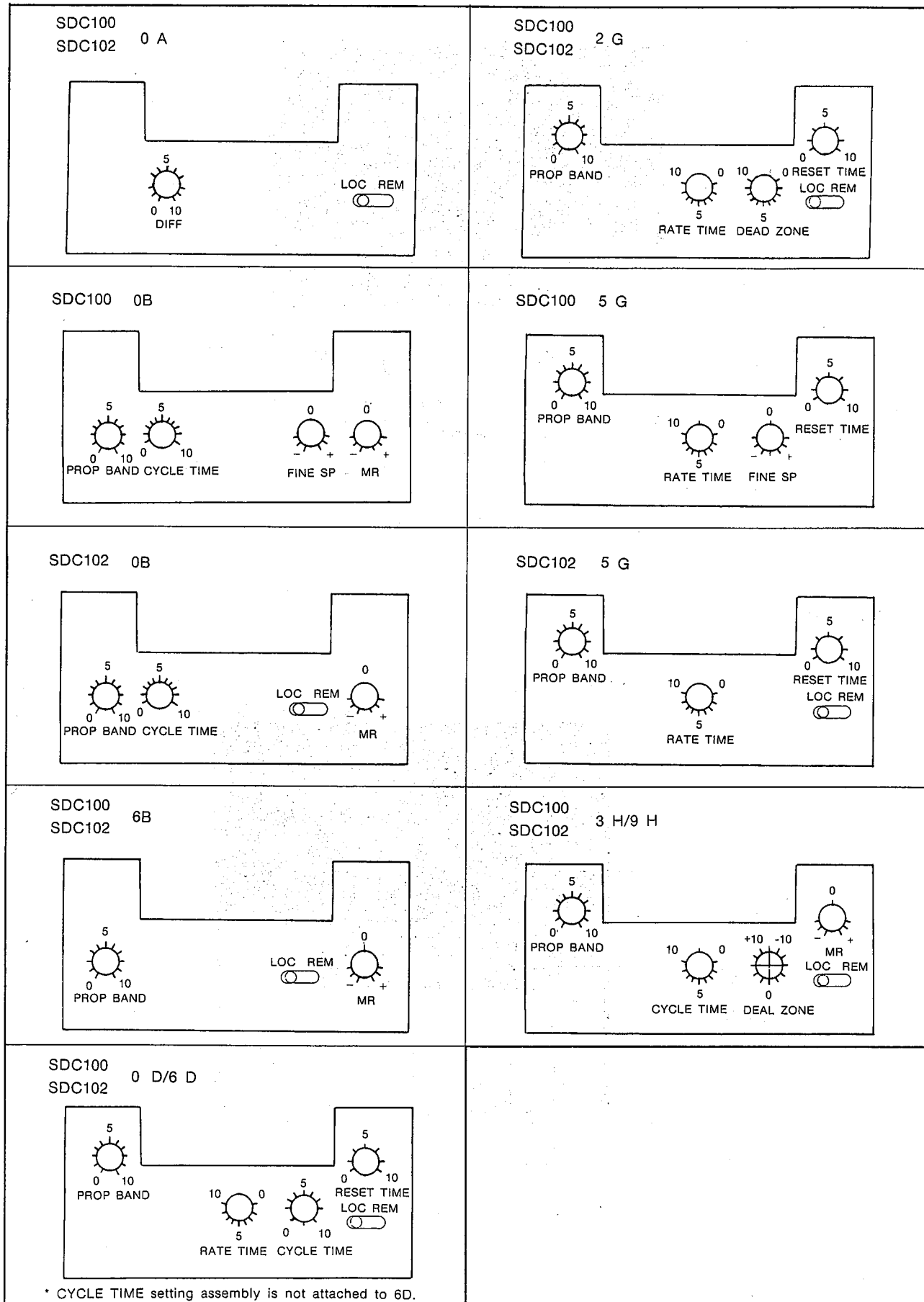
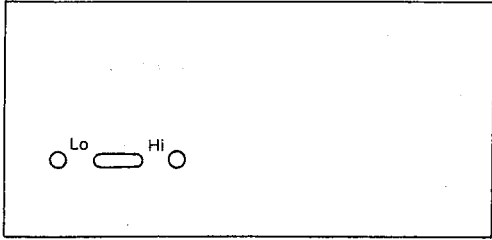

Fig. 8

麿番

SDC101 4Y



SDC101 6B  
SDC103

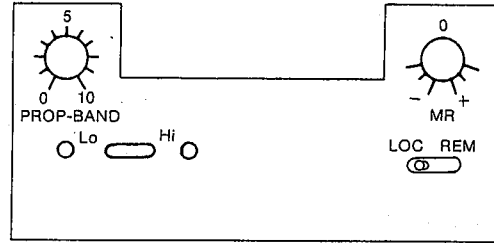

SDC101 0A  
SDC103

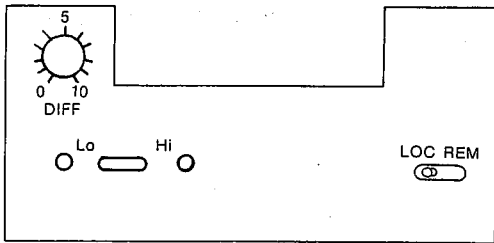

SDC101 0D  
SDC103

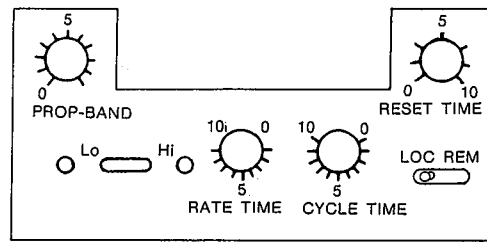

SDC101 0B  
SDC103

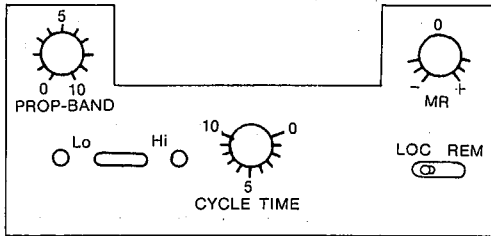

SDC101 6D/5G  
SDC103

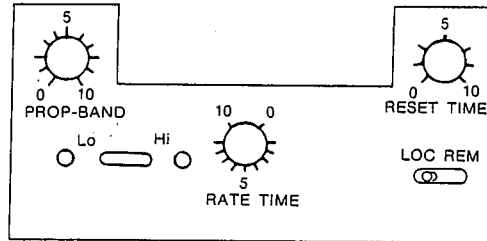

SDC101 2G  
SDC103

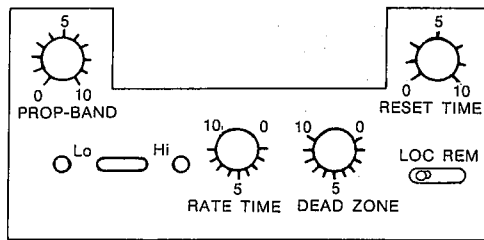

SDC101 3H/9H  
SDC103

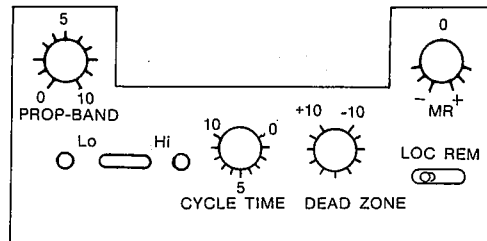

## 8. SETTING AND ADJUSTMENT OF VARIOUS CONTROL CONSTANTS

### 1. Cautions before Setting and Adjustments

- (1) Conform the instrument power voltage before applying it.
- (2) Preheat the instrument for about one hour before operating it under the best condition.
- (3) Setting tools  
Prepare watchman's screwdrivers for setting the control constants.

### 2. Main Setting

#### Main setting of SDC100 · SDC102

- (1) Select the switch lever of SP-PV selector switch to SP.
- (2) Set a set point value by turning the main setting dial, while monitoring the display. When turning the main setting dial clockwise, the set point value increases. When turning the main setting dial counterclockwise, the set point value decreases.
- (3) Fine adjustment of main setting  
The main setting accuracy of the following model can be finely adjusted to be within  $\pm 1^\circ\text{C}$ .

Basic model No.	Control action type No.	Additional type No.	Adjustable range
SDC100	0B	F0	0.1% FS
	5G	F0	

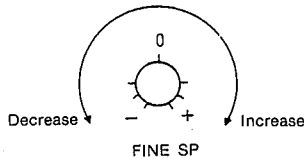



Fig. 9

For fine adjustment, adjust FINE SP potentiometer. The main set point value increases when turning the potentiometer toward (+) from scale 0, and decreases when turning the potentiometer toward (-) from scale 0.

#### Main setting of SDC101 · SDC103

- (1) Set the switch lever of the Hi-Lo selector switch  to the midpoint.
- (2) Set the switch lever of SP-PV selector switch  to SP.
- (3) Set a digital set point value by turning the main setting dial while monitoring the display. The set point value increase when turning the main setting dial clockwise, and decreases when turning the main setting dial counterclockwise.

#### Monitor setting of SDC101 · SDC103

For the setting range of the monitor and output operation, refer to the additional functions on page 5.

- (1) Set the switch lever of Hi-Lo selector switch to Hi or Lo, and turn each potentiometer until the value reaches the displayed monitor set point value.

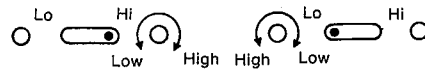

Fig. 10

The set point value becomes high when turning the Hi monitor setting potentiometer clockwise, and it becomes low when turning the Hi monitor setting potentiometer counterclockwise.

The set point value becomes low when turning the Lo monitor setting potentiometer clockwise, and it becomes high when turning the Lo monitor setting potentiometer counterclockwise.

#### Hi-Lo and PV-SP display operation sequence

For the operation sequence, the Hi-Lo selector switch takes precedence of the PV-SP selector switch.

- (1) Set the switch lever of the Hi-Lo selector switch to the midpoint when displaying a PV value or an SP value.
- (2) For displaying Hi or Lo set point value, the Hi-Lo selector switch can be switched directly to Hi or Lo, irrespective of the PV-SP selector switch.
- (3) It is impossible to set both Hi and Lo to turn on simultaneously. Don't set the instrument in such a way as three or more relays including the monitor relay are turned on simultaneously.

### 3. Differential Gap in On-Off Control Action

(1) Relay on-off differential gap in on-off control action

Control action type No.	Differential gap setting range	Setting scale characteristic
0A	0.2 to 10% FS, variable	See Fig. 13
Condition at delivery time	Differential gap is temporarily set to about 5 at the center of the scale.	

#### Setting of Differential gap

Set an optimum value of the differential gap by turning the DIFF potentiometer.

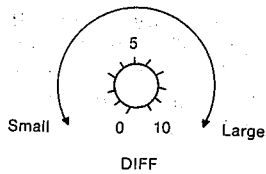

Fig. 11

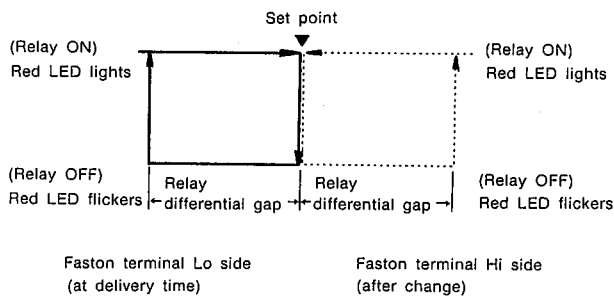

Fig. 12

The differential gap increase when turning the DIFF potentiometer clockwise from 0 to 10 on the scale, or decrease when turning the DIFF potentiometer counterclockwise from 10 to 0 on the scale.

#### Differential Gap Setting Scale Characteristic

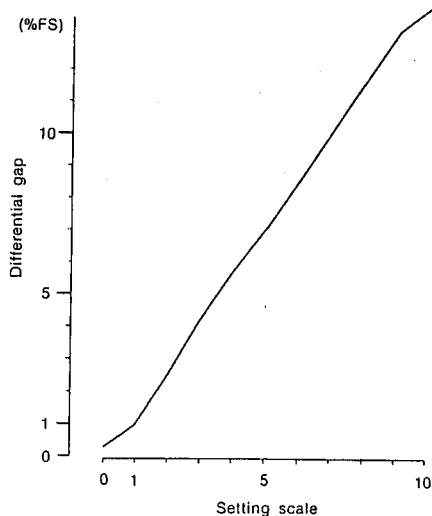

Fig. 13

### 4. Proportional Control Action

(1) Proportional band

Control action type No.	Proportional band setting range	Setting scale characteristic
0B	2 to 5% FS, variable	See Fig. 25 on page 21
6B		See Fig. 27 on page 21
0D	2 to 15% FS, variable	See Fig. 29 on page 22
6D		See Fig. 33 on page 23
2G	1 to 50% FS, variable	See Fig. 36 on page 24
5G		See Fig. 40 on page 25
3H	Heat side: 2% FS, fixed Cool side: 2 to 10% FS, variable	See Fig. 43 on page 26
9H		
Condition at delivery time	Proportional band is temporarily set to about max. 10 on the scale.	

#### Setting of proportional band

Set an optimum value of the proportional band by turning PROP BAND potentiometer.

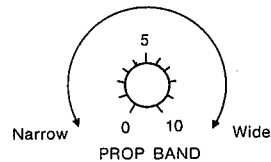

Fig. 14

The proportional band becomes wide when turning the potentiometer toward 10, and it becomes narrow when turning the potentiometer toward 0.

When the proportional band is wide, the control action becomes stable, but the offset increases in general. When the proportional band is narrow, the sensitivity becomes high, the hunting is apt to occur, and the control action becomes unstable.

(2) Cycle time

廃番

Control action type No.	Cycle time setting range	Setting scale characteristic
0B	10 to 60sec variable	See Fig. 26 on page 21
0D		See Fig. 30 on page 22
3H	Heat side: 26sec fixed	—
	Cool side: 10 to 60% sec, variable	See Fig. 44 on page 26
9H	Heat side: 2.5sec fixed	—
	Cool side: 10 to 60% sec, variable	See Fig. 44 on page 26
Condition at delivery time	Cycle time is temporarily set to about 5 at the center of the scale.	

Cycle time setting

Set an optimum value of the cycle time by turning the CYCLE TIME potentiometer.

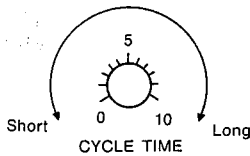

Fig. 15

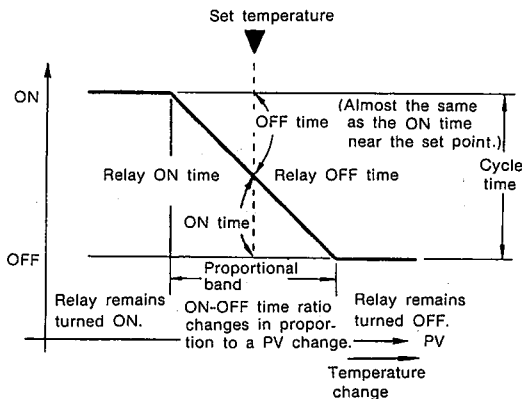

Fig. 16

The cycle time becomes longer as the CYCLE TIME potentiometer is turned clockwise from 0 to 10, and it becomes shorter as the CYCLE TIME potentiometer is turned counterclockwise from 0 to 10.

When the cycle time is short, the on-off operation is repeated frequently, so that the control accuracy is improved in general. In case of the heating operation of heaters, the heater life is proplong, but the lives of the instrument control relays and load-side solenoid switches are shortened. It is, therefore, recommendable to set the cycle time to be longer than 30 seconds as much as possible, if the controlled variable does not fluctuate much in the system.

(3) Manual reset

Control action type No.	Manual reset range	Setting scale characteristic
0B	$\pm 50\%$ PB, variable	—
6B		See Fig. 28 on page 21
3H	$\pm 15\%$ FS, variable	See Fig. 55 on page 26
9H		See Fig. 55 on page 26
Condition at delivery time	Manual reset is temporarily set to about 0 at the scale.	

Manual reset adjustment

Adjust the manual reset by turning the MR potentiometer. Turn the MR potentiometer toward the upper direction, if the offset is produced below the set point; or turn it toward the lower direction, if the offset is produced above the set point.

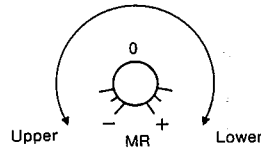

Fig. 17

Example when the offset is produced on the lower side

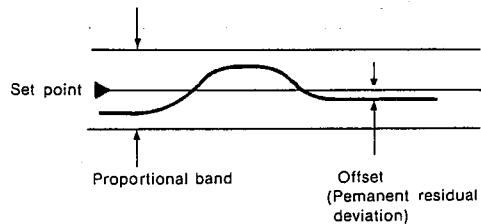

Fig. 18

It takes time until a reset effect appears. Adjust this manual resetting operation carefully.

(4) **Dead zone of position proportional control action**

Control action type No.	Dead zone setting range	Setting scale characteristic
2G	0.2 to 2% FS, variable	See Fig. 39 on page 24
Condition at delivery time	Dead zone is temporarily set to about scale 0.	

**Setting of dead zone**

An optimum value of the dead zone is set by turning the DEAD ZONE potentiometer.



Fig. 19

The dead zone becomes wide when turning the DEAD ZONE potentiometer toward scale 10, and it becomes narrow when turning the DEAD ZONE potentiometer toward scale 0.

Widen the dead zone until hunting stops, if hunting occurs due to unstable action of the modutrol motor near the main set point variable.

Be careful since the control accuracy becomes poor, if the dead zone is too wide.

(5) **Dead zone of heat/cool proportional control action**

Control action type No.	Dead zone setting range	Setting scale characteristic
3H	±10% FS, variable	See Fig. 56 on page 26
9H		See Fig. 56 on page 26
Condition at delivery time	Dead zone is temporarily set to about 0 at the center of the scale.	

**Setting of dead zone**

The dead zone between two-channel control outputs can be set by turning DEAD ZONE potentiometer.

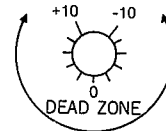

Fig. 20

When DEAD ZONE potentiometer is turned to 0, the control action is set as shown in Fig. 21(A).

When the DEAD ZONE potentiometer is set to (+), the control action becomes as shown in Fig. 21(B).

When the DEAD ZONE potentiometer is set to (-), the control action becomes as shown in Fig. 21(C).

(A) When the DEAD ZONE is set to 0;

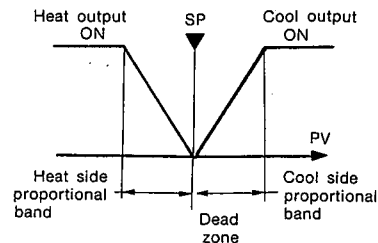

(B) When the DEAD ZONE is set to (+);

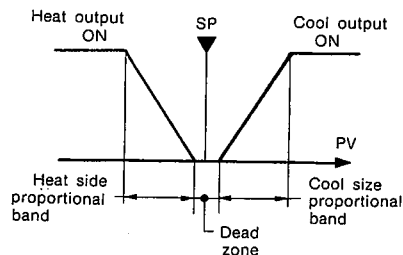

(C) When the DEAD ZONE is set to (-);

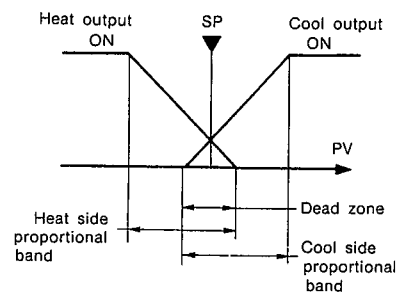

Fig. 21

## 5. Reset Time

戻番

Control action type No.	Manual reset range	Setting scale characteristic
0D	30 sec to 6 min variable	See Fig. 31 on page 22
6D		See Fig. 35 on page 23
2G		See Fig. 37 on page 24
5G	25 sec to 6 min variable	See Fig. 41 on page 25
Condition at delivery time	Reset time is temporarily set to about 0 on the scale.	

### Setting of reset time

Set an optimum value of the reset time by turning the RESET TIME potentiometer.

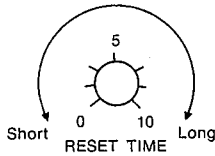

Fig. 22

The reset time becomes long when turning the RESET TIME potentiometer clockwise from 0 to 10, and it becomes short when turning the RESET TIME potentiometer counterclockwise from 10 to 0.

The integral control action becomes stronger as the reset time becomes shorter. Accordingly, if this reset time is too short, the hunting or cycling may occur to cause the control action to be unstable.

Adjust the reset time to an optimum value gradually, while monitoring the control action after setting it to 3 or so first.

## 6. Rate Time

Control action type No.	Rate time reset range	Setting scale characteristic
0D	0 to 3 min variable	See Fig. 32 on page 22
6D		See Fig. 35 on page 23
2G	0 to 6 min variable	See Fig. 38 on page 24
5G	0 to 3 min variable	See Fig. 42 on page 25
Condition at delivery time	Rate time is temporarily set to about 0 on the scale.	

### Setting of rate time

Set an optimum value of the rate time by turning the RATE TIME potentiometer.

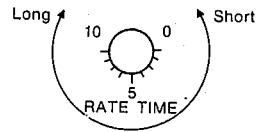

Fig. 23

The rate time becomes long when turning the RATE TIME potentiometer counterclockwise from 0 to 10, and it becomes short when turning the RATE TIME potentiometer clockwise from 10 to 0.

The derivative control action becomes stronger as the rate time becomes longer. Accordingly, if the rate time is too long, a noticeable manipulated variable acts to cause hunting or cycling even when the deviation is small.

Set the RATE TIME to be short first, and then gradually set it to be longer while monitoring the control action.

## 7. Changeover of the Remote/Local Operation Modes

Basic Model numbers SDC102 · SDC103

### (1) Remote operation

The remote operation mode is set by selecting the LOC-REM selector switch from LOC to REM. APV value is indicated when the switch lever of the PV-SP selector switch is set to PV, and a remote set point value is indicated when the PV-SP selector switch is set to SP.

### (2) Local operation

The local operation mode is set when selecting the LOC-REM selector switch from REM to LOC. APV value is indicated when the switch lever of the PV-SP selector switch is set to PV, and a local set point value is indicated when the PV-SP selector switch is set to SP.

(1) Remote operation      (2) Local operation



Fig. 24

9. 番 ATTACHED FIGURES: CONTROL CONSTANT SETTING SCALE CHARACTERISTICS

Attached figure 1 0B type time proportional

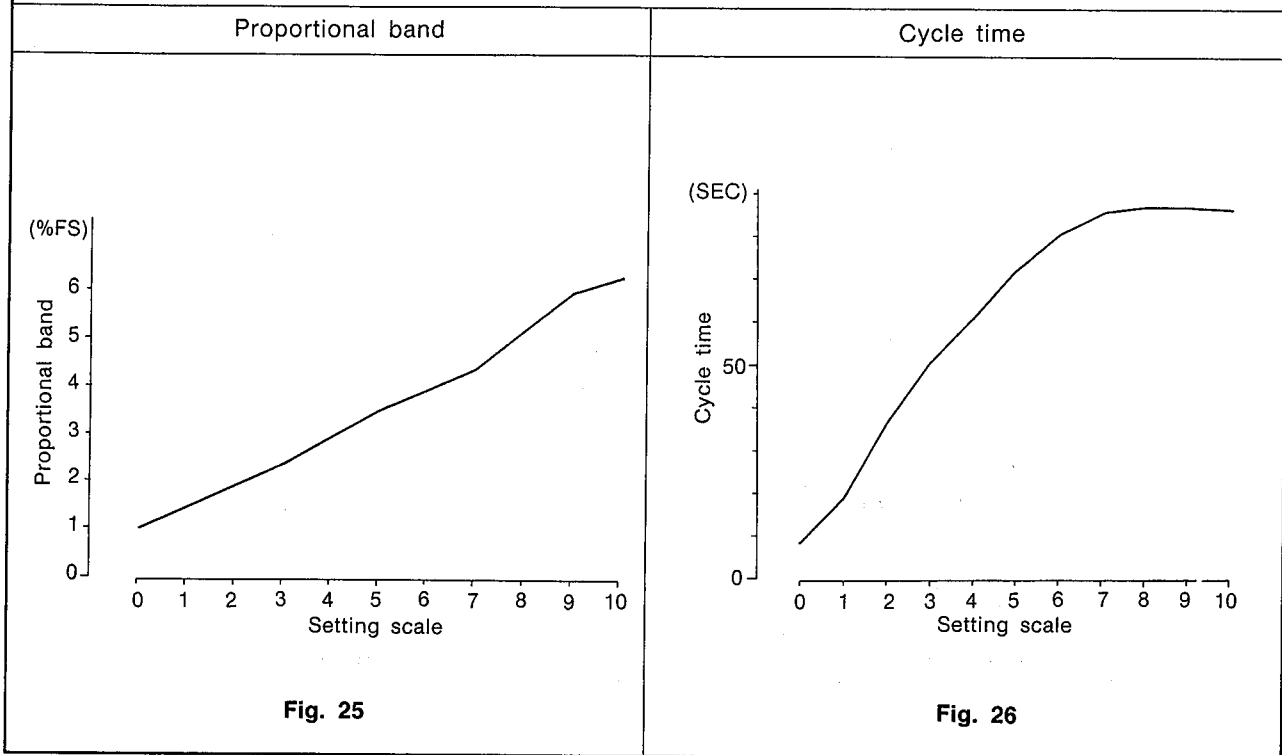

Attached figure 2 6B type time proportional

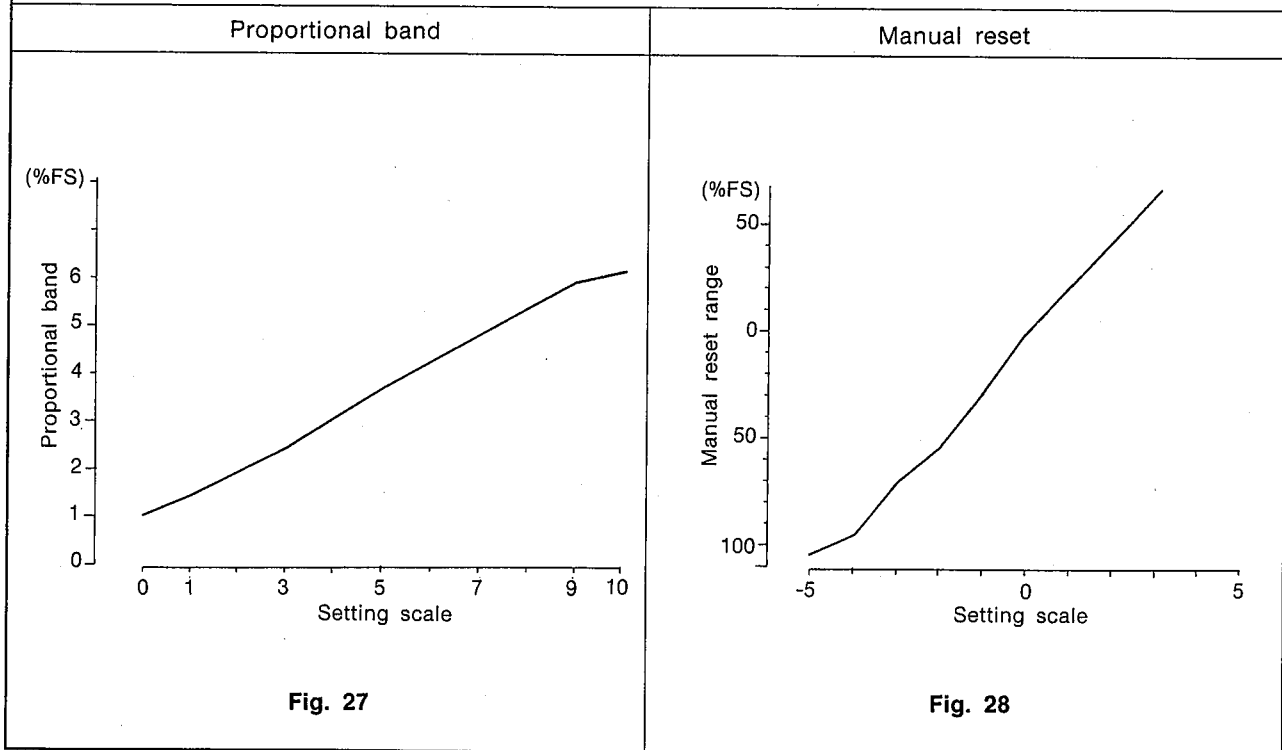

Proportional band

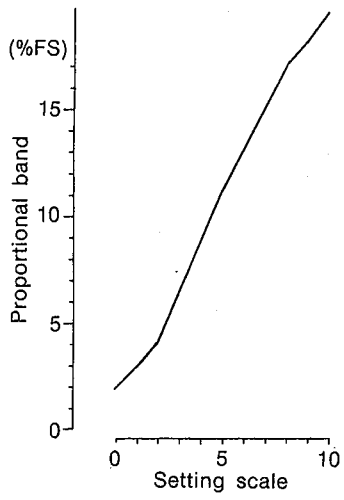

Fig. 29

Cycle time

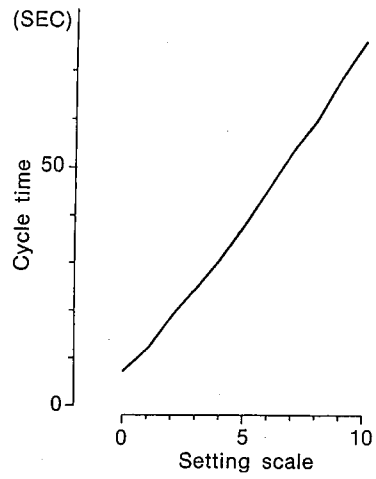

Fig. 30

Reset time

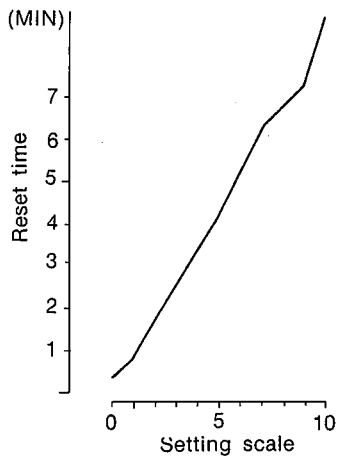

Fig. 31

Rate time

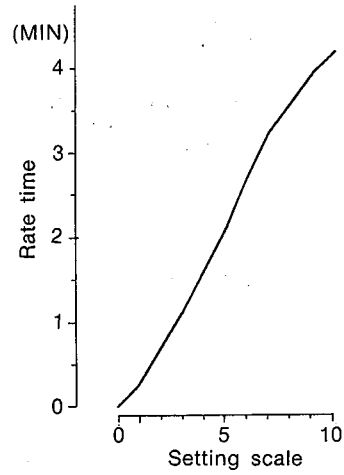

Fig. 32

焼番

Attached figure 4 6D type PID

Proportional band

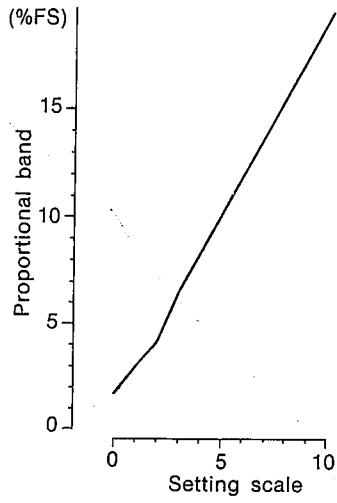

Fig. 33

Reset time

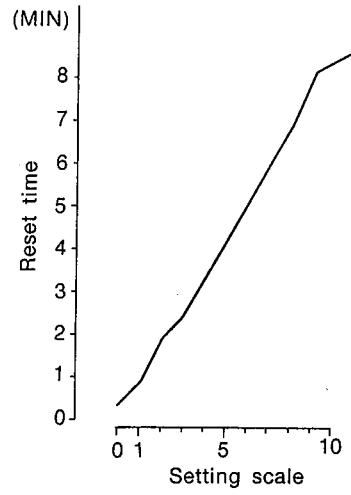

Fig. 34

Rate time

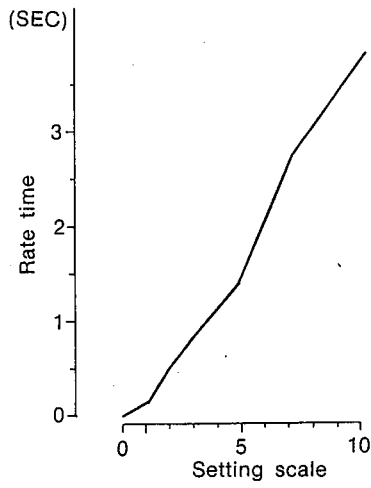

Fig. 35

Proportional band

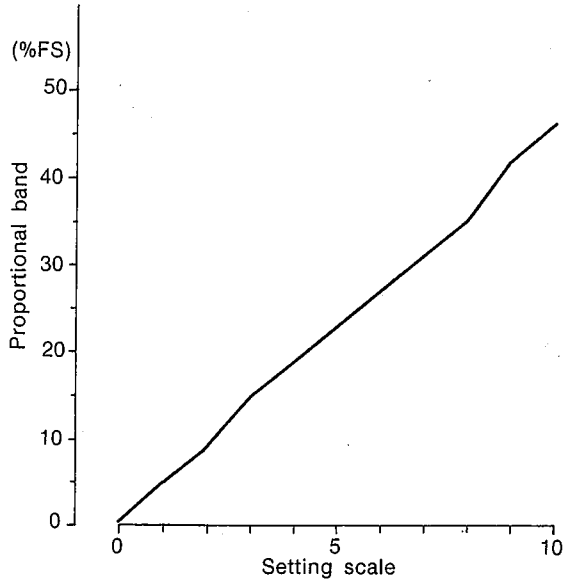

Fig. 36

Reset time

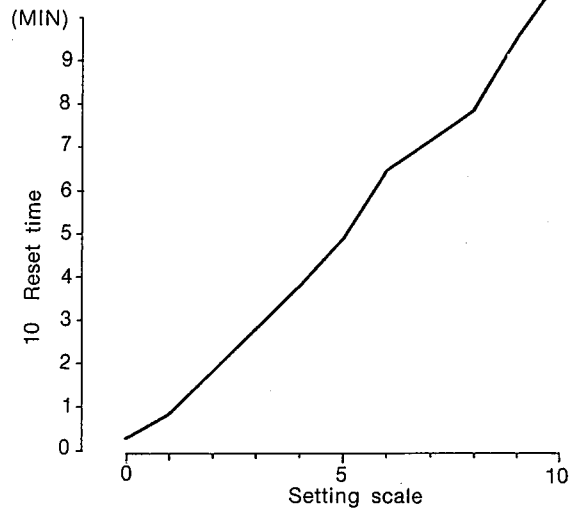

Fig. 37

Rate time

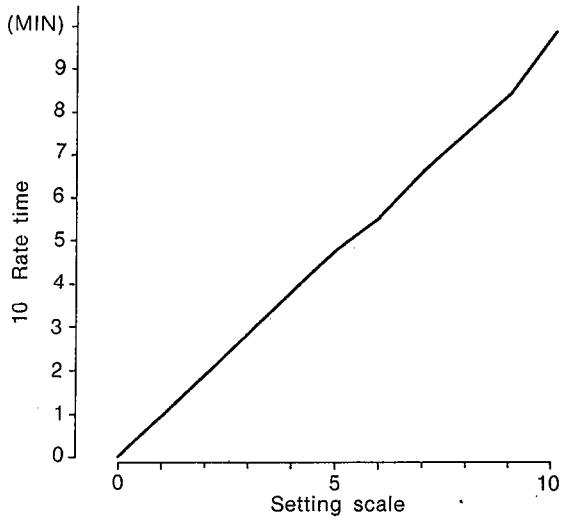

Fig. 38

Dead zone

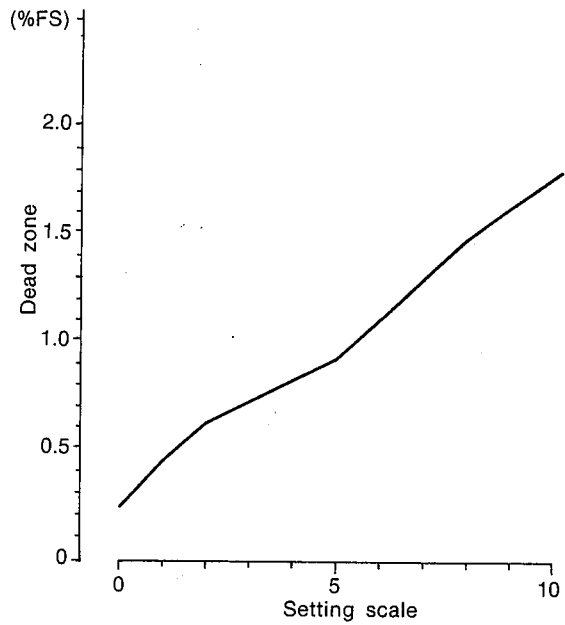

Fig. 39

Proportional band

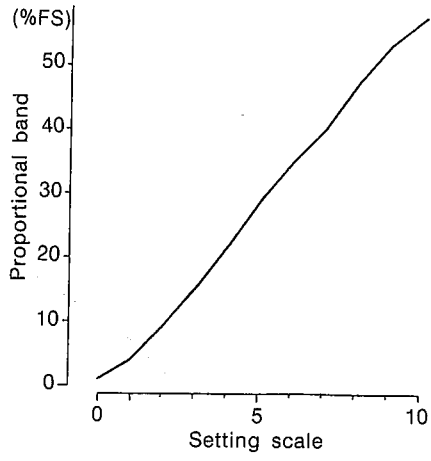

Fig. 40

Reset time

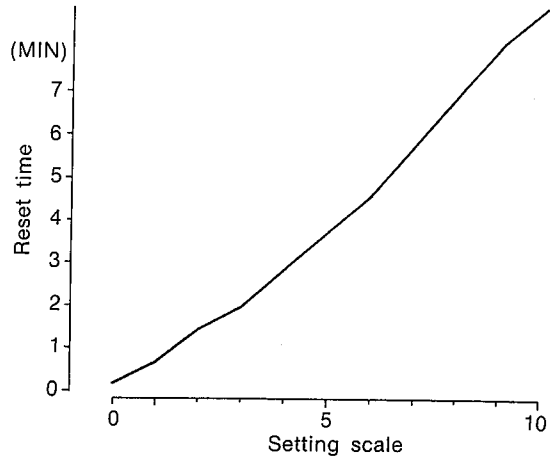

Fig. 41

Rate time

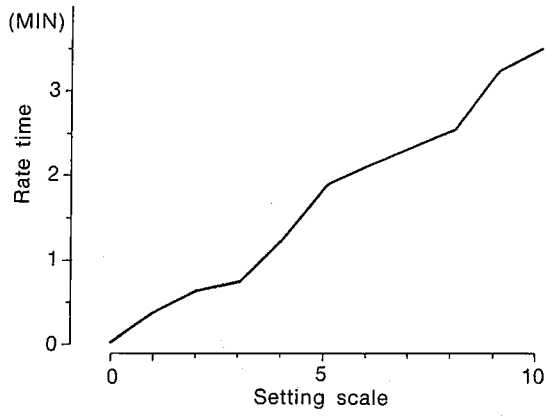

Fig. 42

Cool side proportional band

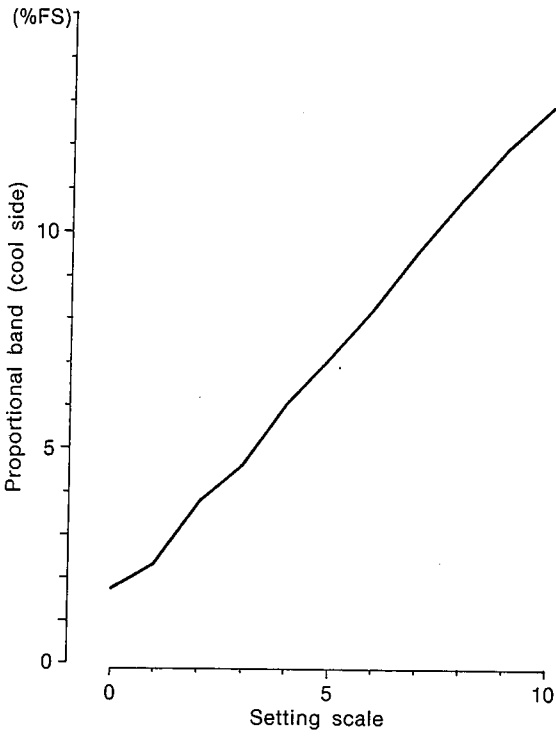

Fig. 43

Cool side cycle time

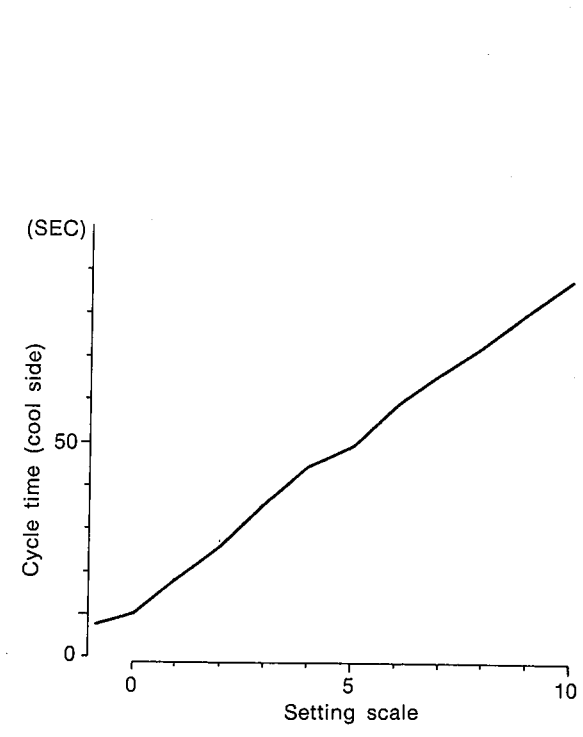

Fig. 44

Manual reset

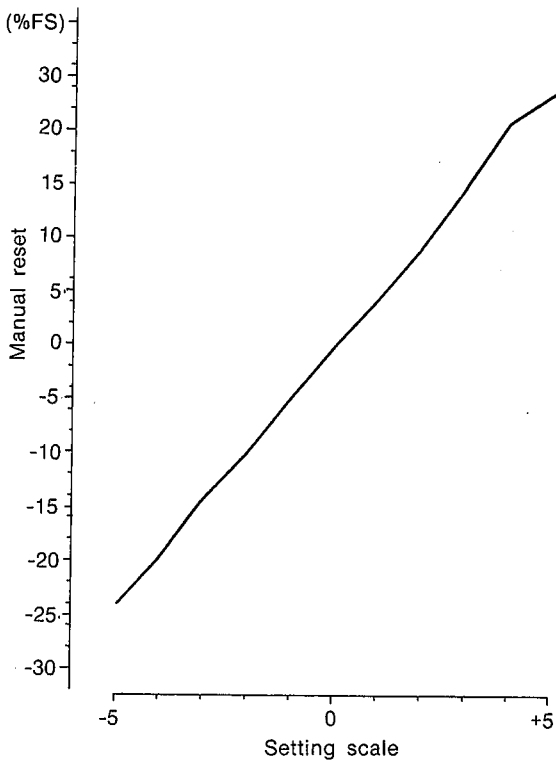

Fig. 45

Dead zone

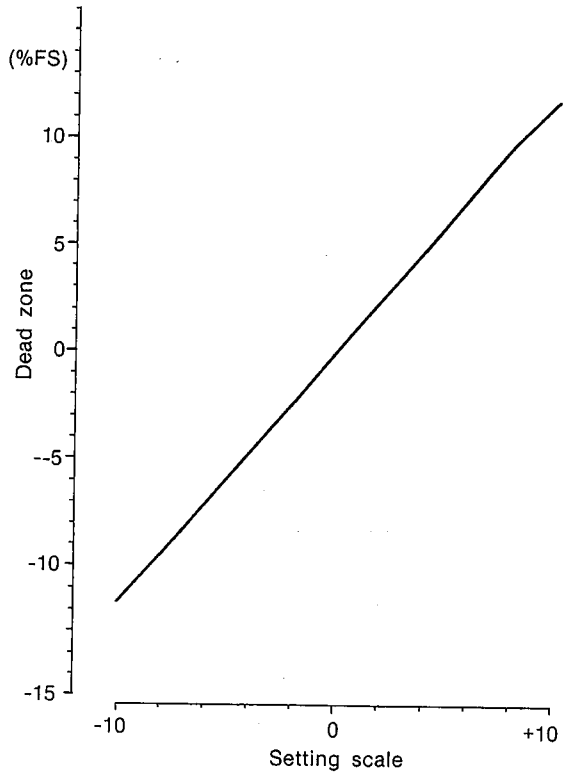

Fig. 46

# 10 MAINTENANCE AND CHECK

## 1. Normal Operation Conditions

Neither green LED bar graph nor red LED bar graph lights when the instrument control action is normal. A process value is controlled near the set point.

One segment of the LED bar graph shows a stepwise indication of 2% FS. Accordingly, if the green or red bar graph lights, it shows that the process value is deviated from the set point more than  $\pm 2\%$  FS. For checking actual process values, select the switch lever of the SP-PV selector switch to PV.

### (1) Trouble during trial run

Symptoms	Possible causes and check points
PV value or SP value is not displayed.	<ul style="list-style-type: none"> <li>Power voltage is abnormal.</li> <li>Check power connection terminal and power voltage.</li> </ul>
Green LED bar graph lights, and PV indicating value overshoots the lower limit of the range.	<ul style="list-style-type: none"> <li>Sensor is not properly connected, or input line is shorted.</li> <li>Check the sensor connection or sensor. Note (4)</li> </ul>
Red LED bar graph lights, and PV indicating value overshoots the higher limit of the range.	<ul style="list-style-type: none"> <li>Sensor is broken.</li> <li>Check the sensor. Replace it, if broken. Note (1)</li> </ul>
Green LED bar graph lights, but PV indicating value does not increase.	<ul style="list-style-type: none"> <li>External load circuit is not connected properly or a contact of output terminals is poor.</li> <li>Check the output terminals and external load circuit for normal connections.</li> </ul>
Control action is reversed in remote input.	<ul style="list-style-type: none"> <li>Remote input is connected reversely.</li> <li>Check the remote input connections.</li> </ul>

Note (4)

#### For resistance thermometer input;

Disconnect cables of the resistance thermometer from instrument input terminals (A), (B), (C), and measure the resistance value between each terminal of the resistance thermometer by using a circuit tester or the like. (See the following table)

#### For thermocouple input;

Short the instrument input terminals (+) (-), and set the setting temperature to room temperature. If the indicating PV value shows the room temperature (temperature at the instrument connection terminals in the strict sense of the word) and the control action is correct with the green bar graph lit, the thermocouple is broken. Replace the thermocouple.

Resistance thermometer	Terminals (A)-(B)	Terminals (B)-(C)
Normal	Resistance value is about 105 to 110 $\Omega$ with JIS Pt100 $\Omega$ and about 540 to 570 $\Omega$ with Ni resistance thermometer (when the detection temperature is about room temperature).	Shorted condition (about 0 $\Omega$ )
Replace	No continuity is detected. (Resistance value is infinite.)	No continuity is detected. (Resistance value is infinite.)
	Shorted (about 0 $\Omega$ )	

**Trouble during operation**

Symptoms	Check points
Green LED bar graph lights, but PV value does not increase.	<ul style="list-style-type: none"> <li>● Check the relay contacts for a poor contact.</li> <li>● Check if thermocouple is broken. Note (1)</li> </ul>
Red LED bar graph lights, but PV value exceeds SP value and increases steadily.	Check the relay contacts for deposit.
Modutrol motor turns on and off repeatedly and cyclically.	<ul style="list-style-type: none"> <li>● Check if the proportional band is too narrow. Widen the proportional band, if so.</li> <li>● Check the connection between instrument and modutrol motor for normal conditions.</li> </ul>
When PV value is equal to SP value, modutrol motor is fully open, and the proportional control action functions only when the PV value is higher than the SP value.	Check the connection between instrument and modutrol motor. Note (5)
When PV value is equal to SP value, modutrol motor is fully closed, and the proportional control action functions only when the PV value is lower than the SP value.	Check the connection between instrument and modutrol motor (at terminals (T) and (G), in particular).
Modutrol motor is fully closed, irrespective of PV values.	Check the feedback potentiometer of modutrol motor. Note (5)

Note (5)

**Modutrol motor connection check**

Check the control action after reconnecting terminals (Y) and (G) of the modutrol motor. Reconnect the cables between the instrument and the modutrol motor, if the modutrol motor cycling stops and the control action is done correctly by reconnecting the terminals (Y) and (G).

Reconnect terminals (Y)-(G) and also terminals (1)-(2) of the modutrol motor again, if the modutrol motor cycling stop. However the modutrol motor action is set to the reverse action (the modutrol motor functions toward the close direction due to the control temperature drop in heating control, and it functions toward the open direction due to the control temperature drop in cooling control.) as a result of reconnecting the modutrol motor terminals (Y) and (G).

Note (6)

**Feedback potentiometer check**

After disconnecting cables from modutrol motor terminals (T), (Y), (G), measure the resistance value between terminals (T)-(Y) or (T)-(G) by using a circuit tester. The modutrol motor is normal if the resistance value ranges from several ohms to about 150Ω or 2kΩ (depending upon the motor rotating angle). If the resistance value is abnormally high, or if no continuity is detected (the resistance value is infinite), replace or clean the potentiometer according to the instruction manual for modutrol motor.

Please contact your nearest Yamatake-Honeywell's sales representative, if a defective point (even if the sensor and external load circuit were found to be normal) cannot be detected by the above check.

廃番

*Specifications are subject to change without notice.*

**Yamatake-Honeywell Co. Ltd.**

Control Products Division  
Totate International Bldg.  
2-12-19, Shibuya, Shibuya-ku  
Tokyo, 150, Japan  
Phone: 81-3-3486-2465  
Cable: YAMATAKECO  
Telex: J22920  
Fax: 81-3-3486-2402

**Yamatake-Honeywell**

**Savemation**

*Helping You Control Your World*

Printed in Japan. (H)