

TDC 3000 SSC II

Programmable Controller

Model KAM 111/211

Introduction

The TDC 3000 Single Strategy Controller II (SSC II) is a high-performance microprocessor-based controller. A compact instrument with PID control and various auxiliary functions, it provides loop control in single-loop units.

Features

- Multiple inputs, outputs and computational functions.
- High-precision operational control functions.
- Self-tuning functions.
- Parameter scheduling functions.
- Self-diagnostic functions.
- Auto-balance function.
- Standardized input processing functions (temperature/pressure compensation, square-root extraction, linearization and filtering).

Operation

- Simultaneous bar graph (in color LCD) and digital value displays.
- User-defined key function.
- Parameter/reference display changes easily made on the side of the instrument.

Engineering support tool

- Easy configuration and simulation through interaction with personal computer.
- Configuration data changes in the field done with dedicated SSC II Handy Communicator.

Standards met

- Panel dimensions comply with IEC regulations.

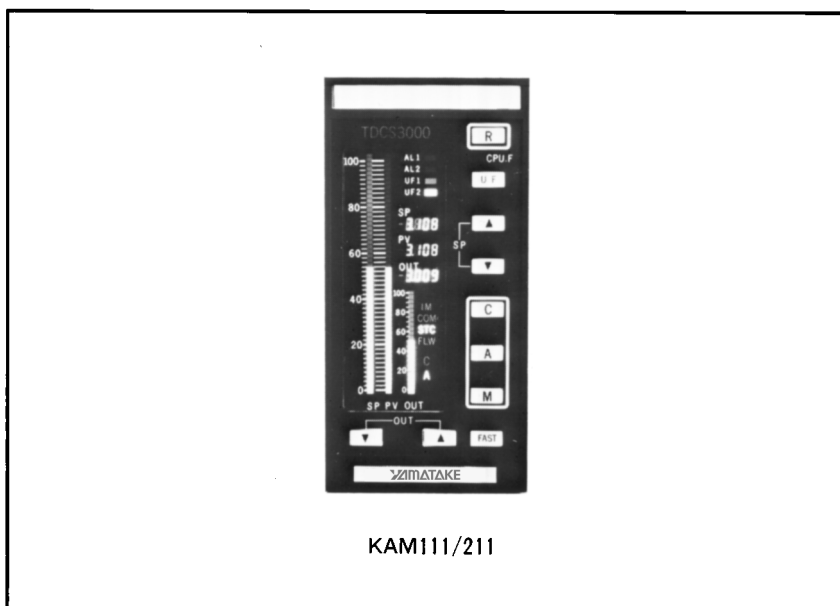

Engineering configuration diagram

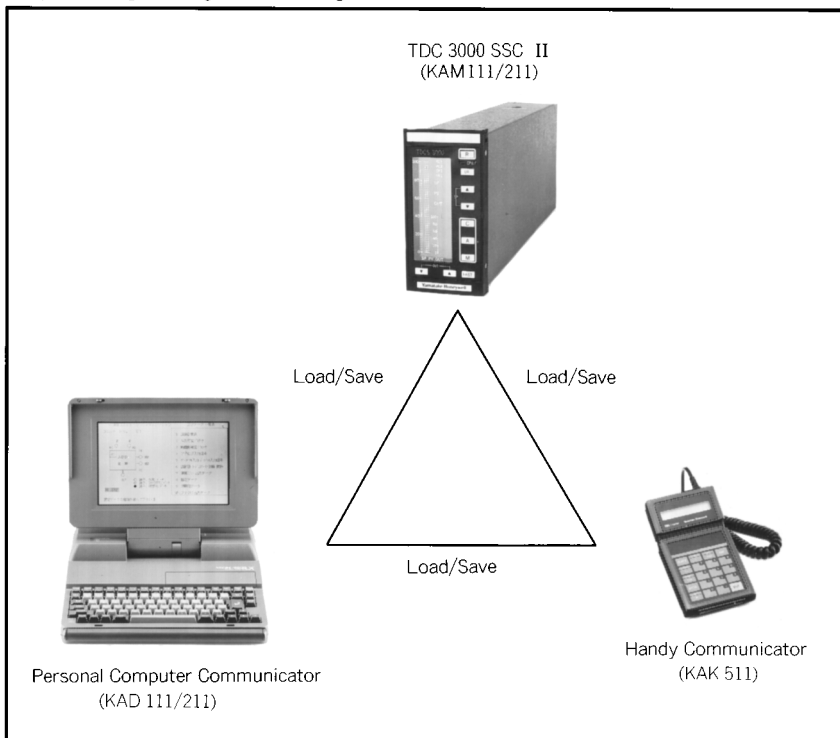

Functional structure

The Programmable Controller has 50 computational units and 94 algorithms. By assigning appropriate algorithms to respective computational units and connecting them as required the user can realize advanced control functions.

Number of computational units : 50
 Number of algorithms : 94
 Variable parameters : %..... 40
 Time 10
 Flag 10

Fixed parameters : Unlimited number
 Linearization table : 6
 (6 tables connectable)
 %→% table..... 4
 %→Time table..... 4
 1 table..... 11 segments

Functions of the Programmable Controller are defined by inputting the following configuration data.

Basic data :

Selects type of control, scan frequency, and other basic items of Programmable Controller operation.

Input processing data :

Selects input processing functions.

Computational unit data :

Selects algorithms to be used and connections of computational units.

Characterizing data :

Data of linearization table (data on segments).

PID computation data :

Selects data on control parameters for PID algorithms.

Output processing data :

Selects data to dictate output signals.

PS parameter :

Selects table number used in parameter scheduling, and selects rate of change limit.

Engineering quantity parameter :

Selects upper, lower limit used in DDM unit, and selects decimal point position.

Functional block diagram

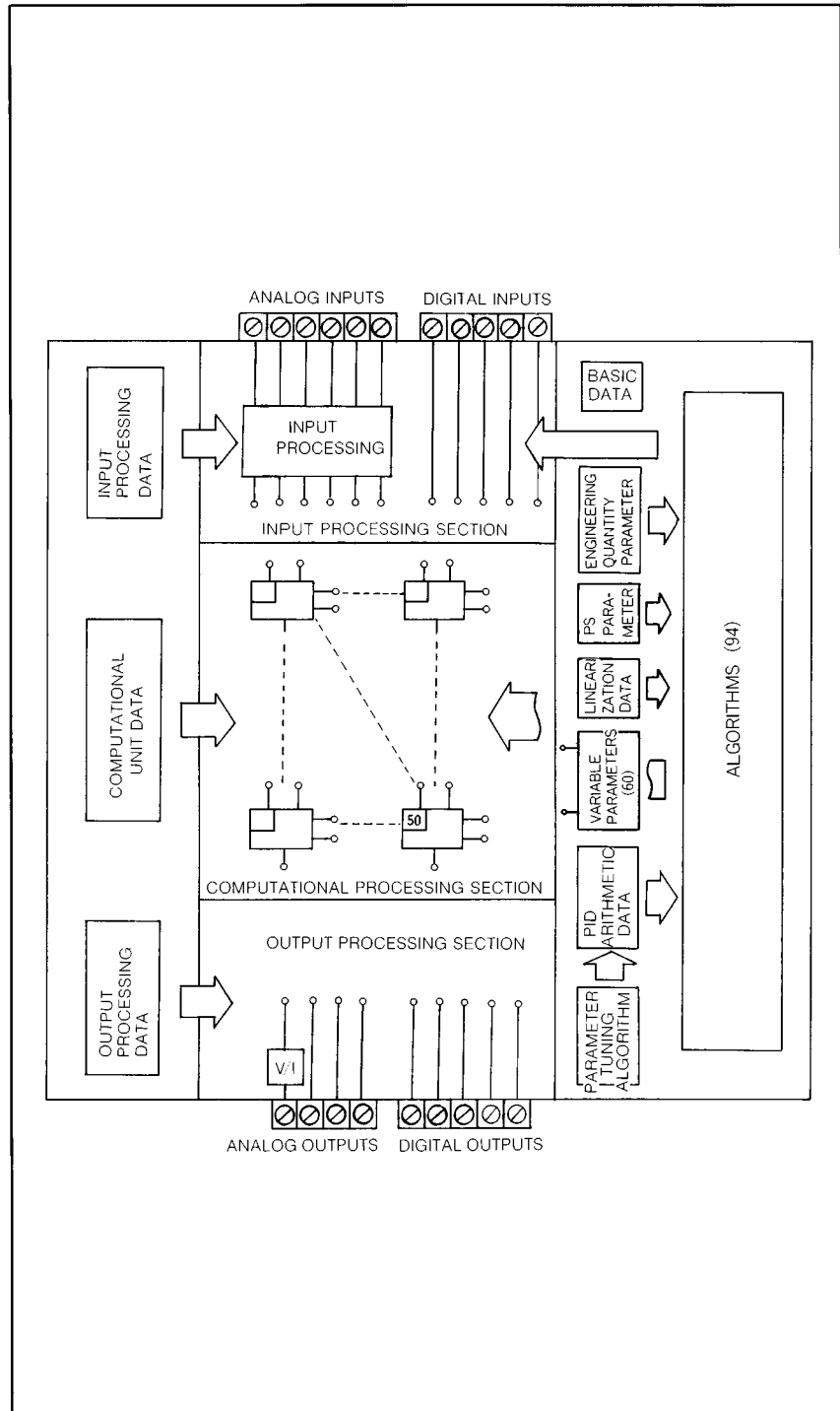

Input processing functions

The Programmable Controller is capable of accepting and processing six analog inputs as illustrated. They are as follows :

- Approximation by linearization table
- Temperature compensation
- Pressure compensation
(Non-SI units (kgf/cm² etc.) and SI units (Pa: Pascal) are available.)
- Square-root extraction
- Digital filtering
- Input alarm detection

Self-tuning function

This function is based on Yamatake Honeywell's unique "Advanced Loop Tuning" method. Since tuning is continuously performed with a closed loop, there is no process instability.

- Automatic tuning by monitoring the process.
- Tuning as requested by the operator.
- Selectable : fixed or cascade control

Parameter scheduling function

This function realizes optimum controllability for a wide range of load change by automatically transferring PID parameters.

This function is applicable for predicted process characteristics due to load or control quantity change in non-linear process.

Input processing functions

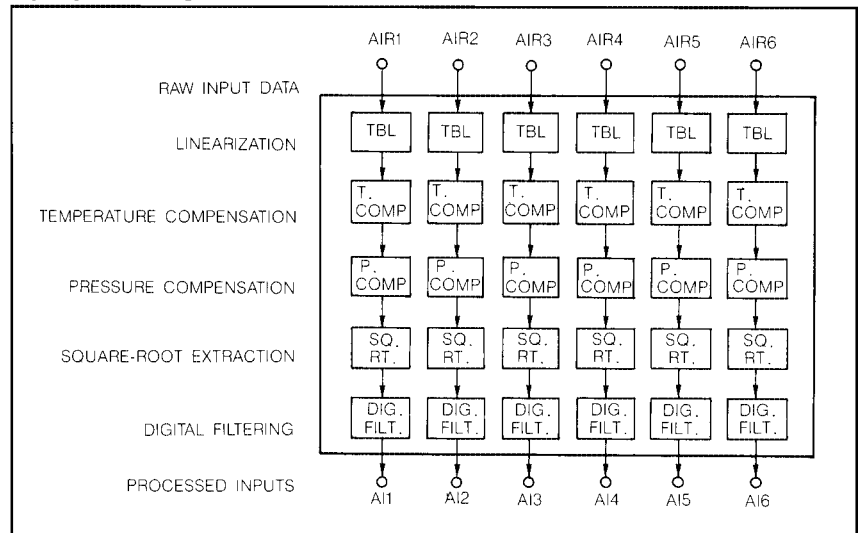

Advanced loop tuning block diagram

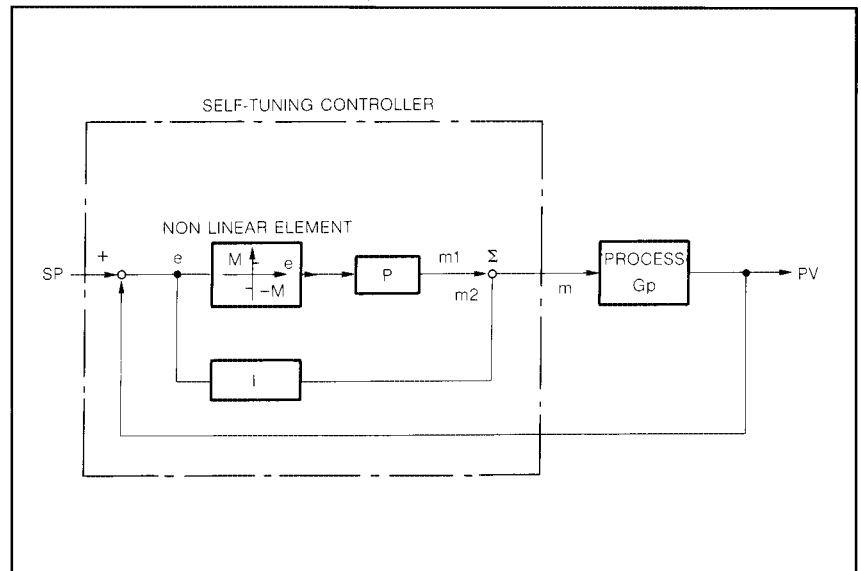

Algorithms

No.	Algorithms		Description	No.	Algorithms		Description
	Name	Symbol			Name	Symbol	
1	Addition	ADD	$OUT=P1*H1+P2*H2$	50	Reverse Linearization Table # 5	TBR5	Reverse function of Linearization table #5.
2	Subtraction	SUB	$OUT=P1*H1-P2*H2$	51	Reverse Linearization Table # 6	TBR6	Reverse function of Linearization table #6.
3	Multiplication	MUL	$OUT=H1*H2$	52	SP Indication Switching	SPSW	SP Indication switching unit
4	Division	DVD	$OUT=H1/H2+P1$	53	PV Indication Switching	PVSW	PV Indication switching unit
5	Absolute Value	ABS	$OUT= H1 $	54	OUT Indication Switching	OUTSW	OUT Indication switching unit
6	Square-Root Extraction	SQR	$OUT=\sqrt{H1}$	55	Mode Switching* ¹ (edge detection)	MODX	Switching M/A/C/F mode
7	Maximum Value	MAX	$OUT=MAX(H1,H2,P1,P2)$	56	—	—	—
8	Minimum Value	MIN	$OUT=MIN(H1,H2,P1,P2)$	57	—	—	—
9	4-point Addition	SGM	$OUT=H1+H2+P1+P2$	58	Alarm Lamp Output # 1	AL1	Alarm lamp output control unit #1
10	High Selector	HSE	$OUT=HI\ Select(H1,H2)$	59	Alarm Lamp Output # 2	AL2	Alarm lamp output control unit #2
11	Low Limiter	LLM	Limiting at low limit value(H2)	60	User Lamp Output # 1	UF1	User lamp output control unit #1
12	Low Selector	LSE	$OUT=LO\ Select(H1,H2)$	61	User Lamp Output # 2	UF2	User lamp output control unit #2
13	High Limiter	HLM	Limiting at high limit value(H2)	62	Time-% Conversion	TTP	$OUT=(H1-P1/P2-P1)*100$
14	High Monitor	HMS	Output turned on when higher than Hi monitor value(H2)	63	%-Time Conversion	PTT	$OUT=H1*(P2-P1)+P1$
15	Low Monitor	LMS	Output turned on when lower than Lo monitor value(H2)	64	—* ¹	—	—
16	Deviation Monitor	DMS	Output turned on when higher than deviation monitor value(H2)	65	—* ¹	—	—
17	Deviation Rate Limit	DRL	Deviation rate limited within H2 or -P1%/minute.	66	Integral Unit* ¹	INT	$OUT=H1/(P1 \cdot S)$
18	Deviation Rate Monitor	DRM	Output turned on when deviation rate is more than H2 or -P1%/minute.	67	Parameter Scheduling # 1* ¹	PS1	Changes control parameter according to load input.
19	Manual Output	MAN	Operation with manual loader	68	Parameter Scheduling # 2* ¹	PS2	Changes control parameter according to load input.
20	Controller # 1	PID1	PID Control with self-tuning function	69	Parameter Scheduling # 3* ¹	PS3	Changes control parameter according to load input.
21	Controller # 2	PID2	PID Control with self-tuning function	70	Parameter Scheduling # 4* ¹	PS4	Changes control parameter according to load input.
22	Dead Time	DED	$OUT=e^{-P1S}*H1$	71	Parameter Scheduling # 5* ¹	PS5	Changes control parameter according to load input.
23	Lead/Lag	L/L	$OUT=(1+P1S)/(1+P2S)*H1$	72	Parameter Scheduling # 6* ¹	PS6	Changes control parameter according to load input.
24	Derivative	LED	$OUT=P1S/(1+P2S)*H2$	73	% - % Table # 1 * ¹	PTB1	% - % Table #1(11 breaking points)
25	Moving Average	MAV	$OUT=\frac{1}{16}\sum_{i=0}^{15}H1(\frac{i}{16}P1)$ (H1=Input at P1 minutes ago)	74	% - % Table # 2 * ¹	PTB2	% - % Table #2(11 breaking points)
26	Flip-Flop	RS	RS flip-flop	75	% - % Table # 3 * ¹	PTB3	% - % Table #3(11 breaking points)
27	Logical Product	AND	$OUT=H1\wedge H2\wedge P1\wedge P2$	76	% - % Table # 4 * ¹	PTB4	% - % Table #4(11 breaking points)
28	Logical Sum	OR	$OUT=H1\vee H2\vee P1\vee P2$	77	% - Time Table # 1 * ¹	TTB1	% - Time Table #1(11 breaking points)
29	Exclusive Logical Sum	XOR	$OUT=H1\vee\wedge H2$	78	% - Time Table # 2 * ¹	TTB2	% - Time Table #2(11 breaking points)
30	Invert	NOT	$OUT=\bar{H1}$	79	% - Time Table # 3 * ¹	TTB3	% - Time Table #3(11 breaking points)
31	2-Position Transfer Switch	SW	H1/H2 selector switch	80	% - Time Table # 4 * ¹	TTB4	% - Time Table #4(11 breaking points)
32	Bumpless Transfer Switch	SFT	Switching with bump suppression.	81	Alternate Switch* ¹	ALSW	Reversing output at H1=ON
33	Timer	TIM	Pulse generation per P1 minutes.	82	Time Switch* ¹	TSW	Selection switches H1,H2 (Time)
34	Integration Pulse Output	CPO	Pulse number output proportional to input H2.	83	Flag Switch* ¹	FSW	Selection switches H1,H2 (Flag)
35	Ramp Signal Generation	RMP	Output increase at constant rate.	84	On Delay Timer* ¹	ONDT	Output turned ON after P1 time at H1=ON.
36	Pulse Width Modulation	PWM	Pulse output with duty ratio proportional to input H1, with period P1.	85	Off Delay Timer* ¹	OFDT	Output turned OFF after P1 time at H1=OFF.
37	Linearization Table # 1	TBL1	Linearization table #1(10 breaking points)	86	One-shot Timer* ¹	OST	Output turned ON for P1 time at H1=ON.
38	Linearization Table # 2	TBL2	Linearization table #2(10 breaking points)	87	Hi/Lo Limiter* ¹	HLLM	Limiter activated at Hi(P1) or Lo(P2) value.
39	Linearization Table # 3	TBL3	Linearization table #3(10 breaking points)	88	Integration Pulse Output II	CPX	Pulse number output equivalent to integration range
40	Reverse Linearization Table # 1	TBR1	Reverse function of Linearization table #1.	89	Data Hold	HOLD	One cycle hold value output at startup
41	Reverse Linearization Table # 2	TBR2	Reverse function of Linearization table #2.	90	Raise/Lower Unit* ¹	RL	Output decreased or increased according to H1, or H2.
42	Reverse Linearization Table # 3	TBR3	Reverse function of Linearization table #3.	91	Reset Unit* ¹	RST	Resets interlock.
43	Control Parameter Change # 1	PMD1	Change of control of PID 1.	92	Digital Indication* ¹ Change # 1	DDM1	Changes digital indication #1.
44	Control Parameter Change # 2	PMD2	Change of control of PID 2.	93	Digital Indication* ¹ Change # 2	DDM2	Changes digital indication #2.
45	Mode Select (switch detection)	MOD	M/A/C/F mode change	94	Digital Indication* ¹ Change # 3	DDM3	Changes digital indication #3.
46	Linearization Table # 4	TBL4	Linearization table #4(11 breaking points)	95	Digital Indication* ¹ Change # 4	DDM4	Changes digital indication #4.
47	Linearization Table # 5	TBL5	Linearization table #5(11 breaking points)	96	Digital Indication* ¹ Change # 5	DDM5	Changes digital indication #5.
48	Linearization Table # 6	TBL6	Linearization table #6(11 breaking points)	97	Digital Indication* ¹ Change # 6	DDM6	Changes digital indication #6.
49	Reverse Linearization Table # 4	TBR4	Reverse function of Linearization table #4.	98	Display Change* ¹	DCHG	Changes display.

Note*¹) No.55 & No.64 through 98 are not supported on PC Communicator (IBM-Compatible Version).

Standard specifications

		Item	Description
Input Section	Analog Input	No.of inputs Input voltage Input impedance Receiving system Allowable input overvoltage	7 points (programmable : 6, for stand-by PV input : 1) 1 to 5V dc Power-on : 5M Ω , Power-off : 60k Ω Differential type receive, not isolated \pm 30V dc maximum
	Digital Input	No.of inputs Input voltage Input bias current Allowable input overvoltage	6 points (programmable : 5, external interlock signal : 1) Low : 0 to 4V dc, High : 10 to 30V dc Low : 3mA dc or less, High : 10 μ A dc or less \pm 30V dc maximum
Output Section	Analog Output	Voltage	No.of outputs Output voltage Output impedance Output system
		Current	No.of outputs Output current Output impedance Allowable load Output system
	Digital Output	No.of outputs Output system Contact rating	3 points 1 to 5V dc 250 Ω Differential output system
		No.of outputs Output system Contact rating	1 point 4 to 20mA dc 250k Ω 500 Ω (preset type), 600 Ω (follow-up type or unit not mounted) Minus common
Indicator Section	Input	No.of indications Type of indicator Indicating accuracy	6 points (programmable : 5, stand-by mode output : 1) Transistor output (open collector) 30V dc, 0.2A dc (resistive load)
		No.of indications Type of indicator Indicating accuracy	2 points (SP : green, PV : red) Simultaneous bar graph (% in color LCD) and digital value (engineering units) displays (bar graph : 53 segments, digital value : 7 segments (4 digits)) Digital indication : \pm 0.15% FS \pm 1 digit, bar graph resolution : 2%
	Output	No.of indications Indication system Indicating accuracy	1 points (OUT : yellow) Simultaneous bar graph (% in color LCD) and digital value (engineering units) displays (bar graph : 23 segments, digital value : 7 segments (4 digits)) Digital indication : \pm 0.25% FS \pm 1 digit, bar graph resolution : 5%
		No.of indications Indication system	5 points (process alarm : 2, user lamp : 2, equipment alarm : 1) Color LCD and LED lamp
Mode indication		Character indication by color LCD	
Operating Section	Operation control buttons		SP raise/lower buttons : 2 Output raise/lower buttons : 2 SP, output raise/lower acceleration button : 1 Mode switch buttons : 3 Reset button : 1 Definitive buttons for user : 1
	Data Setter	Indicating method	LCD (16 digits)
		No.of setting buttons Parameter tuning	24 (including display change button) PID Parameter Proportional band : 0.0 to 799.9% Reset time : 0.00 to 99.99min. Rate time : 0.00 to 99.99min. Reset upper/lower limit, Ratio, Bias, Dead band, Output deviation rate limit, Deviation alarm, PV alarm upper/lower limit, Analog input processing, Digital filtering, Engineering unit upper/lower limit Variable parameters % : -699.9 to 799.9% Time : 0.00 to 99.99min. Flag : On/off Parameters for self-tuning Proportional band upper/lower limit, Reset time upper/lower limit, Rate time upper/lower limit, Rate time dropout, Decision rule : Giegler-Nichols/Chien
	Auxiliary switches		Data entry enabling : 1 Start-up method switching : 1 Direct/reverse selectors : 2 Higher-order writing enabling : 1 Communication enabling : 1 Calibration switch : 1 Communicator switch : 1

General Specifications	Power supply	24V dc $\begin{matrix} +15\% \\ -10\% \end{matrix}$
	Power consumption	400mA dc maximum (24V dc. without option)
	Signal line connection	Instrument back-panel terminal connection. connecting line diameter : 1.25mm ² maximum
	Power interruption/failure	16V dc or over, within 200 msec. (with STX type power supply) Data holding at power interruption <ul style="list-style-type: none"> • User program : Backup by EEPROM • Control data (SP.OUT.mode) : RAM backup by super capacitor (72 hours) Power failure reset function : <ul style="list-style-type: none"> • HOT start (Operation resumes from prefailure status) • COLD start (Operation starts from preset value)
	Ambient temperature	0 to 50°C
	Ambient humidity	10 to 90% RH
	Installation	Panel flush mount, indoor installation
	Mounting angle	Horizontal (Instrument back can be slanted 60 maximum from horizontal position.)
	Finish	Case : Dark beige Bezel : Black
	Weight	3.0kg (without standby manual unit)

Optional specifications

Item	Description
① Standby manual unit (Preset type / follow-up type)	No.of indications : 1 point (with OUT/PV switch ; A-type, preset B-type; without indication, follow-up B-type ; output only.) Indicating system : Moving coil type (A-type) LED bar graph type (follow-up type-B only) Indicating accuracy : $\pm 5\%$ FS Power supply : 24V dc Output impedance : 250k Ω Allowable load : Preset type ; 500 Ω Follow-up type ; 600 Ω Power consumption : Preset type ; 60mA maximum (24V dc) Follow-up type ; 120mA dc maximum (24V dc)
② Communication interface	S-link communication : 48k bits/sec. Transmission system : Complies with HDLC Transmission distance : 200m total Host : SSC Port,LCl

Model number table

Basic Model No.	Selections	Options			Description
	Main Power Supply	I	II	III	
KAM111					Programmable controller A/M, SP operation available (See Note)
KAM211					Programmable controller C/A/M, SP operation available (See Note)
	-0				24V dc
		-0			Without communication interface
		-1			With communication interface
			0		Without self-tuning function
			1		With self-tuning function
				0	Without standby manual unit
				1	With standby manual unit (preset type A)
				2	With standby manual unit (follow-up type A)
				3	With standby manual unit (preset type B)
				4	With standby manual unit (follow-up type B)

Note) Non-SI units (kgf/cm², etc.) and SI units (Pa: Pascal) are selectable in the pressure compensation.

Connection

1	2	23	24
3	4	25	26
5	6	27	28
7	8	29	30
9	10	31	32
11	12	33	34
13	14	35	36
15	16	37	38
17	18	39	40
19	20	41	42
21	22	43	44

No.	Symbol	Contents	No.	Symbol	Contents
1	+24V	Instrument main power ⊕	23	AIR1+	1-5V dc input ⊕
2	SM+24V	Standby manual power ⊕	24	AIR1-	1-5V dc input ⊖
3	AO1+	4-20mA dc output ⊕	25	AIR2+	1-5V dc input ⊕
4	AO1-	4-20mA dc output ⊖	26	AIR2-	1-5V dc input ⊖
5	AOV1+	1-5V dc output ⊕	27	AIR3+	1-5V dc input ⊕
6	AOV1-	1-5V dc output ⊖	28	AIR3-	1-5V dc input ⊖
7	AOV2+	1-5V dc output ⊕	29	AIR4+	1-5V dc input ⊕
8	AOV2-	1-5V dc output ⊖	30	AIR4-	1-5V dc input ⊖
9	AOV3+	1-5V dc output ⊕	31	AIR5+	1-5V dc input ⊕
10	AOV3-	1-5V dc output ⊖	32	AIR5-	1-5V dc input ⊖
11	OV	For Power, DO1 to 5, and S common	33	AIR6+	1-5V dc input ⊕
12	OV		34	AIR6-	1-5V dc input ⊖
13	DO1	Digital output #1	35	OV	For DI1 to 5, and interlock common
14	DO2	Digital output #2	36	OV	
15	DO3	Digital output #3	37	DI1	Digital input #1
16	DO4	Digital output #4	38	DI2	Digital input #2
17	DO5	Digital output #5	39	DI3	Digital input #3
18	S	Standby mode output	40	DI4	Digital input #4
19	SMPV+	For standby unit, PV ⊕	41	DI5	Digital input #5
20	SMPV-	For standby unit, PV ⊖	42	INT'K	External interlock signal input
21	GND	Chassis ground	43	LINK+	S-link ⊕
22	GND	Chassis ground	44	LINK-	S-link ⊖

Dimensions

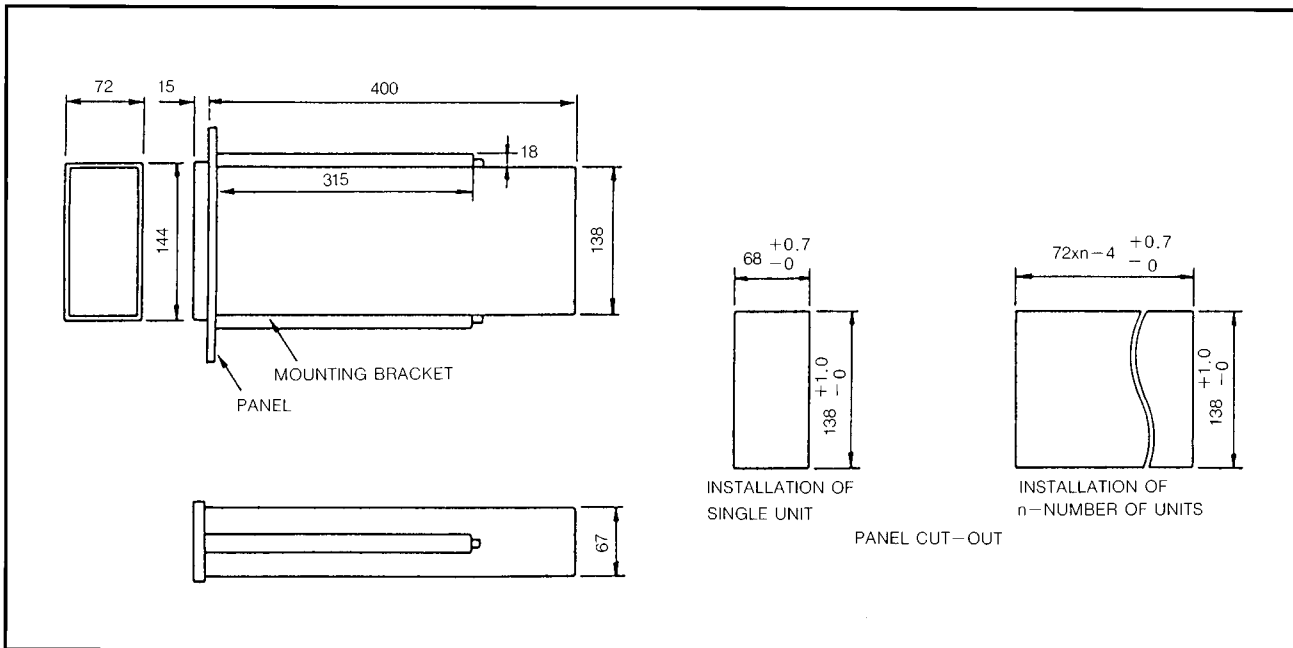

Ordering Information

When ordering, please specify :

- 1) Model No.
- 2) Scale range
- 3) Tag No.

Specifications are subject to change without notice.

Yamatake Corporation

Totate International Building
2-12-19 Shibuya
Shibuya-ku Tokyo 150-8316
Tel : 81-3-3486-2216
Fax : 81-3-3486-2503

Yamatake-SIC Control Systems Co., Ltd. : China 86-10-6510-2505
Shanghai Yamatake Jinshan Control Instruments Co., Ltd. : China 86-21-6428-8661
Yamatake Korea Co., Ltd. : Korea 82-2-785-0280-2
Yamatake Taiwan Co., Ltd. : Taiwan 886-2-2501-1066
Yamatake (Thailand) Co., Ltd. : Thailand 66-2-210-0900-7
Yamatake Philippines, Inc. : Philippines 63-2-817-6452
PT. Yamatake Berca Indonesia : Indonesia 62-21-230-5538
Yamatake Controls Singapore Pte. Ltd. : Singapore 65-778-5966
Yamatake Automation (M) Sdn. Bhd : Malaysia 60-3-706-5740
YCV Corporation : U.S.A. 1-281-880-8188

Yamatake Industrial Systems Co.,Ltd.

This has been printed on recycled paper.

YAMATAKE

Savemation

Saving through Automation

<http://www.yis.yamatake.co.jp/>

0301-Y/Y