

Module Type Controller DMC50

User's Manual Installation and Configuration



Thank you for purchasing DMC50.
This manual contains information for ensuring correct use of DMC50. It also provides necessary information for installation, maintenance, and troubleshooting.
This manual should be read by those who design and maintain equipment that use DMC50.
Be sure to keep this manual nearby for handy reference.

RESTRICTIONS ON USE

This product has been designed, developed and manufactured for general-purpose application in machinery and equipment. Accordingly, when used in the applications outlined below, special care should be taken to implement a fail-safe and/or redundant design concept as well as a periodic maintenance program.

- Safety devices for plant worker protection
- Start/stop control devices for transportation and material handling machines
- Aeronautical/aerospace machines
- Control devices for nuclear reactors

Never use this product in applications where human safety may be put at risk.

REQUEST

Ensure that this User's Manual is handed over to the user before the product is used.

Copying or duplicating this User's Manual in part or in whole is forbidden. The information and specifications in this User's Manual are subject to change without notice.

Considerable effort has been made to ensure that this User's Manual is free from inaccuracies and omissions.

If you should find any inaccuracies or omissions, please contact Yamatake Corporation.

In no event is Yamatake Corporation liable to anyone for any indirect, special or consequential damages as a result of using this product.

©2002 Yamatake Corporation ALL RIGHTS RESERVED

Ethernet® is a registered trademark of Xerox Corp.

ISaGRAF® is a registered trademark of AlterSys Inc.

DMC50 and SLP-D50 are the trademarks of Yamatake Corporation.

Other company names and product names listed in this manual are registered trademarks or trademarks of respective companies.

SAFETY PRECAUTIONS

■ About Icons

Safety precautions are for ensuring safe and correct use of this product, and for preventing injury to the operator and other people or damage to property. You must observe these safety precautions. The safety precautions described in this manual are indicated by various icons.

As the following describes the icons and their meanings, be sure to read and understand the descriptions before reading this manual:



WARNING

Warnings are indicated when mishandling this product might result in death or serious injury to the user.









CAUTION

Cautions are indicated when mishandling this product might result in minor injury to the user, or only physical damage to this product.









■ Examples

	<p>Triangles warn the user of a possible danger that may be caused by wrongful operation or misuse of this product.</p> <p>These icons graphically represent the actual danger. (The example on the left warns the user of the danger of electrical shock.)</p>
	<p>White circles with a diagonal bar notify the user that specific actions are prohibited to prevent possible danger.</p> <p>These icons graphically represent the actual prohibited action. (The example on the left notifies the user that disassembly is prohibited.)</p>
	<p>Black filled-in circles instruct the user to carry out a specific obligatory action to prevent possible danger.</p> <p>These icons graphically represent the actual action to be carried out. (The example on the left instructs the user to remove the plug from the outlet.)</p>

WARNING

	Before removing / mounting or wiring the DMC50, be sure to turn the source power OFF. Doing so might cause electric shock.
	Do not touch any terminals or metal parts connected to the DMC50 when mounting or dismounting this instrument. Doing so might cause electric shock.
	Do not disassemble the DMC50. Doing so might cause electric shock or faulty operation.
	Ground the FG terminal with a ground resistance of a maximum of 100 Ω before connecting this instrument to the measurement target or external control circuits. Failure to do so might cause electric shock or fire.
	Do not touch electrically charged parts such as the power terminals. Doing so might cause electric shock.
	Provide safety measures externally for this instrument so that the entire system can operate safely even in the event of this instrument malfunctioning or if any abnormality as a result of some external cause occurs. Faulty operation of this instrument could result in serious injury or accident.

CAUTION

	Use the DMC50 within the operating ranges recommended in the specifications (temperature, humidity, voltage, vibration, shock, mounting direction, atmosphere, etc.). Failure to do so might cause fire or faulty operation.
	Do not block ventilation holes. Doing so might cause fire or faulty operation.
	Do not allow lead clippings, chips or water to enter the DMC50 case. Doing so might cause fire or faulty operation.
	Wire the DMC50 properly according to predetermined standards. Also wire the DMC50 using designed power leads according to recognized installation methods. Failure to do so might cause electric shock, fire or faulty operation.
	Inputs to the current input terminals (2•4, 6•8, 10•12, 14•16) on this instrument should comply within the electrical current limit stated in the specifications irrespective of the operating conditions of this instrument. Failure to do so might cause fire or faulty operation.
	Firmly tighten the terminal screws and mounting screw at the torque listed in the specifications. Insufficient tightening of terminal screws might cause electric shock or fire.
	Do not use unused terminals on the DMC50 as relay terminals. Doing so might cause electric shock, fire or faulty operation.
	We recommend attaching the terminal cover after wiring the DMC50. Failure to do so might cause electric shock.

The Role of This Manual

Seven different manuals in total are available for DMC50. Read each manual according to your specific requirements. Following is a brief outline of each of the manuals.

To obtain manuals, contact Yamatake Corporation or your Yamatake dealer.

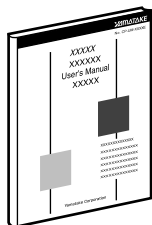

Module Type Controller DMC50 User's Manual "Installation and Configuration" **Manual No. CP-SP-1139E**

This Manual.

Thoroughly read this manual before designing or manufacturing the equipment hardware using DMC50.

This manual consists of two parts, one for the control module and the other for the communication module. It describes the installation, wiring, specifications, and hardware troubleshooting of those controller.

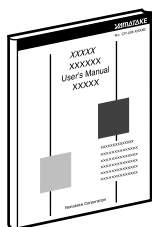

Module Type Controller DMC50 User's Manual "QuickStart" **Manual No. CP-SP-1092E**

The user who operates DMC50 for the first time must read this manual thoroughly. This manual is intended to help the user understand the overview of the controller operation and basic operating procedures.

The manual describes the operation with various examples. Read this manual while using the smart loader package.

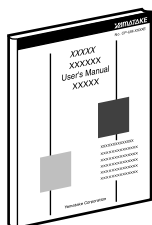

Module Type Controller DMC50 User's Manual "Communications Connection" **Manual No. CP-SP-1093E**

The user who uses the communication facilities of DMC50 must read this manual thoroughly. This manual describes the communication facilities of this controller, such as CPL communication and Ethernet communication.

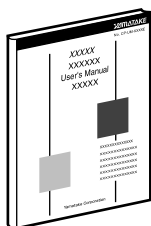

Module Type Controller DMC50 User's Manual "Function Block Reference" **Manual No. CP-SP-1130E**

Read this manual when the user designs a control system most suitable for the user's application by utilizing DMC50.

This manual describes the specifications of ISaGRAF functions and function blocks essential to design a desired control system.

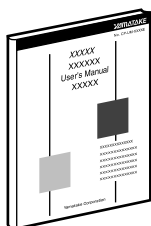

Module Type Controller DMC50 User's Manual "Application Developer's Guide" **Manual No. CP-SP-1134E**

This manual describes how to write practical application programs for the DMC50. The person in charge of programming is encouraged to read this manual thoroughly.

This manual describes the pattern function blocks, utilization of ISaGRAF, and application examples.

This manual is intended for the user who has already read the separate manual "QuickStart" and "Function Block Reference" thoroughly to fully understand their contents.

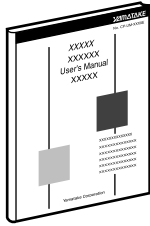

**Smart Loader Package SLP-D50 for Module Type Controller DMC50
User's Manual** **Manual No. CP-SP-1122E**

This manual describes the operations and features of the smart loader package SLP-D50 for DMC50 as well as its installation into a personal computer. It also writes about important points collaborating with ISaGRAF to build an application for the controller.



SLP-D50J50 Installation Guide **Manual No. CP-UM-5259 / E**

This manual describes how to install the smart loader package SLP-D50 for the DMC50 into a personal computer.

Organization of This User's Manual

The DMC50 has two modules, control module (hereafter referred to as CTRL module) and communication module (hereafter referred to as COM module).

Therefore, the contents of this manual are also separated into two parts, "Control module" and "Communication module".

The description of each module is self-contained in each part. Read the contents of relevant part for the module that the user wishes to use.

Control module

- | | |
|--------------------|---|
| Chapter 1. | OVERVIEW
This chapter describes the overview of the CTRL module. |
| Chapter 2. | NAMES AND FUNCTIONS OF PARTS
This chapter describes the names and functions of the parts of the CTRL module. |
| Chapter 3. | INSTALLATION
This chapter describes how to install and mount the CTRL module. |
| Chapter 4. | WIRING
This chapter describes how to make wiring the CTRL module, how to use the connectors, and how to connect modules. |
| Chapter 5. | MODES
This chapter describes the modes of the CTRL module. |
| Chapter 6. | APPLICATION PROGRAM
This chapter describes the explanation and cautions about the ISaGRAF necessary to create application programs using the CTRL module. |
| Chapter 7. | PARAMETERS
This chapter describes the setting items and their usages for the CTRL module. |
| Chapter 8. | DATA ADDRESSES
This chapter describes the data addresses used for the CPL communication. |
| Chapter 9. | MAINTENANCE AND TROUBLESHOOTING
This chapter describes how to locate the cause of a trouble that may occur in the CTRL module, take corrective actions, and perform the maintenance work. |
| Chapter 10. | SPECIFICATIONS
This chapter describes the general specifications, communication specifications, module specifications, and outside dimensions of the CTRL module. |
| APPENDIX | This chapter describes the supplemental explanation about the CTRL module. |

Communication module

- Chapter 1. OVERVIEW**
This chapter describes the overview of the COM module.
- Chapter 2. NAMES AND FUNCTIONS OF PARTS**
This chapter describes the names and functions of the parts of the COM module.
- Chapter 3. INSTALLATION**
This chapter describes how to install and mount the COM module.
- Chapter 4. WIRING**
This chapter describes how to make wiring the COM module, how to use the connectors, and how to connect modules.
- Chapter 5. PARAMETERS**
This chapter describes the setting items and their usages for the COM module.
- Chapter 6. DATA ADDRESSES**
This chapter describes the data addresses used for the CPL communication.
- Chapter 7. MAINTENANCE AND TROUBLESHOOTING**
This chapter describes how to locate the cause of a trouble that may occur in the COM module, take corrective actions, and perform the maintenance work.
- Chapter 8. SPECIFICATIONS**
This chapter describes the general specifications, communication specifications, module specifications, and outside dimensions of the COM module.
- APPENDIX**
This chapter describes the supplemental explanation about the COM module.

Contents

SAFETY PRECAUTIONS

The Role of This Manual

Organization of This User's Manual

Conventions Used in This Manual

Introduction

Control module

Chapter 1. OVERVIEW

- Features A-1-1
- Model selection guide A-1-2
- Examples of system configurations A-1-3

Chapter 2. NAMES AND FUNCTIONS OF PARTS

- Body and base A-2-1
- Terminal block A-2-1
- Front view A-2-2
- Input / output configuration of CTRL module A-2-3
- LED indications A-2-4
- Rotary switch A-2-4
- Analog input types A-2-4
- Analog output types A-2-6
- Auxiliary input types A-2-6
- Digital input types A-2-6
- Digital output types A-2-6
- Communication types A-2-6

Chapter 3. INSTALLATION

- Installation place A-3-1
- Connecting modules A-3-2
- Mounting A-3-2

Chapter 4. WIRING

- 4-1 Wiring precautions A-4-1
 - Wiring diagram labels A-4-2
- 4-2 Connections A-4-4
 - Connecting the power supply A-4-5
 - Grounding A-4-6
 - Connecting wires to the terminal block A-4-7
 - Connecting connectors A-4-9
 - Connecting the loader A-4-9
 - Linking Modules A-4-9
 - Connecting with the extension base A-4-10

■ Operator Interface Terminal(OIT) communication	A-4-11
■ Connecting analog inputs	A-4-12
■ Connecting analog outputs	A-4-14
■ Connecting auxiliary inputs	A-4-15
■ Connecting digital inputs / outputs	A-4-16
■ Recommended cables	A-4-17
■ Isolation between input and output	A-4-18

Chapter 5. MODES

5-1 Modes of operation	A-5-1
■ Application inactive mode	A-5-1
■ Application operating mode	A-5-2
5-2 Mode transitions	A-5-4
■ Mode at power ON	A-5-4
■ Starting of application (From Application inactive mode to Operating mode)	A-5-4
■ Stopping of application (From Operating mode to the Application inactive mode)	A-5-4
■ Real time mode and Cycle to cycle mode	A-5-4

Chapter 6. APPLICATION PROGRAM

6-1 About ISaGRAF	A-6-1
6-2 Application program execution	A-6-2
■ Flow of execution	A-6-2
■ Cautions for execution	A-6-3

Chapter 7. PARAMETERS

7-1 Parameter lists	A-7-1
7-2 System Parameters	A-7-5
■ AI Setup (High resolution type: for standard inputs)	A-7-5
■ AI Setup (High resolution type: for option inputs)	A-7-10
■ AI Setup (Special type)	A-7-14
■ AUX-IN Setup	A-7-16
■ Zener Barrier Adjustment Values	A-7-19
■ AO Setup	A-7-19
■ DO Setup	A-7-24
■ TP Setup	A-7-25
■ Date and Time Setup	A-7-26
■ Front Port Communication Setup	A-7-27
7-3 System Monitor Parameters	A-7-28
■ System Alarm Log	A-7-28
■ AI Alarm Log	A-7-29
■ AUX-IN Alarm Log	A-7-30
■ H / W Info	A-7-31
■ System Status	A-7-32

■ Date and Time Display	A-7-33
■ AI Status	A-7-33
■ AUX-IN Status	A-7-34
■ AO Status	A-7-34
■ DI Status	A-7-35
■ DO Status	A-7-36
■ TP Status	A-7-37
■ Zener Barrier Adjustment Counts	A-7-38
■ Front Port Active Communication Setup	A-7-38
■ Memory Usage Monitor	A-7-39

Chapter 8. DATA ADDRESSES

8-1 Data address structure	A-8-1
■ About PA and NA	A-8-1
■ Network Address (NA) structure	A-8-2
■ Parameter Address (PA) structure	A-8-2
8-2 Data address list (NA area)	A-8-3
8-3 Data address list (PA area)	A-8-4

Chapter 9. MAINTENANCE AND TROUBLESHOOTING

■ Maintenance	A-9-1
■ Troubleshooting	A-9-2

Chapter 10. SPECIFICATIONS

■ General specifications	A-10-1
■ Communication specifications	A-10-3
■ Module types and input / output points	A-10-4
■ Analog inputs	A-10-4
■ Analog outputs	A-10-10
■ Auxiliary inputs	A-10-12
■ Digital inputs	A-10-13
■ Digital outputs	A-10-13
■ Outside dimensions	A-10-14

Appendix

System Status bit data	A-App-1
■ System Alarms	A-App-1
■ AI Alarms	A-App-3
■ AUX-IN Alarms	A-App-5
Logging capability	A-App-6
■ About logging capability	A-App-6
■ Update time and the number of logging records	A-App-6
ISaGRAF variables and Parameter data types	A-App-7
■ ISaGRAF variable data types	A-App-7
■ Parameter data types	A-App-7

Relationship among System Monitor Parameters and I / O variables	A-App.-9
■ About System Monitor Parameters	A-App.-9
■ About I / O variables	A-App.-9
■ Analog inputs (AI1 to AI4, option AI1 to option AI4)	A-App.-10
■ Auxiliary inputs (AUX-IN1 to AUX-IN2)	A-App.-10
■ Analog outputs (AO1 to AO4)	A-App.-10
■ Digital inputs (DI1 to DI12)	A-App.-11
■ Digital outputs (DO1 to DO16, TP1 to TP16)	A-App.-11
Burnout indication	A-App.-12
■ Analog inputs	A-App.-12
■ Auxiliary inputs	A-App.-13
How to adjust the zener barrier	A-App.-14
■ Conditions allowing adjustment and correction of zener barrier	A-App.-14
■ How to adjust the zener barrier	A-App.-14
AO, DO, and TP preset / bumpless operation	A-App.-15
■ [Output Not in Operating Mode] is set at [Preset Output Value].	A-App.-15
■ [Output not in Operating Mode] is set at [Bumpless Transfer].	A-App.-15
Downloading data and memory capacity	A-App.-16
■ Download size list	A-App.-16
■ Application code	A-App.-16
■ ISaGRAF variables and FB instances	A-App.-18
■ ISaGRAF retained variables	A-App.-20
■ Calculation Parameters, Calculation Monitor Parameters, Program Pattern Parameters, and User-defined Parameters	A-App.-21

Communication module

Chapter 1. OVERVIEW

- Features B-1-1
- Model selection guide B-1-1
- Examples of system configurations B-1-2

Chapter 2. NAMES AND FUNCTIONS OF PARTS

- Body and base..... B-2-1
- Terminal block..... B-2-1
- Front view B-2-2
- Input / output configuration of COM module..... B-2-2
- LED indications..... B-2-3
- Rotary switch..... B-2-3
- Communication types B-2-4

Chapter 3. INSTALLATION

- Installation place B-3-1
- Connecting modules..... B-3-2
- Mounting B-3-2

Chapter 4. WIRING

- 4 - 1 Wiring precautions B-4-1
 - Wiring diagram labels B-4-2
- 4 - 2 Connections..... B-4-3
 - Connecting the power supply B-4-4
 - Grounding B-4-5
 - Connecting wires to the terminal block..... B-4-6
 - Connecting the loader B-4-8
 - Linking Modules B-4-8
 - Connecting with the extension base..... B-4-9
 - Operator Interface Terminal(OIT) communication B-4-10
 - Connecting wires for communications B-4-11
 - Connecting to 5-wire device..... B-4-12
 - Connecting to 3-wire device..... B-4-13
 - Example of connection with EST240Z..... B-4-14
 - Recommended cables..... B-4-15
 - Isolation between input and output..... B-4-15

Chapter 5. PARAMETERS

5 - 1 Parameter lists	B-5-1
5 - 2 System Parameters	B-5-2
■ Date and Time Setup	B-5-2
■ ME20X Communication Setup	B-5-3
■ MR20X Communication Setup	B-5-6
■ Front Port Communication Setup	B-5-6
5 - 3 System Monitor Parameters	B-5-8
■ System Alarm Log	B-5-8
■ H / W Info	B-5-9
■ System Status	B-5-10
■ Date and Time Display	B-5-11
■ ME20X Active Communication Setup	B-5-11
■ MR20X Active Communication Setup	B-5-12
■ Front Port Active Communication Setup	B-5-12
■ MAC Address	B-5-13

Chapter 6. DATA ADDRESSES

6 - 1 Data address structure	B-6-1
■ About PA	B-6-1
■ Parameter Address (PA) structure	B-6-1
6 - 2 Data address list (PA area)	B-6-2

Chapter 7. MAINTENANCE AND TROUBLESHOOTING

■ Maintenance	B-7-1
■ Troubleshooting	B-7-2

Chapter 8. SPECIFICATIONS

■ General specifications	B-8-1
■ Communication specifications	B-8-2
■ Outside dimensions	B-8-4

APPENDIX

System Status bit data	B-App.-1
■ System Alarms	B-App.-1
Logging capability	B-App.-2
■ About logging capability	B-App.-2
■ Update time and the number of logging records	B-App.-2
Parameter data types	B-App.-3
■ Parameter data types	B-App.-3

Conventions Used in This Manual

The following conventions are used in this manual:

 **Handling Precaution**

: Handling Precautions indicate items that the user should pay attention to when handling DMC50.

 **Note**

: Notes indicate useful information that the user might benefit by knowing.



: This indicates the item or page that the user is requested to refer to.

(1), (2), (3)

: The numbers with the parenthesis indicate steps in a sequence or indicate corresponding parts in an explanation.

Ethernet ®

: This is referred to as "Ethernet" in this manual.

Introduction

■ Overview

DMC50 is a module type multi-loop controller for high precision control of analog process variables, such as temperature, flow rate, pH, and liquid level.

- Two modules are provided in the product line-up, CTRL module to control analog process variables and COM module to perform the digital communication.
- The CTRL module features multiple advanced PID controller functions and various auxiliary operation functions that provide high accuracy, high stability, and excellent response. This allows the user to freely organize process logic for sophisticated equipment designs.
- The COM module is equipped with the RS-485 communication capability, as well as Ethernet communication capability. This module is flexibly applicable to all systemization needs.
- The CTRL module is equipped with multiple analog inputs / outputs, multiple digital inputs / outputs, and communications capabilities so that a module can operate alone. Therefore, the CTRL modules can be installed separately.
- Furthermore, the CTRL module is equipped with ISaGRAF(*) to allow designing of a desired control system and is applicable to the user's various requirements.

* ISaGRAF®

ISaGRAF is a control application development environment in conformity with IEC61131-3 and a registered trademark of Alter Sys.

■ Features

● Features common to both modules

- High reliability : Designed to operate continuously for 5 years (45,000 hours) at an ambient temperature of 50°C and a load of 80%.
- Maintenance : The base, the body, and the terminal block can be separated, ensuring excellent maintenance ability.
- Wiring saving : Through connected bases, electric power is supplied to each individual module and the data can be exchanged between the modules, resulting in saving wiring costs.

■ How to select a module

Application	Module type
For general control requiring high stability	CTRL module High resolution 2-loop type (CH20X module) High resolution 4-loop type (CH40X module)
For control requiring higher resolution with RTD	CTRL module Special 2-loop type (CS20X module) Special 4-loop type (CS40X module)
For host communication	COM module Ethernet type (ME20X module) RS-485 type (MR20X module)

A model selection guide is provided in each part: Control module and Communication module.



Control module

Chapter 1. OVERVIEW

■ Features

● CTRL module

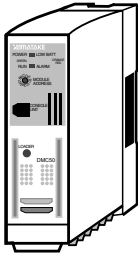

- Processing with a high resolution is possible.
 - Thermocouple input : 1 / 100°C resolution in a specific range.
 - RTD input : 1 / 5000°C resolution (special module)
 - 4 to 20 mA input : 1 / 32000 resolution
- Many analog process variables can be processed.
 - Analog input : 4 universal inputs (Max. 8 inputs for voltage or thermocouple inputs). In addition to these inputs, 2 auxiliary inputs are provided.
 - Analog output : 4 points
- Digital input and output signals are provided.

These signals are used for relay sequence inputs / outputs, such as interlock signals and operation signals.

 - Digital input : 12 photo-coupler inputs
 - Digital output : 16 transistor outputs
- A development environment is provided, which is used to freely design an advanced control process.
 - Operation types : More than 100 types, such as arithmetic, logic, and PID control operations, etc.
 - Computing capacity : More than 8-loop calculations are possible regarding the PID computing capacity.
 - Language : An optimum language can be selected, suitable for writing an advanced process program.
 - Highly efficient program development is possible based on the concept in conformity with IEC61131-3. This achieves reuse of the programs.
 - Easy-to-use features for a process controller is considered, such as Parameter setting capability and trend monitor.
- An optimal computing speed most suitable for the pressure, flow rate, and fast temperature ramp-up control is achieved.
 - An update cycle of 50 ms is achieved for the input / output and operation, and is applicable to applications requiring high-speed responses .
- Strengthened stability and overshoot control algorithms are built-into the CTRL module.
 - Controllability that cannot be accomplished by means of conventional methods becomes possible with utilization of highly accurate control algorithm "RationalLOOP" for direct heating systems requiring the advanced control.

■ Model selection guide

Basic model	Module type	Additional treatment	Special treatment	Description
DMC50				Module type controller
	CH40X			CTRL module, high resolution 4-loop type
	CH20X			CTRL module, high resolution 2-loop type
	CS40X			CTRL module, special 4-loop type
	CS20X			CTRL module, special 2-loop type
	XXXX0			Standard base type (connector connection type)
	XXXX1			Extension base type (terminal connectable type)
		0 0		No additional treatment
		T 0		Tropicalization
		K 0		Anti-sulfide treatment
		D 0		Inspection Certificate provided
		B 0		Tropicalization and inspection certificate provided
		L 0		Anti-sulfide treatment and inspection certificate provided
		0 Y		Complying with the traceability certification
		T Y		Tropicalization and complying with the traceability certification
		K Y		Anti-sulfide treatment and complying with the traceability certification
			0 0 0 0	No special treatment

■ Examples of system configurations

● CTRL modules are combined with a COM module:

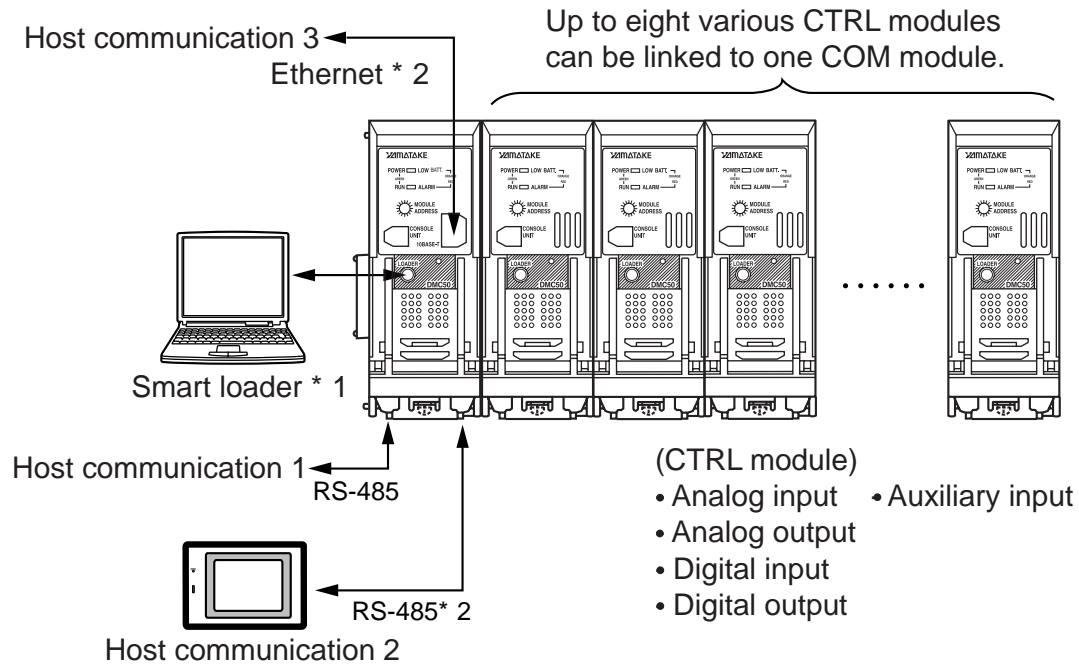

* 1 As a setup tool, SLP-D50 specially designed for DMC50 is available on PCs. SLP-D50 can also be connected through the host communication.

* 2 ME20X module only

● CTRL module is used alone.

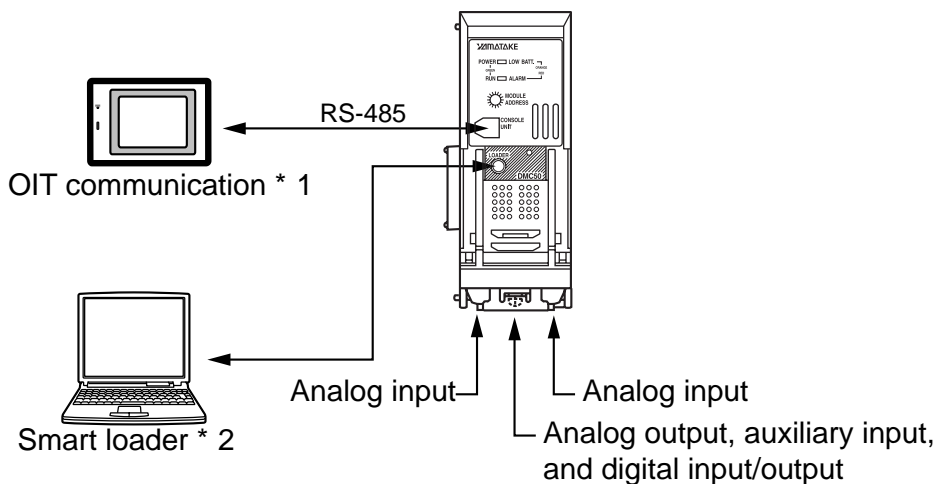

* 1 In this case, the maximum communication distance is 10 m. A modular jack is used as a connector. When the OIT(Operator Interface Terminal) communication is executed, the smart loader communication cannot be performed. When using the smart loader, the cable for the operator interface terminal (modular plug) must be unplugged.

* 2 As a setup tool, SLP-D50 specially designed for DMC50 is available on PCs.

Chapter 2. NAMES AND FUNCTIONS OF PARTS

■ Body and base

● Standard base type

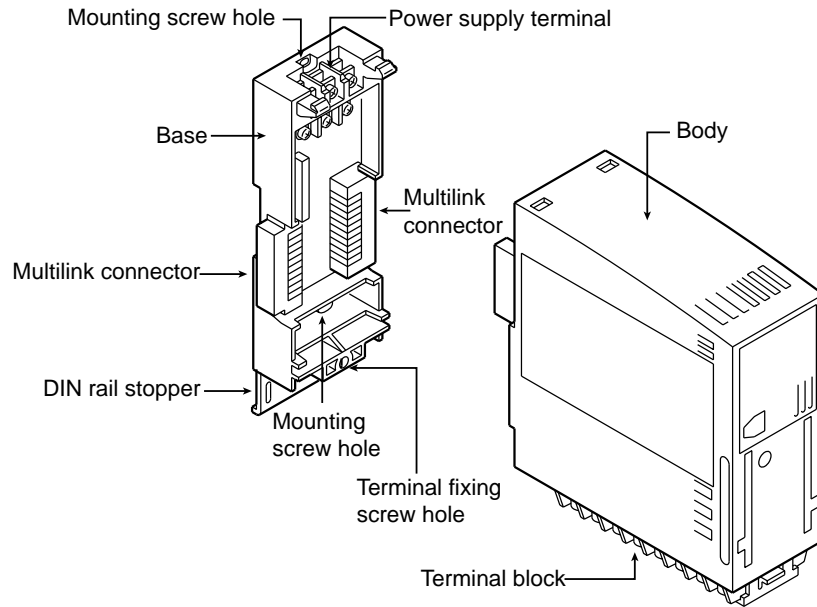

● Extension base type

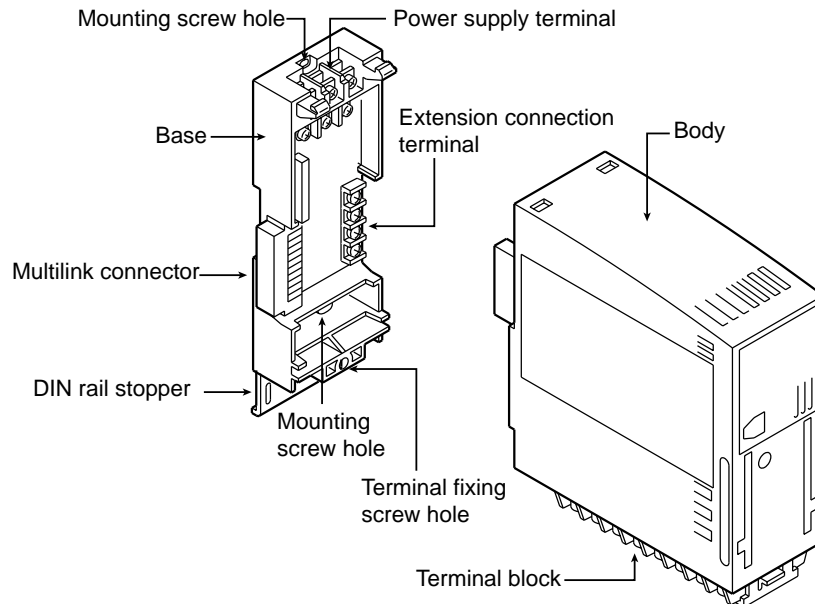

■ Terminal block

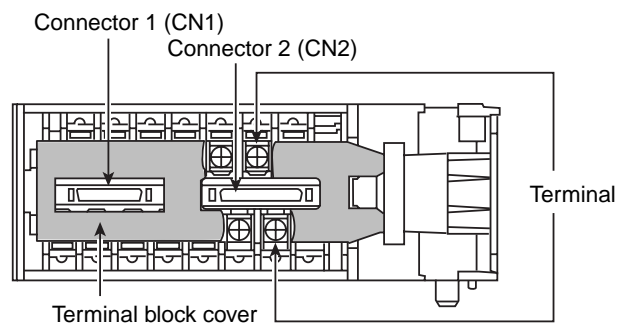

■ Front view

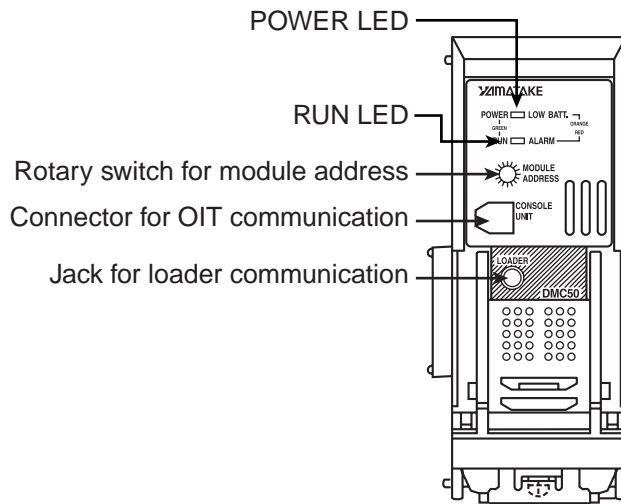

Input / output configuration of CTRL module

● CH40X/CS40X module

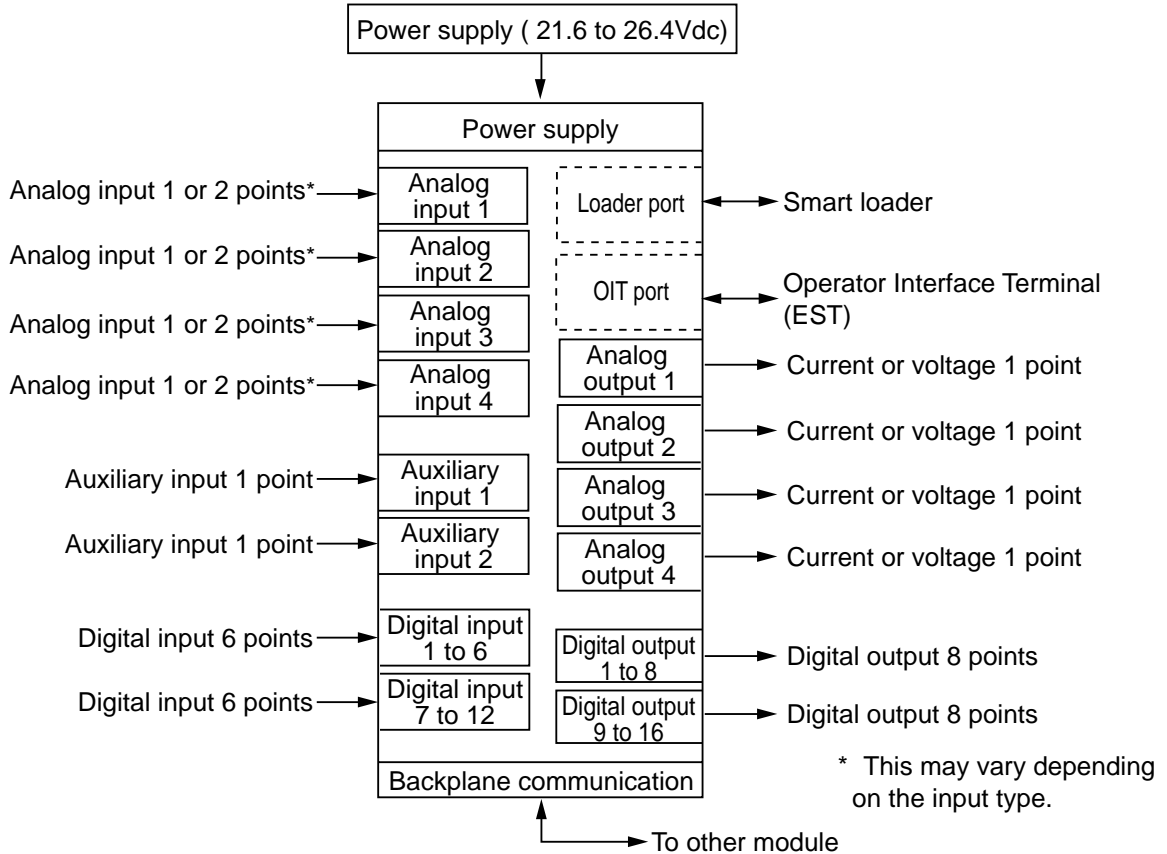

● CH20X/CS20X module

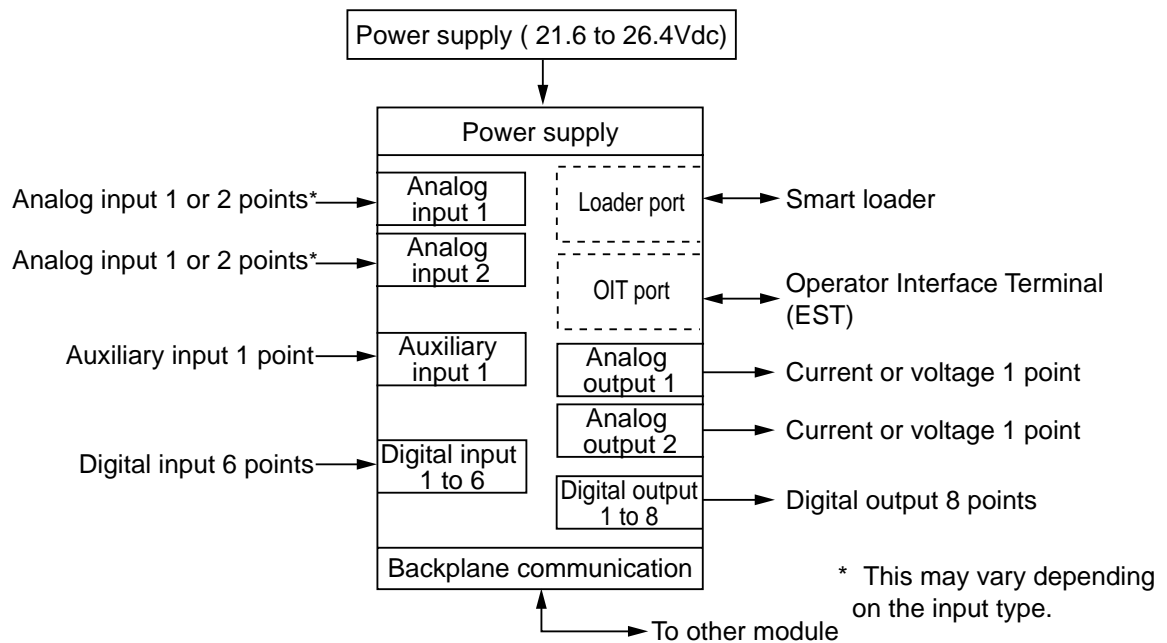

■ LED indications

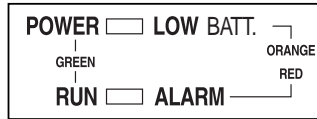

LED		Operation status
POWER	OFF	Power is not supplied.
	Lit in green	Power is supplied and the voltage of the built-in lithium battery is correct.
	Lit in orange	Power is supplied and the voltage of the built-in lithium battery drops.
	Flashing in orange	The rotary switch is set at "0". After the power has been turned ON, this LED flashes for approximately 5 sec., and then it is lit in green or orange.
RUN	OFF	The application program is inactive without error.
	Lit in green	The application program is operating in the real time mode without error.
	Lit in orange	The application program is operating in Cycle to cycle mode without error. (Cycle to cycle mode is a special mode intended to debug the application program.)
	Flashing in red	An error occurs.

■ Rotary switch



Relevant module address (address to identify the linked CTRL module) is set using this rotary switch.

Set a module address ranging from 1 to F.

! Handling Precautions

- Do not set the rotary switch to "0".
- Set the rotary switch properly. If the rotary switch is set to an incorrect position, such as that between two numbers, it is not possible to correctly communicate with the loader or other devices.
- Assign an unique address to each of the modules linked with multilink connectors and / or extension cables.

■ Analog input types

● CH40X / 20X module

- RTD

Input type	Code	Range No.	Range (°C)
Pt100	F50	21	-200.0 to +500.0
Pt100	F31	22	-60.00 to +100.00

- Thermocouple

Input type	Code	Range No.	Range (°C)
K(CA)	K29	1	-200.00 to +1200.00
K(CA)	K24	2	-200.00 to +400.00
E(CRC)	E08	3	0.00 to 800.00
J(IC)	J08	4	0.00 to 800.00
N(Nicr-Ni)	U13	5	0.00 to 1300.00
PLII	Y13	6	0.00 to 1300.00
T(CC)	T44	7	-200.00 to +300.00
B(PR30-6)	B18	8	0.00 to 1800.00
R(PR13)	R16	9	0.00 to 1600.00
S(PR10)	S16	10	0.00 to 1600.00
PR40-20	D19	11	0.00 to 1900.00
W(WRe5-26)	W23	12	0.00 to 2300.00
W(WRe5-26)	W14	13	0.00 to 1400.00
DIN L	Z07	14	-200.00 to +800.00
DIN U	Z08	15	-200.00 to +400.00
Ni-Ni • Mo	Z13	16	0.00 to 1300.00

- Linear voltage

Input type	Code	Range No.	Scaling
-10 to +10mV	L02	40	-99999.9 to +99999.9U
0 to 10mV	M01	41	-99999.9 to +99999.9U
-100 to +100mV	L09	38	-99999.9 to +99999.9U
0 to 100mV	L01	39	-99999.9 to +99999.9U
-1 to +1V	L08	36	-99999.9 to +99999.9U
0 to 1V	L04	37	-99999.9 to +99999.9U
1 to 5V	V01	35	-99999.9 to +99999.9U
0 to 5V	L05	34	-99999.9 to +99999.9U
0 to 10V	L07	33	-99999.9 to +99999.9U

- Linear current

Input type	Code	Range No.	Scaling
0 to 20mA	C08	31	-99999.9 to +99999.9U
4 to 20mA	C01	32	-99999.9 to +99999.9U

● CS40X / 20X module

• RTD

Input type	Code	Range No.	Range (°C)
Pt100	F02	23	16.0000 to 37.0000
Pt100	F35	24	-50.000 to +150.000

• Linear voltage

Input type	Code	Range No.	Scaling
-100 to +100mV	L09	38	-99999.9 to +99999.9U
0 to 100mV	L01	39	-99999.9 to +99999.9U
-1 to +1V	L08	36	-99999.9 to +99999.9U
0 to 1V	L04	37	-99999.9 to +99999.9U
1 to 5V	V01	35	-99999.9 to +99999.9U
0 to 5V	L05	34	-99999.9 to +99999.9U
0 to 10V	L07	33	-99999.9 to +99999.9U

■ Analog output types

Current output : 0 to 20mA_{dc}, 4 to 20mA_{dc}
 Voltage output : 0 to 10V_{dc}
 Time proportional output : 1 to 120s cycle time (Load current setting feature is provided.: 2 to 22 mA_{dc})

■ Auxiliary input types

AC input : 0 to 5Vac, 0 to 6Vac, 0 to 10Vac, 0 to 12Vac
 DC input : 1 to 5V_{dc}

■ Digital input types

± 24V_{dc} input
 6 points (2-loop type) / 12 points (4-loop type)

■ Digital output types

12 to 24 V_{dc}, transistor output (open drain FET output)
 8 points (2-loop type) / 16 points (4-loop type)

■ Communication types

Communication path	Port name / Communication H / W	Protocol	Connection method
OIT communication	OIT port / RS-485 compatible port (3-wire)	CPL	Modular jack
Loader communication	Loader communication port / CMOS	Loader	Loader jack

Chapter 3. INSTALLATION

WARNING



Do not touch any terminals or metal parts connected to the DMC50 when mounting or dismounting this module. Doing so might cause electric shock.



Do not disassemble the DMC50. Doing so might cause electric shock or faulty operation.

CAUTION



Use the DMC50 within the operating ranges recommended in the specifications (temperature, humidity, voltage, vibration, shock, mounting direction, atmosphere, etc.). Failure to do so might cause fire or faulty operation.



Do not block ventilation holes. Doing so might cause fire or faulty operation.



Do not allow lead clippings, chips or water to enter the DMC50 case. Doing so might cause fire or faulty operation.

■ Installation place

Always install this module in a place where:

- High temperature, low temperature, high humidity, and low humidity do not exist.
- Corrosive gas, such as sulfured gas does not exist.
- Fine particle dust and oily smoke are minimized.
- Appropriate measures are taken so that it is neither exposed to direct sunlight, wind, nor rain.
- Mechanical vibration and impact are minimized.
- It is neither close to an electrical noise producing source, a place under the high-voltage cables, nor a welding machine.
- It is 15m or more far away from a high-voltage ignition equipment, such as boiler.
- Effects of high magnetic field are minimized.
- Flammable fluid or steam does not exist.
- Heat produced by a heating element does not adversely affect.

■ Connecting modules

A module can be connected to other modules using the left and right multilink connectors on the base. Connect modules before mounting the modules on the DIN rail or the panel.

As modules are connected, the power supply of each module is connected. This might eliminate the power supply wiring.

■ Mounting

⚠ WARNING



Remove all protective seals from this module before putting this module into service. Failure to do so may cause the faulty operation of this module itself or could result in fire due to this module overheating.

There are two mounting methods, panel mounting and DIN rail mounting. Select an appropriate method suitable for the equipment to be used.

The mounting posture allowed is only the mounting of this module on the vertical panel. It is not allowed to mount this module with its front display panel or terminal part faced upward.

Additionally, to prevent dust or metallic particles from entering this module through the ventilation holes until the operation is started, cover them with protective seals, when necessary.

To safely mount or unmount this module, a surrounding clearance shown in the following figure must be kept:

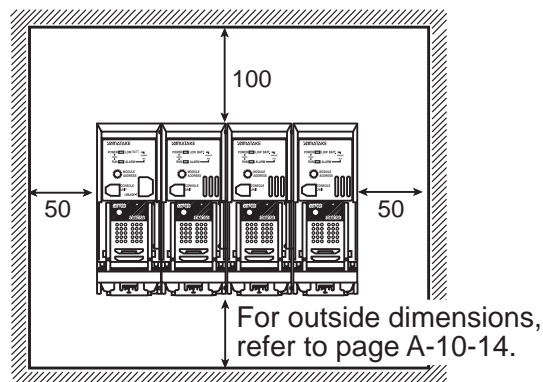

Unit: mm

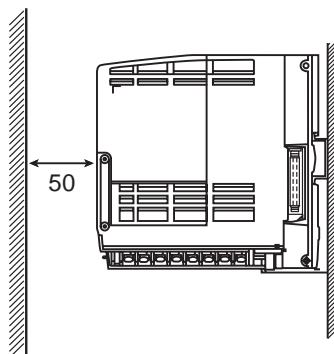

● Removing the body from the base

- (1) Remove the terminal block cover.
- (2) Loosen the terminal block fixing screw.

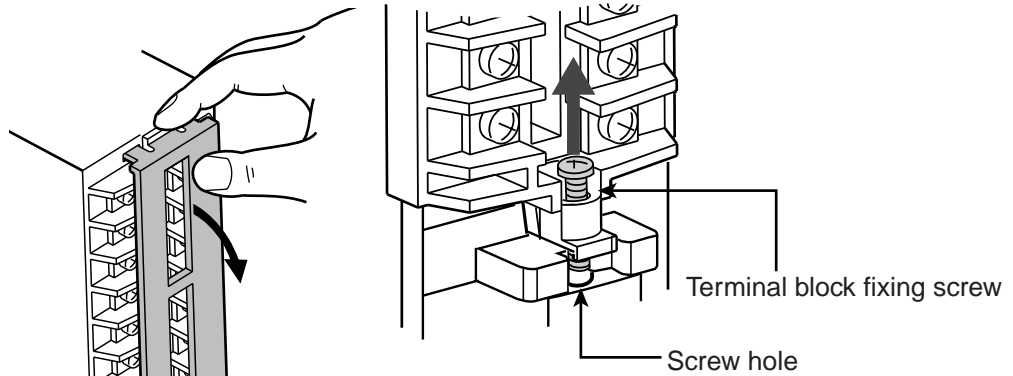

- (3) Raise the body in the direction indicated by an arrow to remove the body from the base.

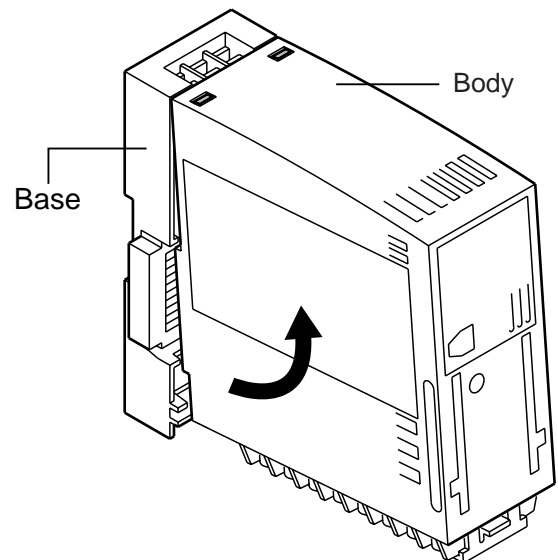

● Panel mounting

Secure the base by tightening the M3 screws through the upper and lower base mounting holes. Here, the screw tightening torque is 1.8 N • m.

Unit : mm

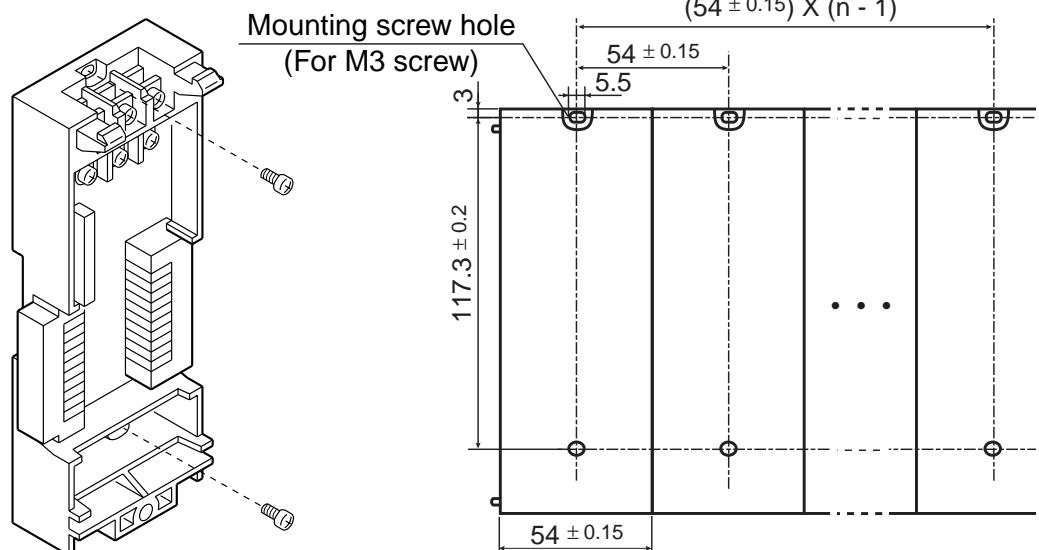

● **DIN rail mounting**

After the DIN rail has been secured, pull out the DIN rail stopper sufficiently until a click sounds, and then hang the base on the rail. Next, push up the DIN rail stopper to lock it. After that, mount the body.

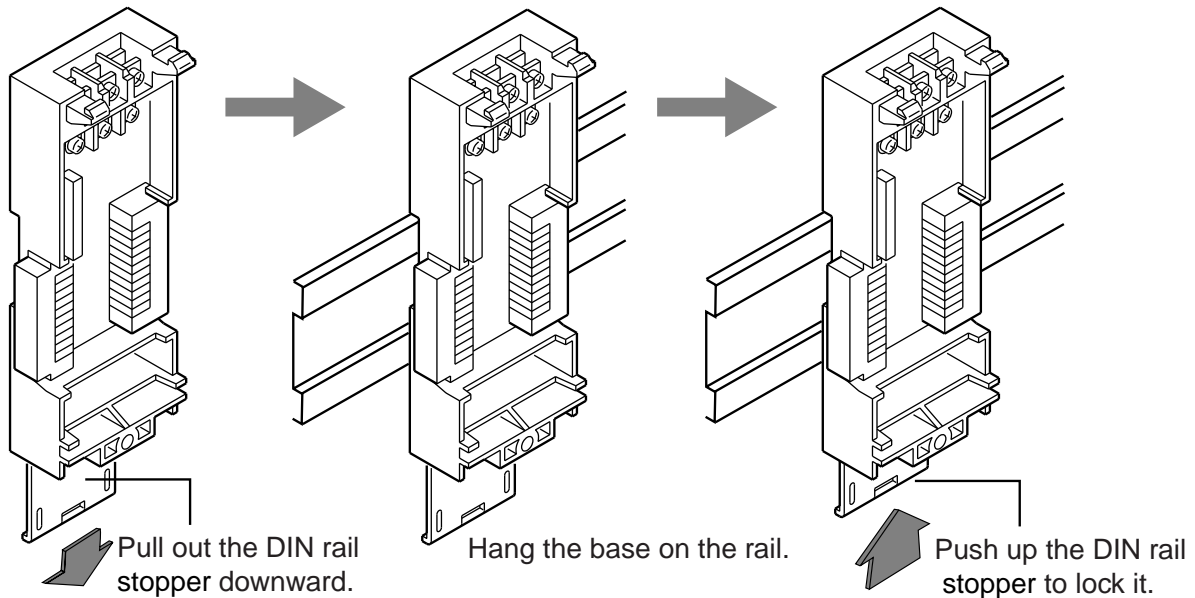

● **Mounting the body to the base**

Fit the hook holes onto the hooks and push the body toward the base until a click sounds.

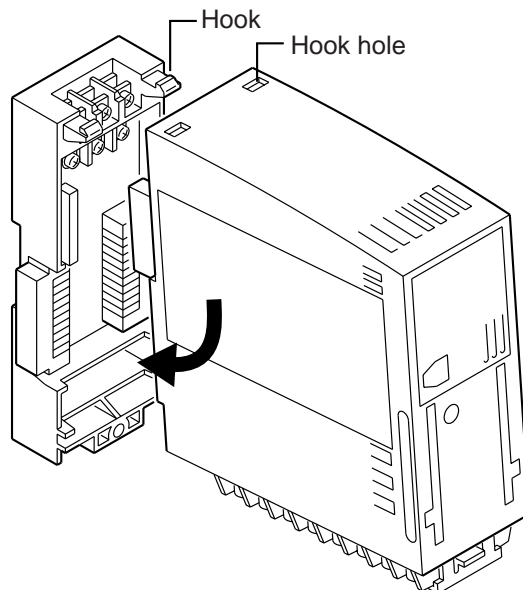

After the wiring to the terminal block has been completed, tighten the terminal block fixing screws firmly, and then attach the terminal block cover.

Chapter 4. WIRING

4 - 1 Wiring precautions

WARNING



Ground the FG terminal with a ground resistance of a maximum of 100 Ω before connecting this module to the measurement target or external control circuits.
Failure to do so might cause electric shock or fire.



Before removing / mounting or wiring the DMC50, be sure to turn the source power OFF.
Doing so might cause electric shock.



Do not touch electrically charged parts such as the power terminals.
Doing so might cause electric shock.

CAUTION



Wire the DMC50 properly according to predetermined standards.
Also wire the DMC50 using designed power leads according to recognized installation methods.
Failure to do so might cause electric shock, fire or faulty operation.



Do not allow lead clippings, chips or water to enter the DMC50 case.
Doing so might cause fire or faulty operation.



Inputs to the current input terminals (2•4, 6•8, 10•12, 14•16) on this module should comply within the electrical current limit stated in the specifications irrespective of the operating conditions of this module.
Failure to do so might cause fire or faulty operation.



Firmly tighten the terminal screws and mounting screws at the torque listed in the specifications.
Insufficient tightening of terminal screws might cause electric shock or fire.



Do not use unused terminals on the DMC50 as relay terminals.
Doing so might cause electric shock, fire or faulty operation.





We recommend attaching the terminal cover after wiring the DMC50.
Failure to do so might cause electric shock.

Handling Precautions

- This module is not equipped with the power switch and protective fuse. When necessary, prepare such parts outside this module. For the controller power wiring, install a main power shutdown switch in an area where the operator can operate it easily.
- Before starting wiring, always check the controller models and terminal Nos. on the wiring diagram label attached to the side panel of the body.
- Keep the input signal lines and communication lines 50 cm or more away from power distribution lines, motor power cables and power supply lines having a voltage of 100V or more to eliminate adverse effects.
- Pay special attention so that no crimp terminals used for the terminal wiring are in contact with adjacent terminals.

■ Wiring diagram labels

The following shows the meanings of the symbols used in the wiring diagram labels attached to the side panels of this module:

-  Grounding terminal
-  Electric shock hazard
-  Warning/ Caution

● Right side panel (Common to CH40X / 20X and CS40X / 20X modules)

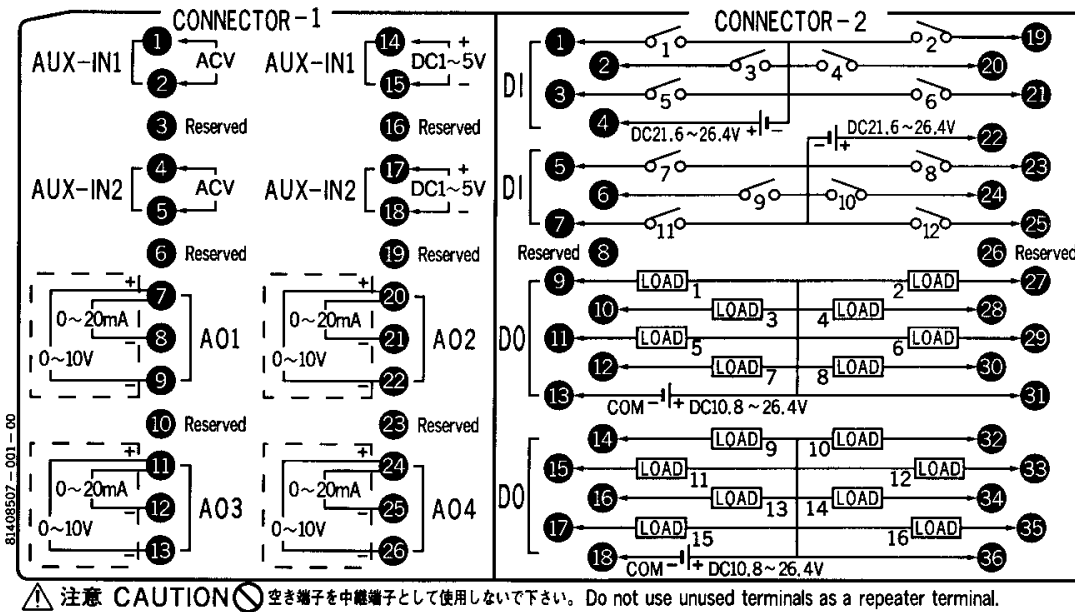

● Left side panel (CH40X / 20X module)

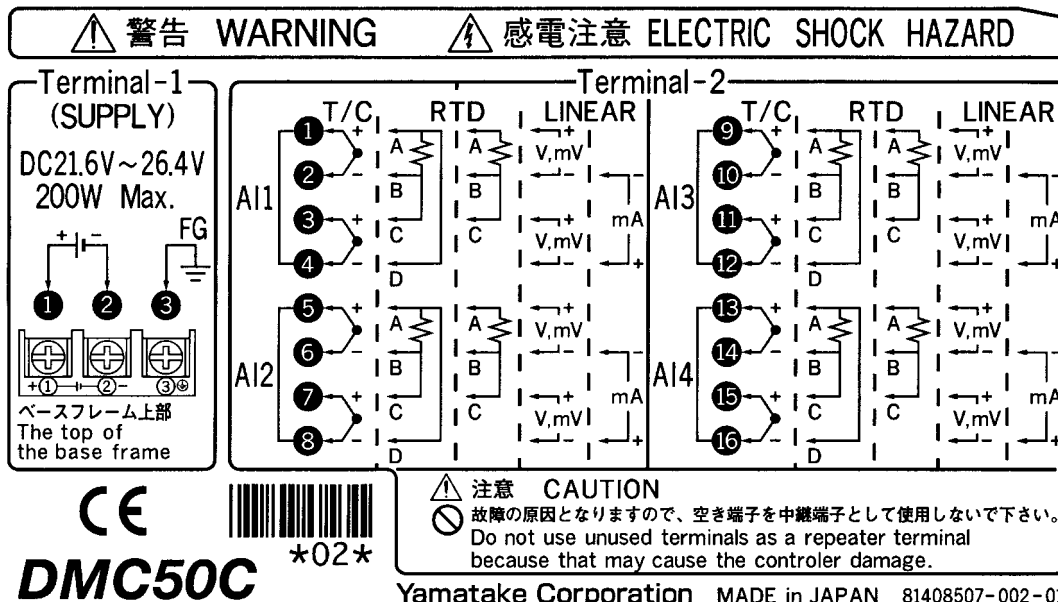

CE
DMC50C
02

Yamatate Corporation MADE in JAPAN 81408507-002-01

● Left side panel (CS40X / 20X module)

⚠ 警告 WARNING
⚠ 感電注意 ELECTRIC SHOCK HAZARD

Terminal-1 (SUPPLY)

DC21.6V~26.4V
200W Max.

① ② ③

+ - FG

+① -② ⊕③

ベースフレーム上部
The top of the base frame

Terminal-2

	RTD	LINEAR	
AI1	① A	← - V,mV → +	← - V,mV → +
	② B		
	③ C		
	④ D		
AI2	⑤ A	← - V,mV → +	← - V,mV → +
	⑥ B		
	⑦ C		
	⑧ D		
AI3	⑨ A	← - V,mV → +	← - V,mV → +
	⑩ B		
	⑪ C		
	⑫ D		
AI4	⑬ A	← - V,mV → +	← - V,mV → +
	⑭ B		
	⑮ C		
	⑯ D		

CE

DMC50CS

03

⚠ 注意 CAUTION

故障の原因となりますので、空き端子を中継端子として使用しないで下さい。
Do not use unused terminals as a repeater terminal because that may cause the controller damage.

Yamatate Corporation MADE in JAPAN 81408507-003-01

4 - 2 Connections

⚠ CAUTION



Firmly tighten the terminal screws and mounting screw at the torque listed in the specifications.

Insufficient tightening of terminal screws might cause electric shock or fire.



Do not use unused terminals on the DMC50 as relay terminals.

Doing so might cause electric shock, fire or faulty operation.



We recommend attaching the terminal cover after wiring the DMC50.

Failure to do so might cause electric shock.

Always use an appropriate crimp terminal corresponding to the M3.5 screw.

Unit : mm

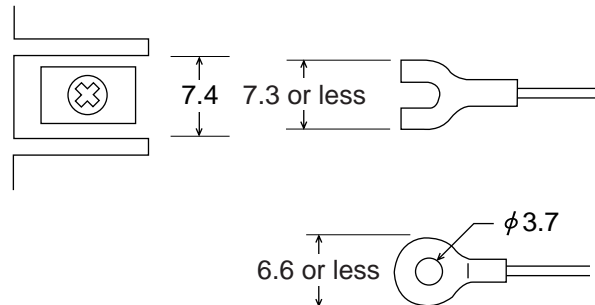

Terminal screw tightening torque is 0.78 to 0.98 N • m.

ⓘ Handling Precautions

- When installing this module in a place where the vibration or impact is large, always use appropriate crimp ring terminals so that wires do not come loose from the connection terminals.
- Pay special attention so that no crimp terminals are in contact with adjacent terminals.

■ Connecting the power supply

Connect the power supply terminals as shown in the following:

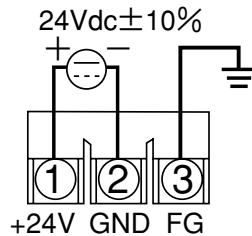

! Handling Precautions

- Connect an appropriate DC power supply with less switching noise to this module so that adverse effects of the noise are minimized. Failure to do so might cause the module to malfunction or the analog input to fluctuate.
- Always ground the FG terminal of the DC power supply properly. Failure to do so might cause the module to malfunction or the analog input to fluctuate.
- If the noise produced by the power supply is large, it is recommended to add an appropriate isolation transformer to the primary side of the DC power supply and to put a line filter for the DC power supply between this module and DC power supply.
- Do not bundle the power cable and grounding cable of this module together with power distribution lines or motor power cables, and do not put the power cable and grounding cable together with power distribution lines or motor power cables in the same wiring conduit or duct.
- Perform the wiring so that the length of the power cable is 30 m or less.
- The power line is mutually connected between modules connected by multilink connectors. Therefore, connect the power supply to only one module. This will supply the electric power to all modules. Do not connect the power supply to multiple modules or do not connect multiple power supplies to one module. Doing so might cause a malfunction.
- The power line between modules linked with the extension cable is not connected. Therefore, connect the power supply to each set of connected modules.

Examples of power supply connections

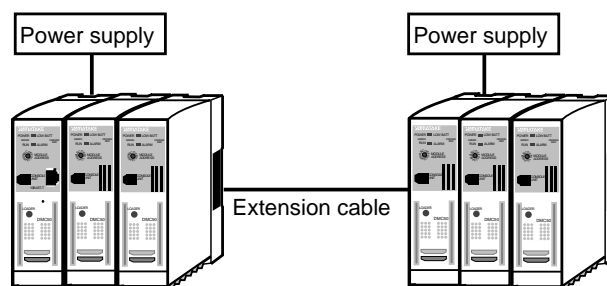

■ Grounding

Ground the FG terminal of this module properly.

Grounding resistance : 100Ω or less

Grounding cable : Annealed copper wire with a cross sectional area of 2 mm² (AWG14)

Length of grounding wire : 20 m max.

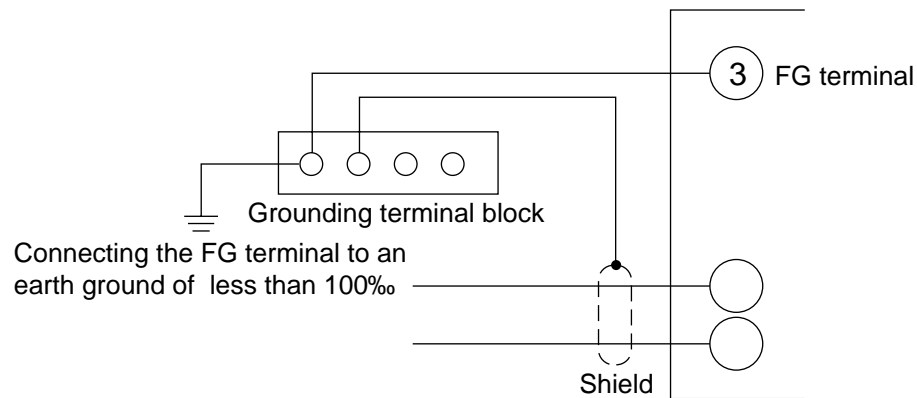

! Handling Precautions

- If it is difficult to ground the shielded cable, prepare a separate grounding terminal block (or earth bar).
- Do not connect the FG terminal of this module to the FG terminal of other instruments.
- The FG terminals are mutually connected between connected modules. Therefore, if only one module is grounded, all connected modules are grounded. Therefore, it is not necessary to connect the grounding cable to each module.
- The FG terminals between modules linked with the extension cable are not connected. Therefore, connect the grounding cable to each set of connected modules.

■ Connecting wires to the terminal block

To connect wires to input terminals, always use an appropriate crimp terminal corresponding to the M3.5 screw.

! Handling Precautions

- When installing this module in a place where the vibration or impact is large, always use appropriate crimp ring terminals so that wires do not come loose from the connection terminals.
- Pay special attention so that no crimp terminals are in contact with adjacent terminals.

The terminal block is located at the lower portion of this module. However, the terminal block is designed to be movable to improve the wiring workability.

- (1) Put your finger on the terminal cover and pull the cover in the direction as shown in the Figure to remove it.
- (2) Loosen the terminal block fixing screw until it is removed from the screw hole.

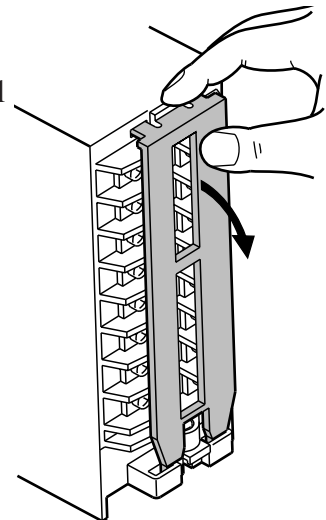

! Handling Precaution

Do not remove the terminal block fixing screw completely, but only loosen it.

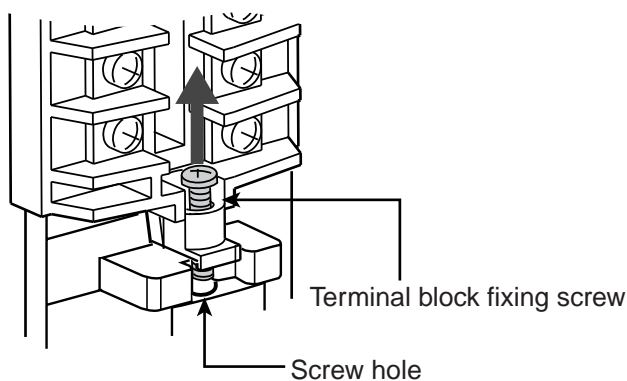

- (3) Pull the hook of the terminal block fixing screw part and pull out the terminal block in the direction indicated by an arrow.

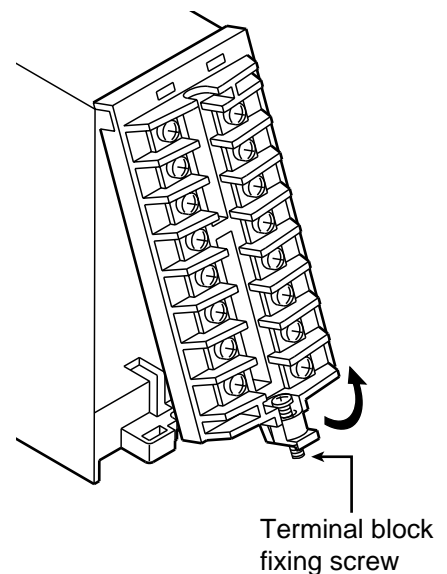

-
- (4) With the terminal block kept opened 90°, slide the terminal block in the slide grooves along with the front panel.

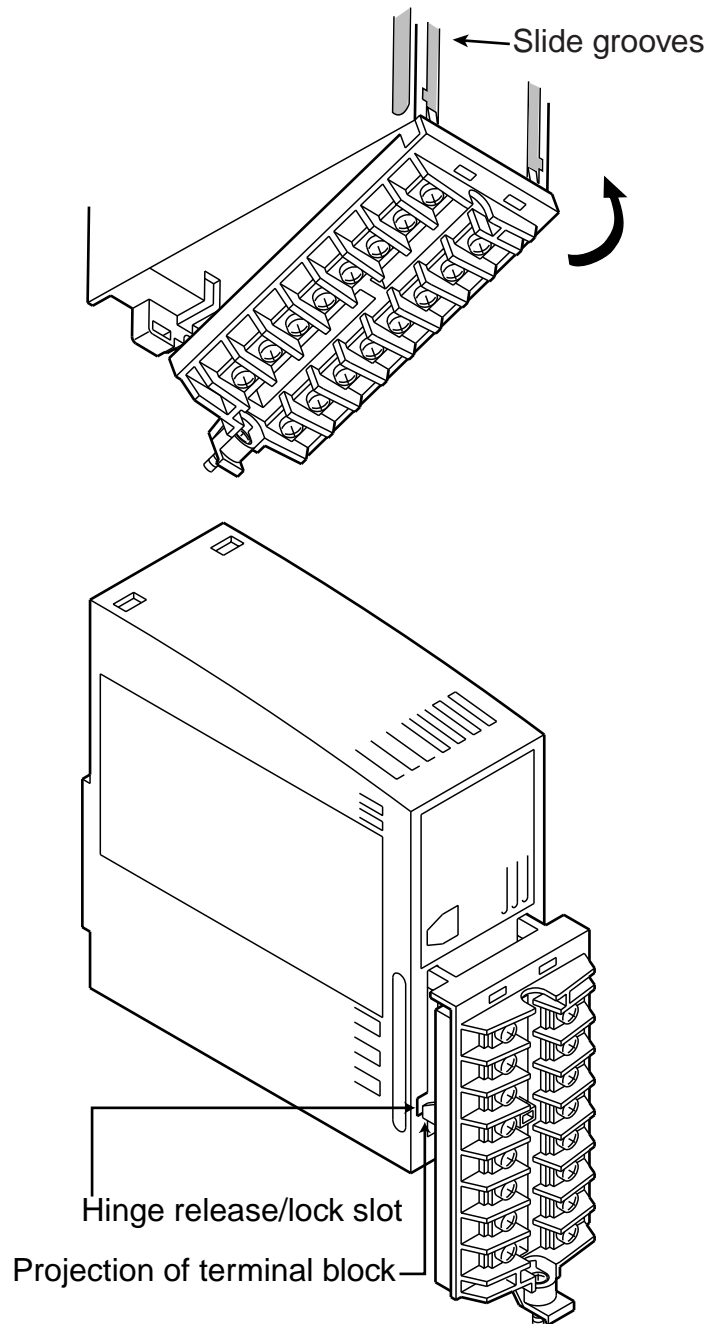

- (5) Connect the wires in this position.
- (6) After the wires have been connected completely, return the terminal block to its original position in the reverse order of above steps and tighten the terminal block fixing screw.

■ Connecting connectors

Connector 1 (CN1) and connector 2 (CN2) are located at the bottom of this module. After wires have been connected to the terminal block, connect the connectors.

Applicable connectors

Connector 1 (CN1)

: TX20A-26PH1-D2P1-D1
(Made by Japan Aviation Electronics Industry, Ltd.)

Connector 2 (CN2)

: TX20A-36PH1-D2P1-D1
(Made by Japan Aviation Electronics Industry, Ltd.)

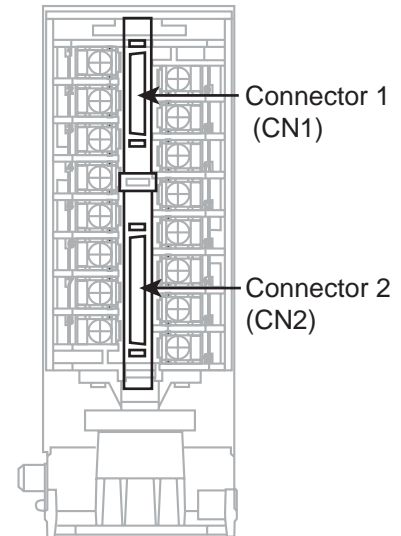

■ Connecting the loader

This module uses smart loader package SLP-D50, which runs on a personal computer, as a loader. To connect to a personal computer, use the jack for the loader communication on the front display panel. To connect to a personal computer, use the loader cable (model 81440793-001).

Jack for loader communication



■ Linking modules

Up to eight CTRL modules can be linked to one COM module. Once the power supply is connected to one module, the electric power is supplied to all the modules linked with multilink connectors. Furthermore, it is also possible to link the modules with the extension cable.

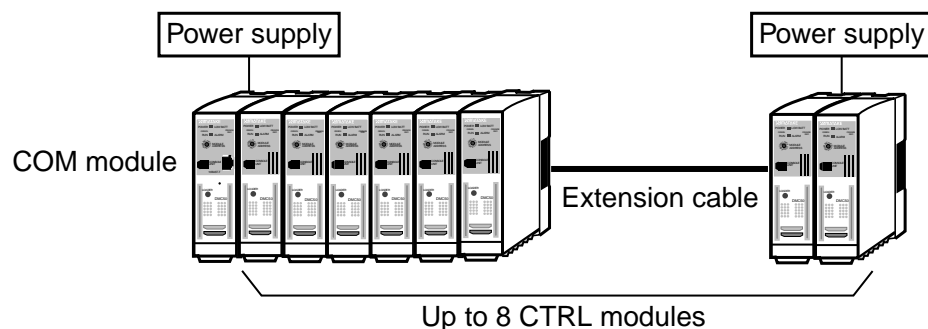

! Handling Precautions

- Insert the multilink connector used for connecting the bases firmly.
- To link the modules with the extension cable, use an extension base. In this case, the power line is not connected. Therefore, separate power supply wiring is required.

■ Connecting with the extension base

Make the link with the extension base as shown in the figure below.
To link the extension bases, use a shielded twist pair cable.

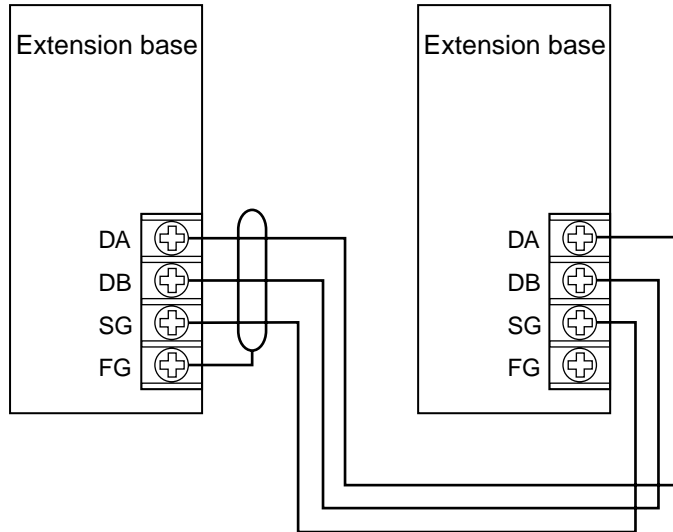

! Handling Precautions

- Perform the wiring so that the length of the extension cable is less than 20 m.
- Do not ground the FG terminals at both ends of the shielded extension cable. Ground only one FG terminal.

■ Operator Interface Terminal(OIT) communication

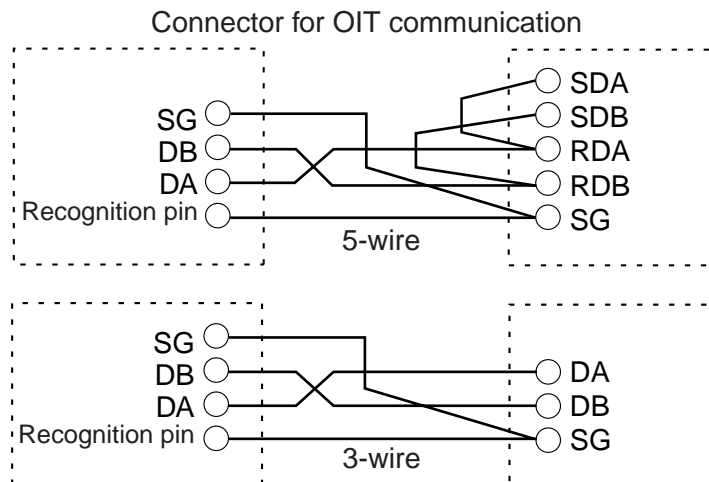
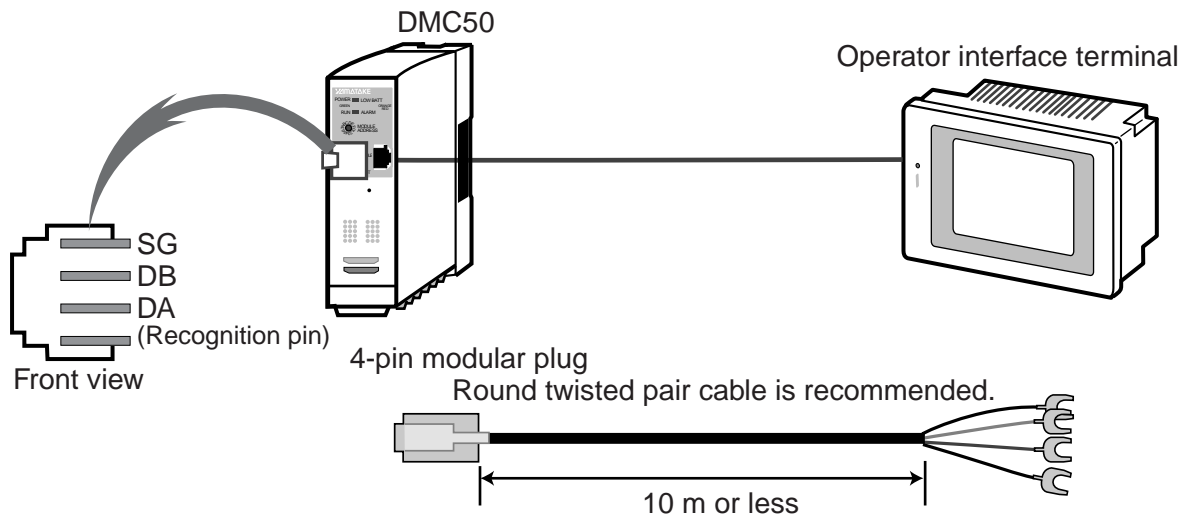

! Handling Precautions

- If the recognition pin is not connected to SG, the communication cannot be performed.
- When using the smart loader, plug out the modular plug.
- The OIT(Operator Interface Terminal) communication via the OIT port is not available in multi drop configurations. If connected in multidrop configuration, a communication error might occur.

■ Connecting analog inputs

The analog input is a universal input corresponding to various sensors. Connect analog inputs corresponding to the sensors as shown in the following:

CH40X / 20X module

Analog inputs 1 to 4

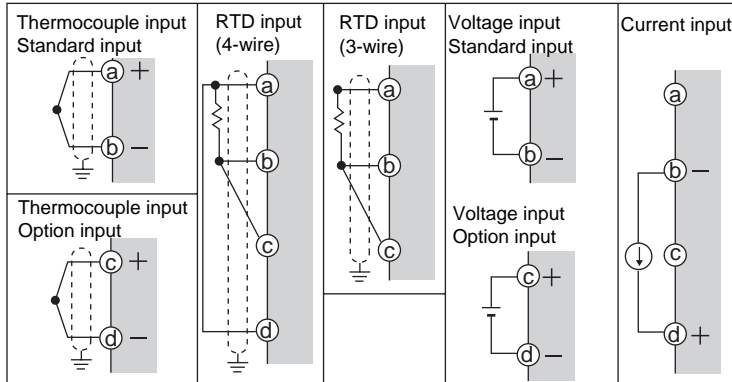

CS40X / 20X module

Analog inputs 1 to 4

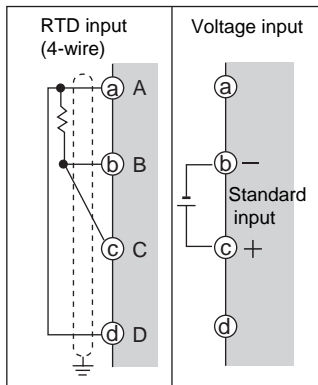

(Front side)

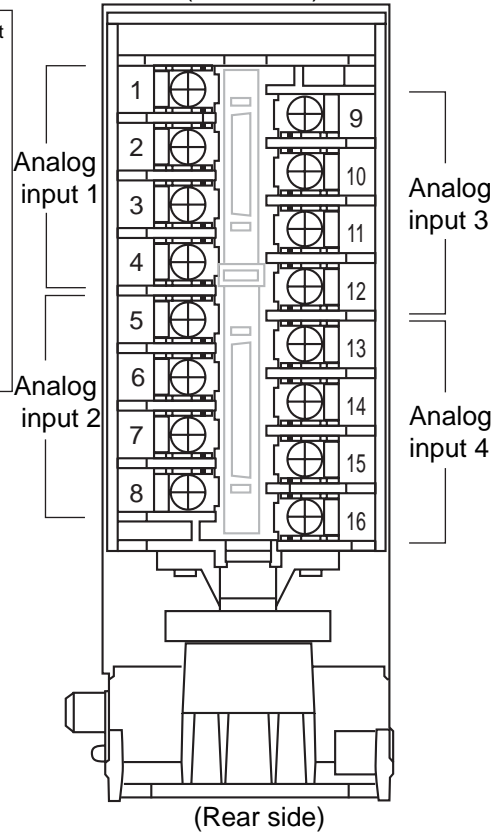

(Rear side)

Terminal No	Function	Terminal No	Function
Analog input 1	1 Analog input channel 1 a terminal	Analog input 3	9 Analog input channel 3 a terminal
	2 Analog input channel 1 b terminal		10 Analog input channel 3 b terminal
	3 Analog input channel 1 c terminal		11 Analog input channel 3 c terminal
	4 Analog input channel 1 d terminal		12 Analog input channel 3 d terminal
Analog input 2	5 Analog input channel 2 a terminal	Analog input 4	13 Analog input channel 4 a terminal
	6 Analog input channel 2 b terminal		14 Analog input channel 4 b terminal
	7 Analog input channel 2 c terminal		15 Analog input channel 4 c terminal
	8 Analog input channel 2 d terminal		16 Analog input channel 4 d terminal

Handling Precautions

- If a voltage is applied between the DC current input terminals (between terminals b and d) while this module is being operated, this might cause the module to malfunction.
- When using a DC current input, the input impedance between the DC current input terminals (between terminals b and d) becomes almost infinity in the power OFF state and until the completion of initialization after the power has been turned ON, due to the structure of this module. For this reason, the maximum voltage, which can be output from the transmitter connected to the DC current input, is applied to the DC current input circuit of this module, possibly causing the internal circuit to break.
Therefore, a transmitter connecting to the DC current input must be the one having an output of DC60V or less in the open load condition.
- Always carefully check the input polarities. Failure to do so might cause the module to malfunction.
- Use an appropriate shielded cable for the input wiring. Connect the shield to the grounding line or the terminal b or d (reference potential level of the analog input circuit of the DMC50), to which the input line is connected, while checking a fluctuation in analog input with your measuring equipment.
- When connecting the thermocouple input or DC voltage input to other instrument in parallel, always check the input impedance of other instrument. A sensor break might not be detected depending on the input impedance of other instrument.
- When using a thermocouple for the input, pay special attention so that the body and terminals are not in contact with the wind. Failure to do so might cause an error or a fluctuation in input.
- When connecting the input and / or output (parallel connection for the input) of this module to the input of such as an A / D converter or analog scanner, a fluctuation in data might be read on this module or mating instrument depending on the type of mating instrument.
- The standard input and option input in a same channel are not isolated. Therefore, look carefully so that no sneak circuits occur. In particular, when using a thermocouple, carefully check the isolation between the standard input and option input at the measuring point. Failure to do so might cause an error.
- As the wire diameter of the thermocouple becomes thinner, the resistance value is larger. Care should be taken if burnout detection is enabled and thin thermocouple is used for long wiring.

■ Connecting analog outputs

For analog outputs, the current output (including the time proportional current output) or voltage output can be selected.

Connect the analog outputs corresponding to the output types as shown in the following:

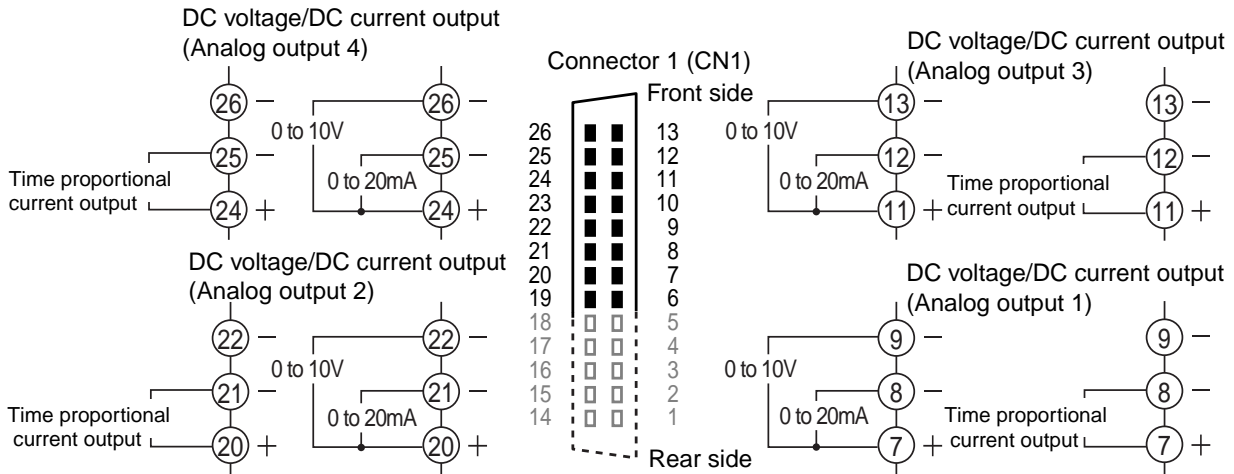

Pin No	Connection	Pin No	Connection
26	Analog output channel 4:0 to 10V (-)	13	Analog output channel 3:0 to 10V (-)
25	Analog output channel 4:0 to 20 mA (-)	12	Analog output channel 3:0 to 20 mA (-)
24	Analog output channel 4:Common (+)	11	Analog output channel 3:Common (+)
23	NC (Unused)	10	NC (Unused)
22	Analog output channel 2:0 to 10V (-)	9	Analog output channel 1:0 to 10V (-)
21	Analog output channel 2:0 to 20 mA (-)	8	Analog output channel 1:0 to 20 mA (-)
20	Analog output channel 2:Common (+)	7	Analog output channel 1:Common (+)
19	NC (Unused)	6	NC (Unused)

! Handling Precaution

Connect the time proportional current output in the same manner as described for the current output.

■ Connecting auxiliary inputs

For auxiliary inputs, AC input (0 to 5Vac, 0 to 6Vac, 0 to 10Vac, 0 to 12Vac) and DC input (1 to 5Vdc) can be selected.

Connect the auxiliary inputs corresponding to the input types as shown in the following:

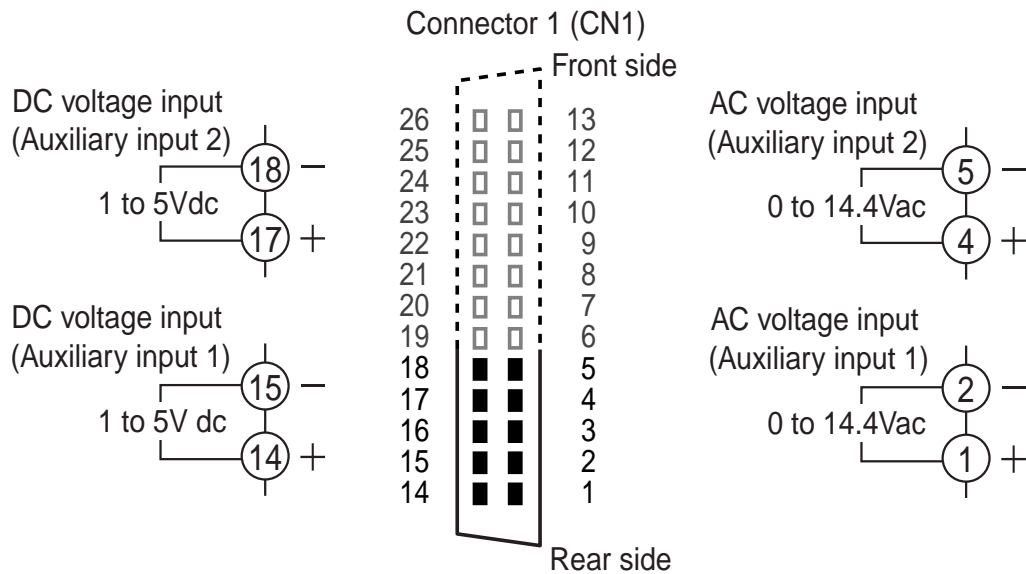

Pin No	Connection	Pin No	Connection
18	Auxiliary input channel 2: DC (-)	5	Auxiliary input channel 2: AC (-)
17	Auxiliary input channel 2: DC (+)	4	Auxiliary input channel 2: AC (+)
16	NC (Unused)	3	NC (Unused)
15	Auxiliary input channel 1: DC (-)	2	Auxiliary input channel 1: AC (-)
14	Auxiliary input channel 1: DC (+)	1	Auxiliary input channel 1: AC (+)

■ Connecting digital inputs / outputs

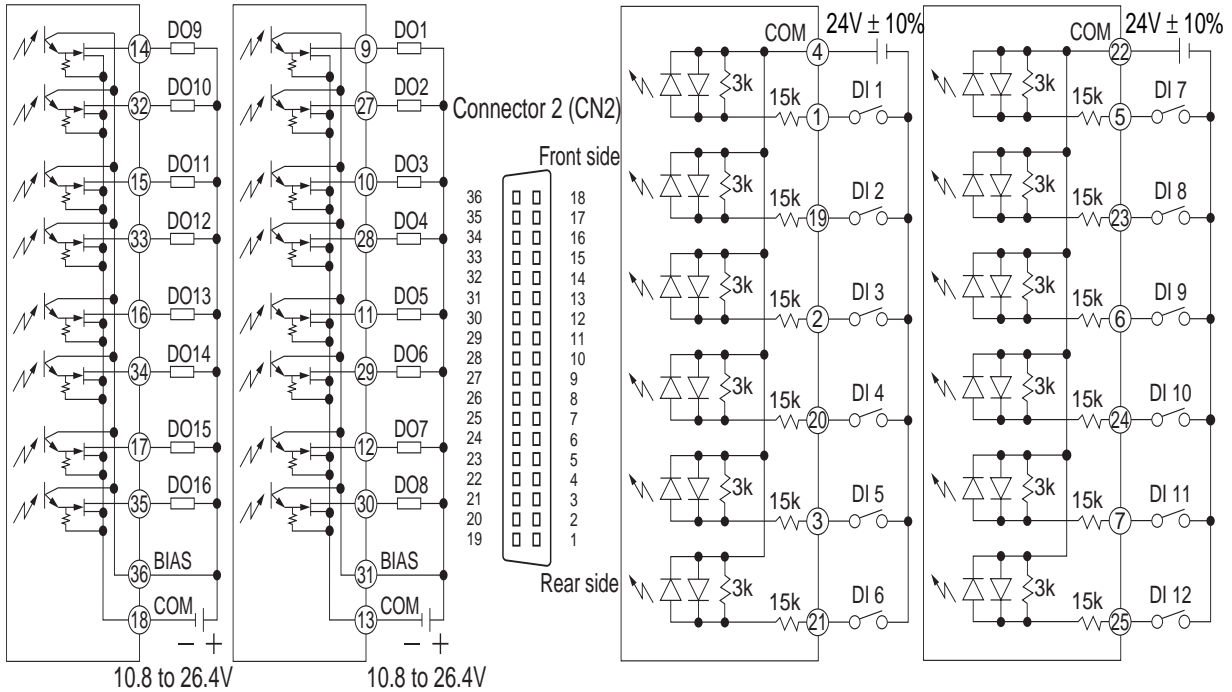

	Pin No.	Connection	Pin No.	Connection
Digital outputs	36	Digital output 9 to 16 BIAS (+)	18	Digital output 9 to 16 Common (-)
	35	Digital output 16	17	Digital output 15
	34	Digital output 14	16	Digital output 13
	33	Digital output 12	15	Digital output 11
	32	Digital output 10	14	Digital output 9
	31	Digital output 1 to 8 BIAS (+)	13	Digital output 1 to 8 Common (-)
	30	Digital output 8	12	Digital output 7
	29	Digital output 6	11	Digital output 5
	28	Digital output 4	10	Digital output 3
		27	Digital output 2	9
	26	NC (Unused)	8	NC (Unused)
Digital inputs	25	Digital input 12	7	Digital input 11
	24	Digital input 10	6	Digital input 9
	23	Digital input 8	5	Digital input 7
	22	Digital input 7 to 12 Common	4	Digital input 1 to 6 Common
	21	Digital input 6	3	Digital input 5
	20	Digital input 4	2	Digital input 3
	19	Digital input 2	1	Digital input 1

■ Recommended cables

For thermocouple inputs, connect the bare thermocouple wires to the terminals of this module. However, if the wiring distance is long or if the thermocouple ends are terminals, wiring is extended with the compensating leads to the terminals of this module.

For inputs and outputs other than the thermocouple, use the JCS-364 shielded polyethylene insulation vinyl sheath cable for instrumentation or its equivalent (so called "twisted shielded cable for instrumentation").

The following cables are recommended:

	2-core	3-core
Fujikura	IPEV-S 0.9mm ² X 1P	ITEV-S 0.9mm ² X 1T
Hitachi Cable	KPEV-S 0.9mm ² X 1P	KTEV-S 0.9mm ² X 1T

If the electromagnetic inductance is relatively small, a shielded multi-core microphone cable JCS-271 can be used.

■ Isolation between input and output

The connections of this module are isolated as shown in the following:

Connection	Number of isolation blocks	
	4-loop type	2-loop type
Analog input	4 (Channel 1,2,3 and 4)	2 (Channel 1 and 2)
Analog output	4 (Channel 1,2,3 and 4)	2 (Channel 1 and 2)
Auxiliary input	2 (Auxiliary input 1 and 2)	1 (Auxiliary input 1)
Digital input	2 (Digital input 1 through 6, 7 through 12)	1 (Digital input 1 through 6)
Digital output	2 (Digital output 1 through 8 9 through 16)	1 (Digital output 1 through 8)
Backplane communication	1	1
Loader port / OIT port	1	1

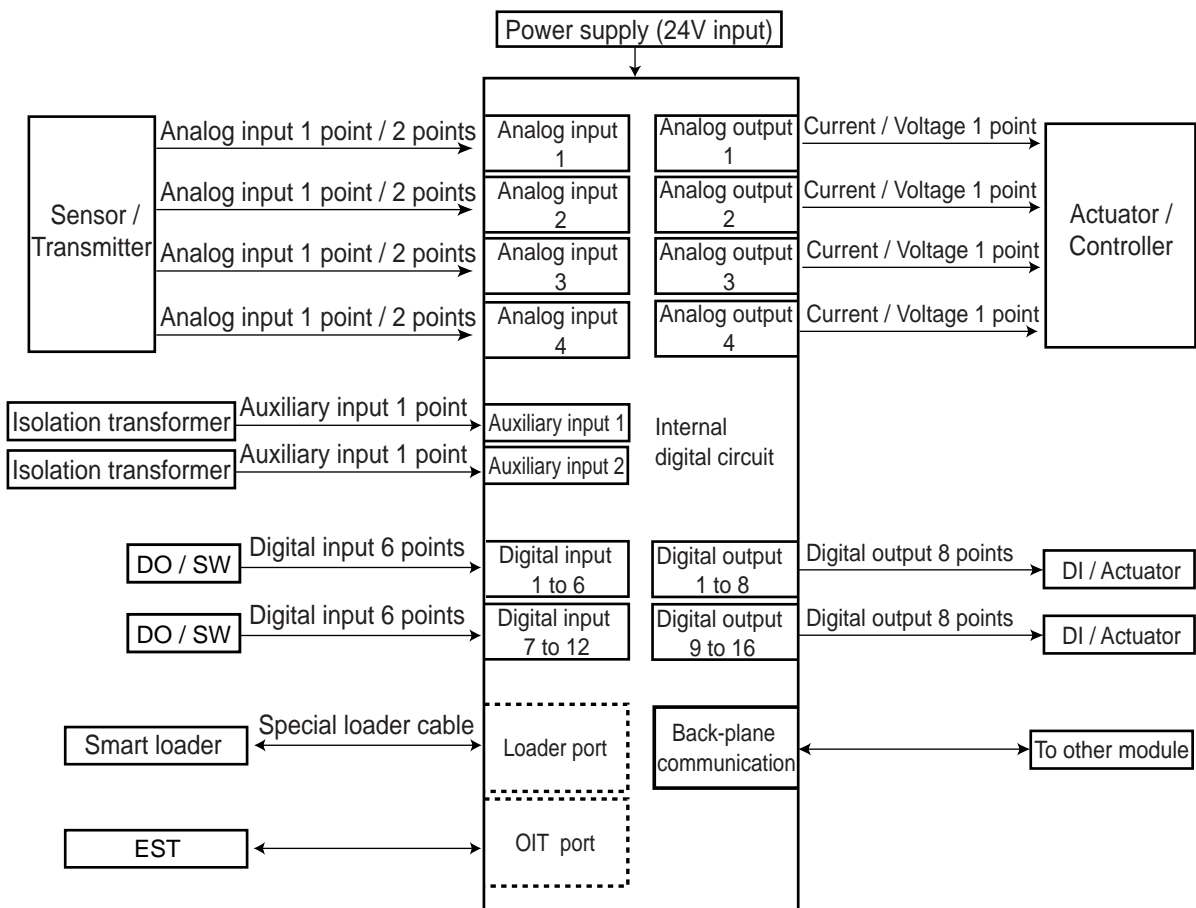

* Portions surrounded by solid lines are isolated from other blocks.

Chapter 5. MODES

5 - 1 Modes of operation

This section describes the modes provided on the CTRL module.
Note that no modes are provided on the COM module.

The CTRL module has the following modes:

The mode is mainly classified into two groups, "Application inactive mode" and "Application operating mode".

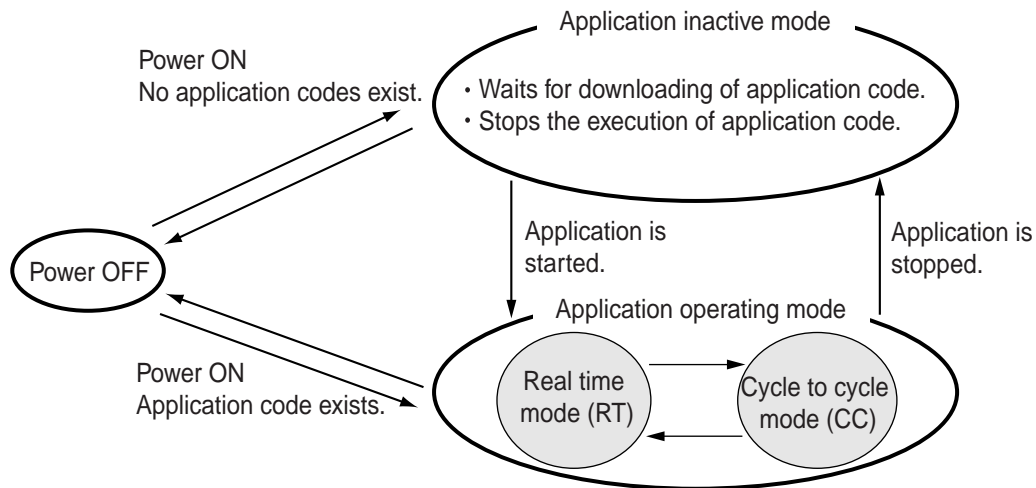

■ Application inactive mode

This Application inactive mode is a mode in which no application code exists on this module, or an application code exists but is not executed.

- The RUN LED on this module is off.
- Application code can be downloaded only in this mode.
- In Application inactive mode, the debugger on the ISaGRAF workbench shows the message, "No Applications".
- When a application code has been downloaded, the operation is started from the Application operating mode when the power is turned ON next time.
- The I / O system of this module gets separated from the execution of the application code, so that the I / O is processed independently.
- The AI, AUX-IN, and DI values can be monitored by the relevant System Monitor Parameters.
- The AO, DO, and TP values can be monitored by the relevant System Monitor Parameters. Additionally, these values can also be altered to desired levels manually.

■ Application operating mode

Application operating mode (hereafter referred to as Operating mode) is a mode in which an application code is executing in this module.

- In Operating mode, the debugger of the ISaGRAF workbench shows the message, "***** active.". (***** is the name of a project made by the user.)
- The I / O of this module performs the process according to the application code.
- The AI, AUX-IN, and DI values can be monitored by the relevant System Monitor Parameters, separating from the I / O variables (input variables) of the ISaGRAF.
- The AO, DO, and TP values can be monitored by the relevant System Monitor Parameters, separating from the I / O variables (output variables) of the ISaGRAF. However, it is not possible to alter such values to desired levels manually. (The AO, DO, and TP values are updated using the application code of the ISaGRAF.)
- When a new application code is downloaded to this module, the mode is automatically transited to Operating mode. In addition, two execution modes "Real time mode (RT)" and "Cycle to cycle mode (CC)" are provided in Operating mode.

● Real time mode

Normally, this mode is used.

In this mode, the cyclic execution is performed at intervals of cycle time (this is also called "cycle timing") set by the user.

- The RUN LED on this module is lit in green.
- The following process is performed in one cycle and executed cyclically:

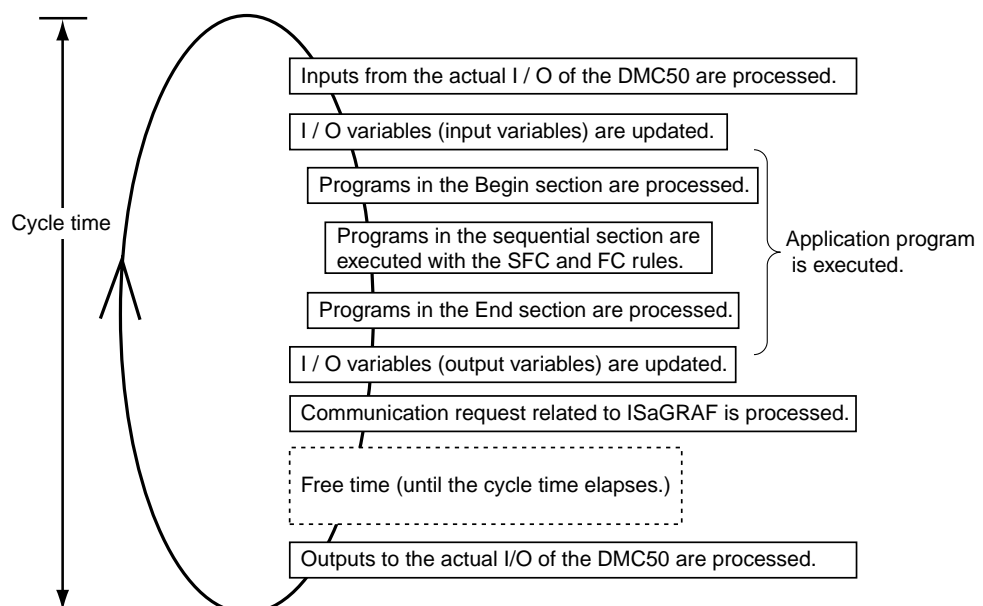

- In the real time mode, the debugger of the ISaGRAF workbench shows the message, "RUN".

● Cycle to cycle mode

Normally, this mode is not used.

- In this mode, the cyclic execution is suspended.
- The RUN LED on this module is lit in orange.
- The application code is not executed cyclically in this mode. However, only the input scanning and the output refreshing are executed cyclically at intervals of cycle time.
- In Cycle to cycle mode, the debugger of the ISaGRAF workbench shows the message, "STOP". Additionally, the "Execute one cycle" command can be sent from the debugger. In this case, the application code can be executed only by one cycle.

❗ Handling Precautions

Cycle to cycle mode is not a mode that the execution is performed cyclically at intervals of cycle time. This mode is intended for debugging.

5 - 2 Mode transitions

■ Mode at power ON

- If no application code exists in this module (application code is not downloaded) or if an application code exists but cannot be executed, the mode becomes the "Application inactive mode".
- When an application code exists in this module, the mode becomes the "Operating mode".

Note

The execution mode (Real time mode / Cycle to cycle mode) when the application is started is decided by the setting of "Application run time options " in the ISaGRAF workbench.

■ Starting of application (From Application inactive mode to Operating mode)

- When any application code exists on this module, the mode is transited to Operating mode by selecting [Start Application] command from the [File] menu in the debugger of the ISaGRAF workbench.
- The mode is also transited to Operating mode by selecting [Start Application] command from the [Online] menu in SLP-D50.
- When a new application code is downloaded to this module, the mode is automatically transited to Operating mode.

■ Stopping of application (From Operating mode to the Application inactive mode)

- The mode is transited to Application inactive mode by selecting [Stop Application] command from the [File] menu in the debugger of the ISaGRAF workbench.
- The mode is also transited to Application inactive mode by selecting [Stop Application] command from the [Online] menu in SLP-D50.

Handling Precautions

- To download a new application code, it is necessary to change the mode to "Application inactive mode".
- Switching the mode between Operating mode and Application inactive mode can be performed only from the ISaGRAF workbench or SLP-D50.

■ Real time mode and Cycle to cycle mode

In Operating mode, the execution mode is transited to a desired mode by selecting [Cycle to cycle / Real time] from the [Control] menu in the debugger of the ISaGRAF workbench.

 **Note**

In Cycle to cycle mode, selecting [Execute one cycle] from the [Control] menu in the debugger of the ISaGRAF workbench performs “Execute one cycle”.

Chapter 6. APPLICATION PROGRAM

6 - 1 About ISaGRAF

For the CTRL module, the user can freely develop desired application programs. The program development environment uses ISaGRAF in conformity with IEC61131-3, a worldwide standard programming language in the control design field.

Handling Precautions

- This chapter describes the ISaGRAF specifications extended for this instrument and cautions necessary to use this instrument.

The user who creates application programs using the ISaGRAF must read this chapter to fully understand its contents.

- Note that this chapter does not include all of information necessary to create application programs.

For further information,

 refer to Smart Loader Package SLP-D50 for Module Type Controller DMC50 User's Manual CP-SP-1122E and "ISaGRAF Version 3.4 User's guide" * .

- * "ISaGRAF Version 3.4 User's guide" in the PDF file format is included in the "ISaGRAF Version 3.4 Workbench" installation CD contained in the SLP-D50 package.

6 - 2 Application program execution

■ Flow of execution

ISaGRAF is a synchronous type system. In Operating mode, an application program is executed so that the cycle time set by the user is the period of one cycle.

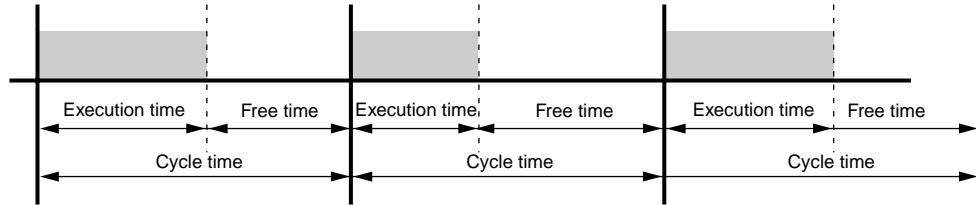

Note

- The cycle time means the time, at which intervals an application program executes periodically. The cycle time is specified in the cycle timing setting of the Application run time options in the ISaGRAF workbench.
- The execution time can be checked using the debugger of the ISaGRAF workbench or SYSTEM function block.
- The free time is used for the communication process or memory error check.

The following shows the flow of the process in a cycle:

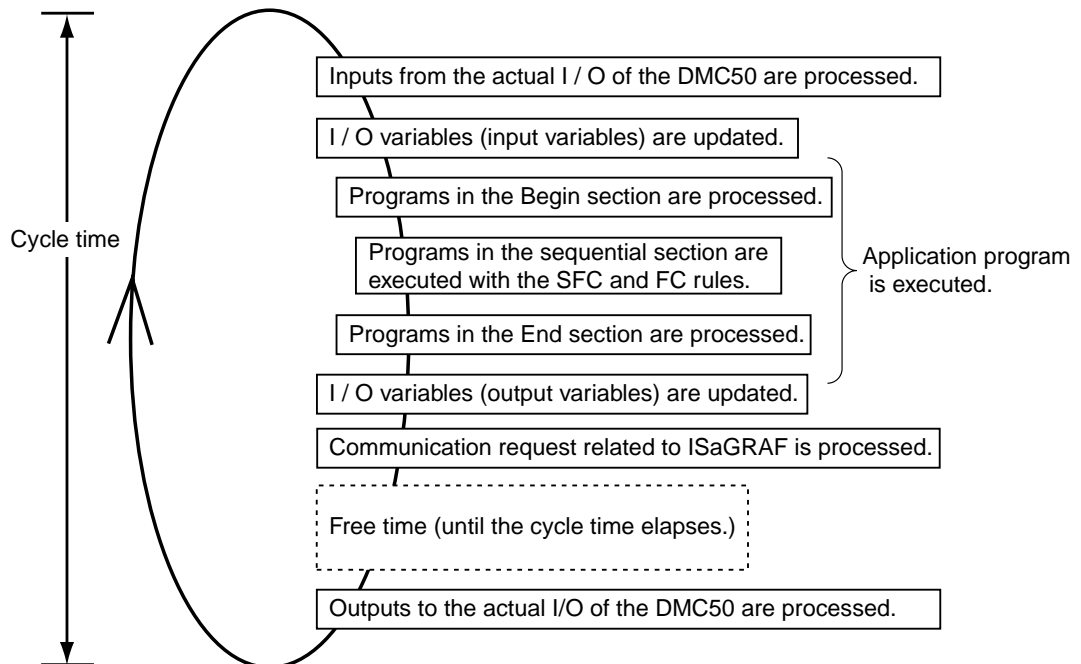

■ Cautions for execution

This section describes the cautions necessary to execute the application program.

● Operation if the execution time exceeds the cycle timing setting.

Even if the execution time of the application program exceeds the cycle timing setting (including that the cycle timing setting is "0"), ISaGRAF continues the process until all the operations in one cycle are completed.

After that, a minimum period of time necessary to execute the communication process is allocated, and the next cycle is executed continuously.

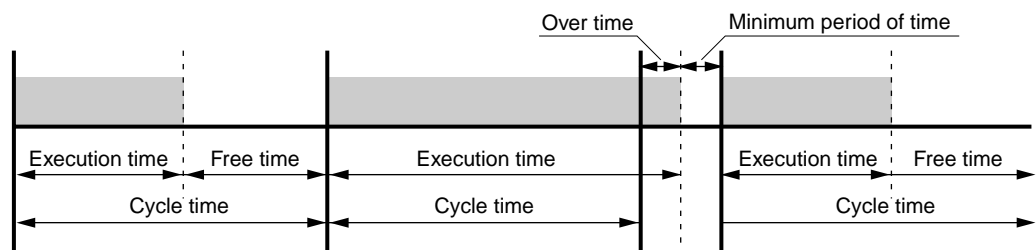

📖 Note

The execution time, maximum execution time, and the number of cycle time overflows can be checked using the debugger of the ISaGRAF workbench or the SYSTEM function block.

● Caution 1 for cycle timing setting

The cycle timing setting range of the ISaGRAF workbench is "0 to 65535 ms".

However, if the cycle timing setting exceeds "1s", a trouble might occur in the communication response. In that case, it is not preferable to continue the process.

In actual examples, when the application needing 1s or longer is executed, the shortest time of the communication response becomes 1s or longer. This might lead to the communication timeout and then can cause improper operation of the system.

● Caution 2 for cycle timing setting (Factor causing fluctuation in execution time)

When determining a cycle time, it is necessary to take worst conditions into consideration.

The following lists the factors that cause a fluctuation in execution time:

- In an application program, a part is executed or is not executed conditionally.
- Analog input type and enable / disable setting status:
Since the execution time includes the time to process the inputs from the actual I / O of the DMC50, the inputs not to be used must be set at "Disabled" using the AI Setup in the System Parameters. Additionally, the thermocouple and RTD ranges need a slightly longer processing time compared to the linear ranges.
- Analog output type setting status:
When using the time proportional output, this needs a slightly longer processing time compared to the current / voltage proportional output (0 to 20 mA, 4 to 20 mA, 0 to 10 V).
- Digital output type setting status:
When using the time proportional output (TP output), this needs a slightly longer time compared to the ON / OFF output (DO output).
- Various initialization processes are activated when executing the application program for the first time. Therefore, the execution time of the 1st cycle tends to be longer.
- If "Communication request related to the ISaGRAF" exists, data for the response is created. Note that this time is also included in the execution time. Communication requests occur when performing the communication through SLP-D50 / ISaGRAF. In particular, when monitoring with the dictionary editor, the execution time becomes long since the data volume is large.

● Changing of cycle time from debugger

After downloading, it is possible to change the cycle time from the debugger. This change is for debugging purpose.

When the power is turned ON again, the operation is started with the cycle timing (value before change) setting in the "Application run-time option" specified before the compilation.

Note that the change from the debugger does not affect the setting.

- **Rotary switch = "0"**

When the power is turned ON with the rotary switch on the front panel of this module set at "0", the mode always becomes Application inactive mode.

Even though the application code is downloaded in this state, the mode is not changed to Operating mode.

Additionally, the mode cannot be transited to Operating mode through the CPL communication.

- ❗ **Handling Precautions**

Even though the rotary switch is changed to "0" in Operating mode, the mode is not changed to Application inactive mode. Additionally, even though the rotary switch is changed to a position other than "0" in Application inactive mode, the mode is not changed to Operating mode.

- **Time until application is started**

When the mode is transited from Application inactive mode to Operating mode or when the mode to Operating mode immediately after the power has been turned ON, strictly observe the following cautions:

When the mode is transited to Operating mode, this module checks the data to determine whether or not the application code is corrupted. This check time may depend on the size of the application code. If the program size is large, it may take approximately 5 to 10s. (This is a period of time until the RUN LED on this module is changed from "off" to "lit in green" (or "lit in orange") after the mode has been changed to Operating mode.)

The communication process is stopped completely during data check. Therefore, if any communication request is issued while the mode is being transited to Operating mode, the communication time-out might occur.

- **Application program executes an endless loop**

If an endless loop is created by mistake or if a process needing extremely long calculation time is written in the application program, the ISaGRAF continues the process until one cycle calculation is completed even though the processing time exceeds the cycle time.

Since the communication process is stopped while the ISaGRAF is processing the operation, it is impossible to transit the mode to Application inactive mode using the host communication facilities.

If the above situation occurs, turn OFF the power, set the rotary switch on the front panel of this module to "0", and then turn ON the power again.

(In this position, the mode is not changed to Operating mode even though any application code exists.)

In this mode, download the properly corrected application code again. After that, return the rotary switch to its previous position, turn OFF the power, and then turn it ON again.

The corrected application program then starts running.

Chapter 7. PARAMETERS

7 - 1 Parameter lists

The following shows the Parameter lists of the CTRL module:

● System Parameters

Type label	Description
AI Setup (High resolution type : for standard inputs)	This setup is only for the high resolution type (CH40X / 20X). The settings related to the standard analog inputs (AI1 to AI4) are made. The range is changed, and the filter and bias are set or changed.
AI Setup (High resolution type : for option inputs)	This setup is only for the high resolution type (CH40X / 20X). The settings related to the option analog inputs (option inputs AI1 to AI4) are made. The range is changed, and the filter and bias are set or changed.
AI Setup (Special type)	This setup is only for the special type (CS40X / 20X). The settings related to the analog inputs (AI1 to AI4) are made. The range is changed, and the filter and bias are set or changed.
AUX-IN Setup	The settings related to the auxiliary inputs (AUX-IN1 to AUX-IN2) are made. The range is changed, and the filter and bias are set or changed.
AO Setup	The settings related to the analog outputs (AO1 to AO4) are made. The output type (0 to 20 mA, 4 to 20 mA, 0 to 10V, and time proportional output) and time proportioning cycle time are set or changed.
DO Setup	The settings related to the digital outputs (DO1 to DO16) are made. When using DO as time proportional output, it is changed using this setup.
TP Setup	The settings related to the TP outputs (TP1 to TP16) are made. When using DO as time proportional output, the details are set or changed using this setup.
Date and Time Setup	The date and time of the built-in real time clock of this module are set.
Front Port Communication Setup	The settings related to the front panel port are made. The transmission speed of the OIT(Operator Interface Terminal) port is changed.

● System Monitor Parameters

Type label	Description
System Alarm Log AI Alarm Log AUX-IN Alarm Log	Up to 16 latest System Alarm, AI Alarm and AUX-IN Alarm generation / reset records can be checked.
H / W Info	The model and ROM revision of this module can be checked.
System Status	The alarm status of this module can be checked. The error status, such as memory error, input error, or battery voltage drop can be checked.
Date and Time Display	The date and time of the built-in real time clock of this module can be checked.
AI Status	The values of the analog inputs (AI1 to AI4) are monitored as values in relevant industrial unit. This data is common to the high resolution type (CH40X / 20X) and the special type (CS40X / 20X).
AUX-IN Status	The values of the auxiliary inputs (AUX-IN1 to AUX-IN2) are monitored as values in % (percentage) for the AC voltage range and as values in relevant industrial unit for the DC voltage range.
AO Status	The values of the analog outputs (AO1 to AO4) are monitored as values in % The value actually output from this module can be checked as a value ranging from 0 to 100%
DI Status	The values of the digital inputs (DI1 to DI12) are monitored. The value (ON / OFF) actually input to this module can be checked.
DO Status	The values of the digital outputs (DO1 to DO16) are monitored. The value (ON / OFF) actually output from this module can be checked.
TP Status	The TP output when using the digital output as time proportional output can be monitored. The values of the TP outputs (TP1 to TP16) are monitored as values in % The value actually output from this module can be checked as a value ranging from 0 to 100%
Zener Barrier Adjustment Counts	This setup is only for the high resolution type (CH40X / 20X). This setup is used to adjust the zener barrier when working with RTD.
Front Port Active Communication Setup	The communication setting actually used for the front port can be checked.
Memory Usage Monitor	The usage and capacity values for the application code or Calculation Parameters can be checked.

● Calculation Parameters

Type label	Description
PID_A Options	This setup is necessary to use the PID_A (standard PID control) function block. The settings necessary for the control calculation, such as control action, PV range, and auto-tuning method are changed.
PID_A Constants	This setup is necessary to use the PID_A (standard PID control) function block. The constants necessary for the control calculation, such as PID constants and output limit values are set and changed.
PID_CAS Options	This setup is necessary to use the PID_CAS (cascade PID control) function block. The settings necessary for the control calculation, such as control action, PV range, and auto-tuning method are changed.
PID_CAS Constants	This setup is necessary to use the PID_CAS (cascade PID control) function block. The constants necessary for the control calculation, such as PID constants and output limit values are set and changed. The constants are individually set on the master and slave sides.
Ra_PID Options	This setup is necessary to use the Ra_PID (RationalLOOP PID control) function block. The settings necessary for the control calculation, such as control action, PV range, and auto-tuning method are changed.
Ra_PID Constants	This setup is necessary to use the Ra_PID (RationalLOOPPID control) function block. The constants necessary for the control calculation, such as PID constants and output limit values are set and changed.
UP_PID Options	This setup is necessary to use the UP_PID (use-point PID control) function block. The settings necessary for the control calculation, such as control action, PV range, and auto-tuning method are changed.
UP_PID Constants	This setup is necessary to use the UP_PID (use-point PID control) function block. The constants necessary for the control calculation, such as PID constants and output limit values are set and changed.
TBL / TBR Options	This setup is necessary to use the TBL (linearization table lookup) and TBR (linearization table reverse lookup) function blocks. The points in the linearization table are set and changed.

For details about TBL / TBR Setup Parameters,

☞ refer to Module Type Controller DMC50 User's Manual "Function Block Reference" CP-SP-1130E.

● Calculation Monitor Parameters

Type label	Description
PID_A Monitor	The status, such as PV, SP, MV, or mode can be checked when using the PID_A (standard PID control) function block. However, the values, such as SP cannot be set or changed.
PID_CAS Monitor	The status, such as PV, SP, MV, or mode can be checked when using the PID_CAS (cascade PID control) function block. However, the values, such as SP cannot be set or changed.
Ra_PID Monitor	The status, such as PV, SP, MV, or mode can be checked when using the Ra_PID (RationalLOOP PID control) function block. However, the values, such as SP cannot be set or changed.
UP_PID Monitor	The status, such as PV, SP, MV, or mode can be checked when using the UP_PID (use-point PID control) function block. However, the values, such as SP cannot be set or changed.

For details about the Calculation Monitor Parameters,
 refer to Module Type Controller DMC50 User's Manual "Function Block Reference" CP-SP-1130E.

● Program Pattern Parameters

Type label	Description
Pattern Setup	This Parameter data is used in the pattern function block.
Segment Setup	This Parameter data is used in the pattern function block.
Pattern FB Monitor	This monitor data is used in the pattern function block.

For details about Program Pattern Parameters,
 refer to Module Type Controller DMC50 User's Manual "Application Developer's Guide" CP-SP-1134E.

● User-defined Parameters

The user can freely define Parameters and use them.

For details about how to use User-defined Parameters,

 refer to Smart Loader Package SLP-D50 for Module Type Controller DMC50 User's Manual CP-SP-1122E.

7 - 2 System Parameters

■ AI Setup (High resolution type: for standard inputs)

This setup is only for the high resolution type (CH40X / 20X).

The settings related to the standard analog inputs (AI1 to AI4) are made.

Parameter type ID: 021h Group ID: 001 to 004h

Item ID	Item name	Setting range	Factory setting	User level	Remarks	Data type
1	Enable Input	0:Disabled. 1:Enabled.	1	0	When "Disabled" is specified, the AI value becomes "0.0". In this case, no alarms occur.	BOOL
2	Input Type	1 to 16:Thermocouple 21 to 22:RTD 31 to 32:Linear current 33 to 41:Linear voltage	1	0	Specify the input range.	DINT
3	Linear Input Scale Min.	-99999.9 to +99999.9	0.0	0	The settings are valid only if the input range is linear. The reverse scaling is possible.	REAL
4	Linear Input Scale Max.	-99999.9 to +99999.9	1000.0	0		
5	Input Bias	-99999.9 to +99999.9	0.0	0		
6	Input Filter	0.0 to 2000.0s	0.0s	0		
7	Cold junction compensation	0:Internally compensated. 1:Externally compensated at 0°C	0	0	This setting is valid only if the input type is thermocouple.	DINT
8	RTD 3 / 4 wire Selection	0:3-wire RTD 1:4-wire RTD	0	0	This setting is valid only if the input type is RTD.	
9	Burnout Indication	0:Upscale 1:Downscale	0	0	This setting is valid only if the input type is the thermocouple or linear voltage range in condition that the [Disable Burnout Current] item is set at "Not Disabled".	
10	Disable Burnout Current	0:Not Disabled 1:Disabled	0	0	This setting is valid only if the input type is thermocouple, RTD (4-wire), or linear voltage range.	BOOL

AI Setup (High resolution type: for standard inputs) consists of four channels (AI1 to AI4).

● **Item ID = 1 [Enable Input]**

Specify whether the input is enabled or disabled. If "Disabled" is selected, the input operation is not performed and the target AI value becomes "0.0". Furthermore, the AI alarm does not occur.

[!] **Handling Precautions**

In the factory settings, all channels have been set at " 1 (True=Enabled)". Before starting operation of this module, change the channels not in use to "0 (False=Disabled)". (If channels actually not in use are connected, relevant alarm is generated.)

● **Item ID = 2 [Input Type]**

This setting specifies the input range.

[!] **Handling Precautions**

By changing the input type, this module is made applicable to all kinds of input ranges. However, the input wiring terminal Nos. may vary depending on the thermocouple, RTD, or linear.

• Thermocouple input types

Range No.	Input type	Temperature range (°C)	Standards / Remarks
1	K(CA)	- 200 to + 1200 °C	JIS C 1602 - 1995
2	K(CA)	- 200 to + 400 °C	JIS C 1602 - 1995
3	E(CRC)	0 to 800 °C	JIS C 1602 - 1995
4	J(IC)	0 to 800 °C	JIS C 1602 - 1995
5	N(Nicr-Ni)	0 to 1300 °C	JIS C 1602 - 1995
6	PL II	0 to 1300 °C	Engelhard Industries
7	T(CC)	- 200 to + 300 °C	JIS C 1602 - 1995
8	B(PR30-6)	0 to 1800 °C	JIS C 1602 - 1995
9	R(PR13)	0 to 1600 °C	JIS C 1602 - 1995
10	S(PR10)	0 to 1600 °C	JIS C 1602 - 1995
11	PR40-20	0 to 1900 °C	Johnson Matthey
12	WRe5-26	0 to 2300 °C	ASTM E 988 - 1990
13	WRe5-26	0 to 1400 °C	ASTM E 988 - 1990
14	DIN L	- 200 to + 800 °C	DIN IEC 584 - 1984
15	DIN U	- 200 to + 400 °C	DIN 43710 - 1985
16	Ni-NiMo	0 to 1300 °C	General Electric

- RTD input types

Range No	Input type	Temperature range (°C)	Standards / Remarks
21	Pt100	- 200 to + 500 °C	JIS C 1604-1997
22	Pt100	- 60 to + 100 °C	JIS C 1604-1997

! Handling Precautions

- RTD is used only for the standard input. RTD cannot be used for the option input.
- RTD can be switched between 3-wire and 4-wire using the setting.

- Linear input types

Range No.	System	Input type	Programmable range
31	DC current (mA)	0 to 20 mA	-99999.9 to +99999.9 *
32		4 to 20 mA	
33	DC voltage (V)	0 to 10 V	
34		0 to 5 V	
35		1 to 5 V	
36		-1 to +1 V	
37		0 to 1 V	
38	DC voltage (mV)	-100 to +100 mV	
39		0 to 100 mV	
40		-10 to +10 mV	
41		0 to 10 mV	

*The decimal point position is valid in the range of REAL-type precision.

! Handling Precaution

DC current (0 to 20 mA, 4 to 20 mA) is used only for the standard input. DC current cannot be used for the option input.

● Item ID = 3 [Linear Input Scale Min.](If the input type is linear input.)

● Item ID = 4 [Linear Input Scale Max.](If the input type is linear input.)

Make the settings appropriately so that the minimum and maximum values of the linear input correspond to the minimum and maximum values in relevant industrial unit.

It is also possible to perform the scaling operation (reverse scaling operation) with the minimum setting set larger than the maximum setting.

- **Item ID = 5 [Input Bias]**

This setting is used to correct the AI value. The setting is used for the correction if the sensor deteriorates.

- **Item ID = 6 [Input Filter]**

The AI value can be passed through the first order digital filter after the bias calculation is applied if specified.

This setting is used if the AI value can not be controlled because it rapidly fluctuates repeatedly, or if the AI value vibrates a lot due to effects of noise.

$$\text{AI value} = \text{Previous AI value} + (\text{Current AI value} - \text{Previous AI value}) / (\text{T} / \text{Ts} + 1)$$

T: Input filter value (Filter calculation is not performed when this value is set at "0.0".)

Ts: Sampling time(Cycle time in Operating mode and 100 ms in Application inactive mode)

 **Note**

When it is necessary to perform the moving average filter operation to the input, the MAV (moving average) function block can be used in the application program.

- **Item ID = 7 [Cold Junction Compensation] (If the input type is thermo - couple.)**

When this setting is set at [Externally compensated at 0°C.], it is possible to perform the temperature compensation for the thermocouple wiring with an external ice box. In this case, the cold junction compensation facility inside this module is not used.

However, the compensation temperature for the external compensation is assumed 0°C (use of ice box or its equivalent is preconditioned).

- **Item ID = 8 [RTD 3 / 4 wire Selection] (If the input type is RTD.)**

This setting switches between the 3-wire RTD and 4-wire RTD. Make the setting properly corresponding to the sensor to be used.

- **Item ID = 9 [Burnout Indication] (If the input type is thermocouple or linear DC voltage.)**

If the input type is thermocouple or linear DC voltage, it is possible to switch the burnout indication between the upscale and downscale when the [Disable burnout current] item is set at "Not Disabled".

For details about burnout indication,

 refer to "Burnout indication," (page A-App.-12).

● **Item ID = 10 [Disable Burnout Current] (If the input type is thermocouple, RTD (4-wire), or linear DC voltage.)**

If the input type is thermocouple, RTD (4-wire), or linear DC voltage, this [Disable Burnout Current] item can be switched between "Not Disabled (burnout current enabled)" and "Disabled (burnout current disabled)".

Input type	Description
Thermocouple	Burnout current controlled by this setting.
Linear DC voltage	Burnout current controlled by this setting.
Linear DC current	Burnout current always enabled regardless of this setting.
RTD (3-wire)	Burnout current always enabled regardless of this setting.
RTD (4-wire)	Burnout current controlled by this setting.

! Handling Precautions

When the [Disable Burnout Current] item is set at "Disabled", the [Burnout Indication] setting becomes invalid and the burnout indication output becomes undefined (or fixed). For details about burnout indication, refer to the appendix, "Burnout indication," (page A-App. -12).

■ AI Setup (High resolution type: for option inputs)

This setup is only for the high resolution type (CH40X / 20X).

The settings related to the option analog inputs (option AI1 to AI4) are made.

Parameter type ID: 023h Group ID: 001 to 004h

Item ID	Item name	Setting range	Factory setting	User level	Remarks	Data type
1	Enable Input	0: Disabled. 1: Enabled.	1	0	When "Disabled" is specified, the AI value becomes "0.0". In this case, no alarms occur.	BOOL
2	Input Type	1 to 16: Thermocouple 33 to 41: Linear voltage	1	0	Set the input range.	DINT
3	Linear Input Scale Min.	-99999.9 to +99999.9	0.0	0	The settings are valid only if the input range is linear. The reverse scaling is possible.	REAL
4	Linear Input Scale Max.	-99999.9 to +99999.9	1000.0	0		
5	Input Bias	-99999.9 to +99999.9	0.0	0		
6	Input Filter	0.0 to 2000.0s	0.0s	0		
7	Cold junction compensation	0: Internally compensated. 1: Externally at compensated 0°C.	0	0	This setting is valid only if the input type is thermocouple.	DINT
8	Burnout Indication	0: Upscale 1: Downscale	0	0	This setting is valid only if the [Disable Burnout Current] item is set at "Not Disabled".	
9	Disable Burnout Current	0: Not Disabled 1: Disabled	0	0		BOOL

AI Setup (High resolution type: for option inputs) consists of four channels (option AI1 to option AI4).

● About option inputs

For the high resolution type (CH40X / 20X), one additional channel can be used as optional input for each channel (ch1 to ch4) by changing the range setting combination. This added channel input is called "option input".

● Operating conditions for option inputs

The operating conditions for option inputs are determined by the standard input range setting of the same channel number as shown in the following table:

Standard input range setting	Range to be used for option inputs
Disabled.	Thermocouple range Linear DC voltage
Thermocouple range	Thermocouple range Linear DC voltage
RTD range	Cannot be used.
Linear DC voltage	Thermocouple range Linear DC voltage
Linear DC current	Cannot be used.

! Handling Precautions

- When the range setting of the standard input and that of the option input for the same channel number are enabled at the same time, the setting of the standard input takes precedence over the other. (For example, if the standard input range is set at RTD and the option input range is set at linear DC voltage, the option input cannot be used.)
- If any conditions under which the option input cannot be used are specified, the AI alarm (setting error) may occur. If this occurs, change the combination to that of correct range settings.

● **Item ID = 2** [Input type]

This setting specifies the input range.

• Thermocouple input types

Range No	Input type	Temperature range(°C)	Standards / Remarks
1	K(CA)	-200 to +1200 °C	JIS C 1602 - 1995
2	K(CA)	-200 to +400 °C	JIS C 1602 - 1995
3	E(CRC)	0 to 800 °C	JIS C 1602 - 1995
4	J(IC)	0 to 800 °C	JIS C 1602 - 1995
5	N(Nicr-Ni)	0 to 1300 °C	JIS C 1602 - 1995
6	PL II	0 to 1300 °C	Engelhard Industries
7	T(CC)	-200 to +300 °C	JIS C 1602 - 1995
8	B(PR30-6)	0 to 1800 °C	JIS C 1602 - 1995
9	R(PR13)	0 to 1600 °C	JIS C 1602 - 1995
10	S(PR10)	0 to 1600 °C	JIS C 1602 - 1995
11	PR40-20	0 to 1900 °C	Johnson Matthey
12	WRe5-26	0 to 2300 °C	ASTM E 988 - 1990
13	WRe5-26	0 to 1400 °C	ASTM E 988 - 1990
14	DIN L	-200 to +800 °C	DIN IEC 584 - 1984
15	DIN U	-200 to +400 °C	DIN 43710 - 1985
16	Ni-NiMo	0 to 1300 °C	General Electric

• Linear input types

Range No	System	Input type	Programmable range
33	DC voltage (V)	0 to 10 V	-99999.9 to +99999.9 *
34		0 to 5 V	
35		1 to 5 V	
36		-1 to +1 V	
37		0 to 1 V	
38	DC voltage (mV)	-100 to +100 mV	
39		0 to 100 mV	
40		-10 to + 10 mV	
41		0 to 10 mV	

*The decimal point position is valid in the range of REAL-type precision.

! Handling Precautions

DC current (0 to 20 mA, 4 to 20 mA) can be used only for the standard input. The DC current cannot be used for the option input.

● About detailed description of the items

■ The contents are the same as those of the AI Setup (High resolution type: for standard input).

☞ Refer to page 7-5.

For details about burnout indication,

☞ refer to the appendix, Burnout indication, (page A-App.-12).

■ AI Setup (Special type)

This setup is only for the special type (CS40X / 20X).

The settings related to the analog inputs (AI1 to AI4) are made.

Parameter type ID: 022h Group ID: 001 to 004h

Item ID	Item name	Setting range	Factory setting	User level	Remarks	Data type
1	Enable Input	0:Disabled. 1:Enabled.	1	0	When "Disabled" is specified, the AI value becomes "0.0". In this case, no alarms occur.	BOOL
2	Input Type	23 to 24:RTD 33 to 39:Linear voltage	23	0	Set the input range.	DINT
3	Linear Input Scale Min.	-99999.9 to +99999.9	0.0	0	The settings are valid only if the input range is linear. The reverse scaling is possible.	REAL
4	Linear Input Scale Max.	-99999.9 to +99999.9	1000.0	0		
5	Input Bias	-99999.9 to +99999.9	0.0	0		
6	Input Filter	0.0 to 2000.0s	0.0s	0		
7	Burnout Indication	0:Upscale. 1:Downscale	0	0	This setting is valid only if the input type is linear voltage range in condition that the [Disable Burnout current] item is set at "Not Disabled".	DINT
8	Disable Burnout Current	0:Not Disabled 1:Disabled	0	0		BOOL

AI Setup (Special type) consists of four channels (AI1 to AI4).

● **Item ID = 2 [Input Type]**

This setting specifies the input range.

• RTD input types

Range No	Input type	Temperature range(°C)	Standards / Remarks
23	Pt100	16 to 37 °C	JIS C 1604 - 1997
24	Pt100	-50 to +150 °C	JIS C 1604 - 1997

• Linear input types

Range No	System	Input type	Programmable range
33	DC voltage (V)	0 to 10 V	- 99999.9 to + 99999.9 *
34		0 to 5 V	
35		1 to 5 V	
36		-1 to +1 V	
37		0 to 1 V	
38	DC voltage (mV)	-100 to +100 mV	
39		0 to 100 mV	

*The decimal point position is valid in the range of REAL-type precision.

 **Handling Precautions**

- The input type of the special type (CS40X / 20X) does not include the thermocouple and linear DC current (mA) ranges.
- Only 4-wire RTD can be used.

● **About detailed description of the items**

■ The contents are the same as those of the AI Setup (High resolution type: for standard input).

 Refer to page 7-5.

For details about burnout indication,

 refer to the appendix, Burnout indication (page A-App. -12).

■ AUX-IN Setup

The settings related to the auxiliary inputs (AUX-IN1 to AUX-IN2) are made.

Parameter type ID: 041h Group ID: 001 to 002h

Item ID	Item name	Setting range	Factory setting	User level	Remarks	Data type
1	Enable Input	0:Disabled. 1:Enabled.	0	0	When "Disabled" is specified, the AI value becomes "0.0". In this case, no alarms occur.	BOOL
2	Input Type	0:AC voltage (5V reference) 1:AC voltage (6V reference) 2:AC voltage (10V reference) 3:AC voltage (12V reference) 4:DC voltage (1 to 5V)	0	0	0:AC voltage ranging from 0 to 5V is mapped to 0 to 100%. 1:AC voltage ranging from 0 to 6V is mapped to 0 to 100%. 2:AC voltage ranging from 0 to 10V is mapped to 0 to 100%. 3:AC voltage ranging from 0 to 12V is mapped to 0 to 100%. 4:DC voltage 1 to 5V (Linear)	DINT
3	Linear Input Scale Min.	-99999.9 to +99999.9	0.0	0	This setting is valid only if the input type is 4.	REAL
4	Linear Input Scale Max.	-99999.9 to +99999.9	1000.0	0	The reverse scaling is also possible.	
5	Input Bias	-99999.9 to +99999.9	0.0	0		
6	Input Filter	0.0 to 2000.0s	0.0s	0		

AUX-IN Setup consists of two channels (AUX-IN1 to AUX-IN2).

For details about burnout indication,

 refer to the appendix, Burnout indication (page A-App. -12).

● About auxiliary inputs

The auxiliary inputs (AUX-IN) are AC voltage inputs intended to correct a fluctuation in power supply voltage. Additionally, DC voltage can also be input by changing the input type setting.

In this case, the DC voltage input can be used as normal linear input.

Note

To correct a fluctuation in power supply voltage, the PSVC (power supply voltage correction) function block is used in the application program. In this case, use AC voltage as the input type.

● **Item ID = 1 [Enable Input]**

This setting makes the input channel "Enabled" or "Disabled".

If "Disabled" is selected, the input operation is not performed and the target AUX-IN value becomes "0.0". If the input type is DC voltage, the AUX-IN alarm does not occur. (If the input type is AC voltage, the AUX-IN alarm does not occur all the time.)

● **Item ID = 2 [Input Type]**

This setting specifies the input range.

Range No.	AC / DC	Input type	Range
0	AC voltage	5V reference	Input ranging from 0 to 5V is mapped to 0 to 100%.
1		6V reference	Input ranging from 0 to 6V is mapped to 0 to 100%.
2		10V reference	Input ranging from 0 to 10V is mapped to 0 to 100%.
3		12V reference	Input ranging from 0 to 12V is mapped to 0 to 100%.
4	DC voltage	1 to 5V	Programmable (-99999.9 to +99999.9) *

*The decimal point position is valid in the range of REAL-type precision.

 **Handling Precautions**

- By changing the input type setting, this module is made applicable to either AC or DC voltage. However, the input wiring terminal Nos. for the AC voltage are different from those for DC voltage.
- When the input type is AC voltage, the AUX-IN alarm does not occur.

● **Item ID = 3 [Linear Input Scale Min.](If the input type is DC voltage.)**

● **Item ID = 4 [Linear Input Scale Max.](If the input type is DC voltage.)**

Make the settings appropriately so that the minimum and maximum values of the linear input correspond to the minimum and maximum values in relevant industrial unit.

It is also possible to perform the scaling operation (including reverse scaling operation) with the minimum setting set larger than the maximum setting.

 **Note**

For the AC voltage range, the scaling is automatically calculated inside this module regardless of this setting. The AC voltage range is an input intended to correct a fluctuation in heater power voltage. To correct the heater power voltage, data "100 ± approximately 20%" is needed to detect a fluctuation in voltage. Therefore, the scaling is fixed by the input type setting so that it is calculated automatically by taking a combination of the transformer and heater voltage into consideration.

Heater operating voltage	Transformer to be used	Input type to be used	Automatic scaling results
100V	1 / 10	2:AC voltage, 10V reference	0 to near 144% assuming that the input ranging from 0 to 10V is mapped to 0 to 100%.
	1 / 20	0:AC voltage, 5V reference	0 to near 288% assuming that the input ranging from 0 to 5V is mapped to 0 to 100%.
120V	1 / 20	1:AC voltage, 6V reference	0 to near 240% assuming that the input ranging from 0 to 6V is mapped to 0 to 100%.
200V	1 / 20	2:AC voltage, 10V reference	0 to near 144% assuming that the input ranging from 0 to 10V is mapped to 0 to 100%.
240V	1 / 20	3:AC voltage, 12V reference	0 to near 120% assuming that the input ranging from 0 to 12V is mapped to 0 to 100%.

AUX-IN value = (Input AC voltage / Reference voltage) × 100

Reference voltage: This voltage is determined by "Heater operating voltage × Transformer to be used", and set as input type.

Input AC voltage: Approximately 0.0 to 14.4V

● **Item ID = 5 [Input Bias]**

This setting is used to correct the AUX-IN value.

 **Note**

When using the PSVC (power supply voltage correction) function block, adjust the input bias appropriately so that the AUX-IN value become 100% in the reference state. Here, this reference state means the stable state, in which the power voltage does not fluctuate.

● **Item ID = 6 [Input Filter]**

The AUX-IN value can be passed through the first order digital filter after the bias calculation is applied if specified.

This setting is used if the AUX-IN value vibrates a lot due to effects of noise.

AUX-IN value = Previous AUX-IN value + (Current AUX-IN value - Previous AUX-IN value) / (T / Ts + 1)

T:Input filter value (Filter calculation is not performed when this value is set at "0.0".)

Ts:Sampling time(Cycle time in Operating mode and 100 ms in Application inactive mode)

 **Note**

When it is necessary to perform the moving average filter operation to the input, the MAV (moving average) function block can be used in the application program.

■ Zener Barrier Adjustment Values

This setting is only for the high resolution type (CH40X / 20X).

Set the values used to adjust the zener barrier when working with RTD.

Parameter type ID:074h Group ID:001h

Item ID	Item name	Setting range	Factory setting	User level	Remarks	Data type
1	Zener Barrier Adjustment Val 1	-100.0 to +100.0Ω	0.0Ω	1	For channel 1	REAL
2	Zener Barrier Adjustment Val 2	-100.0 to +100.0Ω	0.0Ω	1	For channel 2	
3	Zener Barrier Adjustment Val 3	-100.0 to +100.0Ω	0.0Ω	1	For channel 3	
4	Zener Barrier Adjustment Val 4	-100.0 to +100.0Ω	0.0Ω	1	For channel 4	

For details about how to adjust the zener barrier,

☞ refer to the appendix, How to adjust the zener barrier (page A-App.-14).

■ AO Setup

The settings related to the analog outputs (AO1 to AO4) are made.

Parameter type ID: 045h Group ID: 001 to 004h

Item ID	Item name	Setting range	Factory setting	User level	Remarks	Data type
1	Output Type	0:Current proportional output (0 to 20 mA) 1:Current proportional output (4 to 20 mA) 2:Voltage proportional output (0 to 10 V) 3:Time-proportional current output	1	0	Output method selections.	DINT
2	Time Proportioning Current Level	2 to 22mA	15mA	0	This setting is valid only when the time-proportional current output is selected (for SSR adjustment). Normally, this setting item is used at "factory setting".	
3	Time Proportioning Cycle Time	1 to 120s	1s	0	This setting is valid only when the time-proportional current output is selected.	
4	Time Proportioning Mode	0:Priority on controllability 1:Priority on device life	0	0	When this setting is set at "1", the ON / OFF operation is performed only once in a Time proportioning cycle.	
5	Output Not in Operating Mode	0:Preset output value 1:Bumpless transfer	0	0		
6	Preset Output Value	-10.0 to +110.0%	0.0%	0		REAL

AO Setup consists of four channels (AO1 to AO4).

● **Item ID = 1 [Output Type]**

This setting specifies the output method.

Setting	Output method
0	Current proportional output (0 to 20 mA)
1	Current proportional output (4 to 20 mA)
2	Voltage proportional output (0 to 10 V)
3	Time-proportional current output

! Handling Precautions

By changing the output type setting, this module is made applicable to all kinds of outputs. However, the output wiring terminal Nos. may be changed.

● **Item ID = 2 [Time Proportioning Current Level]**

When driving a SSR (Solid State Relay) using the time proportional current output, the output voltage of this module must be within the input rating voltage (optimal ignition voltage) range of the SSR.

In this module, a new variable output method is developed and utilized to output an optimal ignition voltage even when multiple SSRs are driven. This method is intended to set an appropriate current value on this module and output it in order to obtain an ignition voltage most suitable for the internal impedance on the SSR.

The following shows the formulas related to equivalent circuits:

- Description of symbols

(1) Contents

I_0	:Output current set on this module(Setting range: 2 to 22 mA)
V_0	:Maximum voltage applied to the load (Approximately 11.0 V)
V_{SSR}'	:Actual voltage input to SSR
V_{SSR}	:Input rating voltage range of SSR (V_{SSR} / MIN to V_{SSR} / MAX)
V_{SSR} / MIN	:Minimum input rating voltage of SSR
V_{SSR} / MAX	:Maximum input rating voltage of SSR
Z	:Internal impedance of SSR
V_D	:Internal voltage drop of SSR(Normally, this voltage is approximately 1 to 2V.)

(2) Equivalent circuit when one SSR is connected.

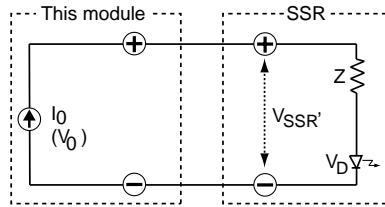

It is necessary to satisfy the following formulas (1) and (2):

$$V_{SSR} / \text{MIN} \leq I_0 \times Z + V_D \leq V_0 \quad \text{Formula (1)}$$

$$V_{SSR}' \leq V_{SSR} / \text{MAX} \quad \text{Formula (2)}$$

$$(V_{SSR}' = I_0 \times Z + V_D)$$

(3) Equivalent circuit when N units of SSR are connected in series.

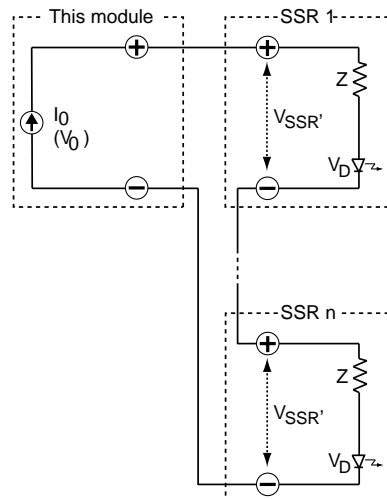

It is necessary to satisfy the following formulas (3) and (4):

$$V_{SSR} / \text{MIN} \leq I_0 \times Z + V_D \leq V_0 / N \quad \text{Formula (3)}$$

$$V_{SSR}' \leq V_{SSR} / \text{MAX} \quad \text{Formula (4)}$$

$$(V_{SSR}' = I_0 \times Z + V_D)$$

(4) Equivalent circuit when N units of SSR are connected in parallel.

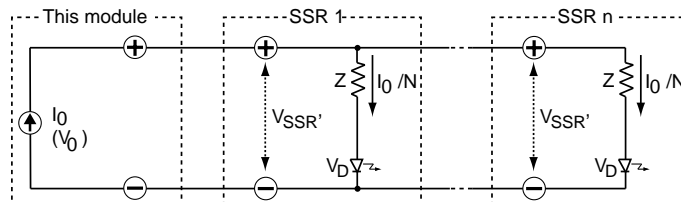

It is necessary to satisfy the following formulas (5) and (6):

$$V_{SSR} / \text{MIN} \leq I_0 / N \times Z + V_D \leq V_0 \quad \text{Formula (5)}$$

$$V_{SSR}' \leq V_{SSR} / \text{MAX} \quad \text{Formula (6)}$$

$$(V_{SSR}' = I_0 / N \times Z + V_D)$$

(5) Example) Yamatake's SSR:PGM is used.

V_{SSR} : 3 to 6V

Z : $260 \Omega \pm 5\%$

V_D : 0.8 to 1.3V

•How is I_0 determined when connecting one PGM?

The voltage output part of this module uses the constant current method as shown in the Figure on the right. Therefore,

$8.9\text{mA} \leq I \leq 17.2\text{mA}$ is obtained from the following formulas according to the input voltage range of the PGM:

$$I_{\text{MIN}} \times Z_{\text{MIN}} + V_{D / \text{MIN}} > 3$$

$$I_{\text{MIN}} > 8.9\text{mA}$$

$$I_{\text{MAX}} \times Z_{\text{MAX}} + V_{D / \text{MAX}} < 6$$

$$I_{\text{MAX}} < 17.2\text{mA}$$

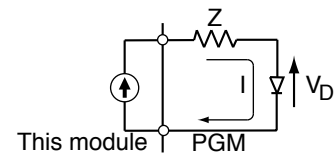

• How many PGM units can be connected?

A current of 8.9 mA or more needs to flow through one PGM. On the other hand, the maximum output current of this module is 22 mA.

Therefore, two units can be connected in parallel.

When connecting the units in series, the maximum voltage value to be applied to the load becomes 11.0 V ($22 \text{ mA} \times 500 \Omega$) according to the maximum output current of 22 mA and the maximum allowable load resistance of 500Ω .

Additionally, when a current of 8.9 mA flows into the PGM, the maximum value of the voltage between both input terminal ends becomes 3.7 V.

$$0.0089 \times 260 \times 1.05 + 1.3 = 3.7\text{V}$$

Therefore, $11.0 / 3.7 = 2.97$. According to this calculation result, two units can be connected in series.

Note that the above explanation shows the calculation assuming the worst case.

For example, even though three units are connected in series, they function correctly when a voltage of 3V or more is applied to each PGM unit in the voltage ON state.

● Item ID = 3 [Time Proportioning Cycle Time]

This setting sets a cycle time for the time proportional output.

A value that this time is multiplied by the AO value / 100 (normally, the control output value) becomes ON time. Generally, as the time proportioning cycle time is shorter, the controllability is improved.

However, as the time proportioning cycle time is too short, ON and OFF are repeated frequently. Therefore, this item is set appropriately by taking the device life into consideration.

● Item ID = 4 [Time Proportioning Mode]

This setting sets an operation method for the time proportional output.

- Priority on controllability

Even though the output is OFF, it is turned ON again when the AO value (normally, the control output value) is changed in the middle of a time proportioning cycle.

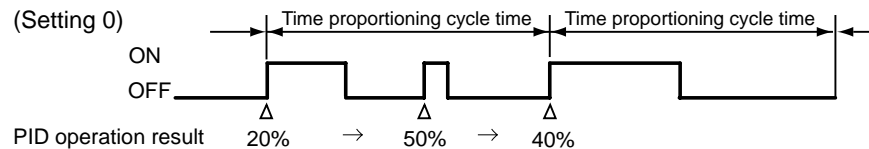

- Priority on device life

Even though the AO value (normally, the control output value) is changed in the middle of a time proportioning cycle, ON / OFF is performed only once during time proportioning cycle time.

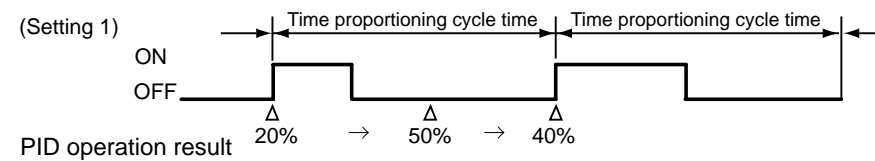

⚠ Handling Precautions

To reduce the operation frequency at final control element (e.g. mechanical relays), it is also recommended to extend the time proportioning cycle time.

● Item ID = 5 [Output Not in Operating Mode]

● Item ID = 6 [Preset Output Value]

This setting specifies the AO output value when the mode is transited from Operating mode to Application inactive mode and vice versa, or when the power is turned ON.

For details about preset / bumpless operation,

☞ refer to the appendix, Preset / bumpless operation of AO, DO, and TP (page A-App.-15).

■ DO Setup

The settings related to the digital outputs (DO1 to DO16) are made.

Parameter type ID: 061h Group ID: 001 to 010h (0 to 16)

Item ID	Item name	Setting range	Factory setting	User level	Remarks	Data type
1	Output Type	0:DO output 1:Time Proportional Output (TP output)	0	0		DINT
2	Output Not in Operating Mode	0:Preset output value 1:Bumpless transfer	0	0		
3	Preset Output Value	0:OFF 1:ON	0	0		BOOL

DO Setup consists of 16 channels (DO1 to DO16).

● Item ID = 1 [Output type]

This setting specifies the output method.

Select whether the digital output of this module is used as ON / OFF output (DO output) or time proportional output (TP output).

Setting	Output method	Description
0	DO	Digital output is used as ON / OFF.
1	TP	Digital output is used as time proportional output.

● Item ID = 2 [Output Not in Operating Mode]

● Item ID = 3 [Preset Output Value]

This setting specifies the DO output value when the mode is transited from Operating mode to Application inactive mode and vice versa, or when the power is turned ON.

For details about preset / bumpless operation,

☞ refer to the appendix, Preset / bumpless operation of AO, DO, and TP (page A-App. -15).

ⓘ Handling Precautions

These settings are used for the digital output as ON / OFF output (when [Output Type] is set to [DO output].)

Edit the relevant settings in [TP Setup] when the digital output is used for time proportional output (TP output).

■ TP Setup

The settings related to the TP outputs (TP1 to TP16) are made.

Parameter type ID: 071h Group ID:001 to 010h (0 to 16)

Item ID	Item name	Setting range	Factory setting	User level	Remarks	Data type
1	Output Method	0:Direct 1:Reverse	0	0	This setting is valid only when [Output type] of the DO setup is set at "1".When this setting is set at "1" (reverse), the physical and logical outputs are reversed.	BOOL
2	Time proportioning cycle time	1 to 120s	10 s	0	This setting is valid only when [Output Type] of the DO setup is set at "1".	DINT
3	Time Proportioning Mode	0:Priority on controll ability 1:Priority on device life	0	0	This setting is valid only when [Output Type] of the DO setup is set at "1". When this setting is set at "1", the ON / OFF operation is performed only once within the time proportioning cycle time.	
4	Output Not in Operating Mode	0:Preset output 1:Bumpless output	0	0	This setting is valid only when [Output Type] of the DO setup is set at "1".	
5	Preset Output Value	0.0 to 100.0%	0.0%	0		REAL

TP Setup consists of 16 channels (TP1 to TP16).

● About TP (Time proportioning)

By selecting the appropriate value in [Output Type] of the DO Setup, the digital output can be used as time proportional output (TP output). The time proportional output of the analog output (AO) is the current output, while this TP output is the time proportional output using the open collector. The range of the TP value is "0.0 to 100.0%" and that of the output resolution is "0.1%". The time proportional output is performed according to the time proportioning cycle time. Additionally, direct action and reverse action (physical output and logical output are reversed) can be performed by changing the setting in [Output Method].

ⓘ Handling Precautions

- To use the digital output as time proportional output (TP output), it is necessary to set [Output Type] of the DO Setup to "TP output".
- When using the digital output as time proportional output (TP output), the execution time of the application program is increased. When using the digital output as TP output, it is possible to suppress the increase of the execution time by decreasing the number of channels or by making the time proportioning cycle time longer by [Time proportioning cycle time]

● Item ID = 1 [Output Type]

Normal actuators can be used with this setting set at "0" (direct). When this setting is set at "1" (reverse), the physical and logical outputs of the time proportional output are reversed.

● Detailed description of the other items

The descriptions of other items are the same as those of the AO setup.

For details about preset / bumpless operations,

☞ refer to the appendix, Preset / Bumpless operations of AO, DO, and TP (page A-App. -15).

■ Date and Time Setup

The date and time of the built-in real time clock of this module are set.

Parameter type ID: 002h Group ID: 001h

Item ID	Item name	Setting range	User level	Remarks	Data type
1	Year / Month / Day	00 01 01 to 99 12 31 (BCD format)	0	This data is a value in the BCD format of "yymmdd". This value expresses yy (year)-mm (month) -dd (day). "yy" shows the lower 2-digit value of the Christian year (1990 to 2089).	DWORD
2	Hour / Min / Sec	0 to 23 59 59 (BCD format)	0	This data is a value in the BCD format of "hhmmss". This value expresses hh (hour) -mm (minute)-ss (second). "hh" shows a value in the 24-hour format.	

● Item ID = 1 [Year / Month / Day]

The data of yymmdd expresses yy (year)-mm (month)-dd (day). "yy" shows the lower 2-digit value of the Christian year (1990 to 2089).

For example, to specify "January 1, 2000", enter "000101".

When [Year / Month / Day] is set, the day of the week is automatically set inside this module.

By reading this setting, it is also possible to check the currently set value.

● Item ID = 2 [Hour / Min / Sec]

The data of hhmmss expresses hh (hour)-mm (minute)-ss (second). "hh" shows a value in the 24-hour format.

For example, to specify "1:30:30 P.M.", enter "133030".

By reading this setting, it is also possible to check the currently set value.

■ Front Port Communication Setup

The settings related to the front port are made.

Parameter type ID:0A3h Group ID:001h

Item ID	Item name	Setting range	Factory setting	User level	Remarks	Data type
1	Trans. Speed (OIT port)	9600bps 19200bps 38400bps	9600bps	0		DINT

The transmission speed of the OIT(Operator Interface Terminal) port can be changed.

For details about communication capabilities,

☞ refer to **Module Type Controller DMC50 User's Manual**
"Communications Connection" CP-SP-1093E.

Note

- Two front ports are provided: "OIT port" and "Loader port".
- When communicating via the loader port, the transmission speed is fixed at "9600 bps".

Handling Precautions

- If the transmission speed is changed, this setting will take effect when the power is turned ON next time. Therefore, it is necessary to turn OFF the power, and turn it ON again if the transmission speed is changed.
- Note that the loader port and OIT port cannot be used at the same time.
If the jack for the loader communication and the connector for the OIT communication are connected at the same time, the communication cannot be performed correctly.
- The Front Port Communication Setup cannot be changed through the CPL communication. The setting must be changed from the SLP-D50.
- For the CTRL module, the setting cannot be changed in Operating mode. Always change the setting in the Application inactive mode.

7-3 System Monitor Parameters

■ System Alarm Log

Up to 16 latest system alarm generation / reset records can be checked.

Parameter type ID: 0C4h Group ID: 001h

Item ID	Item name	Setting range	User level	Remarks	Data type
1	Latest Log Number	0 to 16	0	Latest Log Number "0" means that no logs exist.	DINT
2	Log 1 (Contents)	0 to FFFFFFFF	0	System alarm log (HEX format)	DWORD
3	Log 1 (Year/Month/Day)	00 01 01 to 99 12 31 (BCD format)	0	The year / month / day data of the system alarm generation / reset is a value in the BCD format of "yymmdd". This value expresses yy (year) -mm (month)-dd (day). "yy" shows the lower 2-digit value of the Christian year (1990 to 2089).	
4	Log 1 (Hour/Min/Sec)	0 to 23 59 59 (BCD format)	0	The hour / min / sec data of the system alarm generation / reset is a value in the BCD format of "hhmmss". This value expresses hh (hour) -mm (minute)-ss (second). "hh" shows a value in the 24-hour format.	
⋮	⋮	⋮ ⋮	⋮	⋮	
47	Log 16(Contents)		0		
48	Log 16(Year/Month/Day)		0		
49	Log 16(Hour/Min/Sec)		0		

For details about logging capability,
 refer to the appendix, Logging capability (page A-App. - 6).

● Item ID = 1 [Latest Log Number]

This shows the latest logged record number. When this value is 0, this shows that no logs exist.

Once the logging is performed, the value will be incremented only in a range from 1 to 16.

The next number of latest log number 16 is "1".

Additionally, when the value is set to "0", all the log data will be cleared so that 16 records of [Log (Contents)], [Log (Year / Month / Day)], and [Log (Hour / Min / Sec)] data are cleared to "0".

● Item ID = 2 to 49 [Log (Contents)], [Log (Year / Month / Day)], and [Log (Hour / Min / Sec)]

The logging results of the system alarms are shown. For details about system alarms,

 refer to the appendix, System status bit data (page A-App. - 1).

■ AI Alarm Log

Up to 16 latest AI alarm generation / reset records can be checked.

Parameter type ID: 0C5h Group ID: 001h

For details about logging capability,

Item ID	Item name	Setting range	User level	Remarks	Data type
1	Latest Log Number	0 to 16	0	Latest Log Number "0" means that no logs exist.	DINT
2	Log 1 (Contents)	0 to FFFFFFFF	0	AI alarm log (HEX format)	DWORD
3	Log 1 (Year/Month/Day)	00 01 01 to 99 12 31 (BCD format)	0	The year / month / day data of the AI alarm generation / reset is a value in the BCD format of "yymmdd". This value expresses yy (year)-mm (month)-dd (day). "yy" shows the lower 2-digit value of the Christian year (1990 to 2089).	
4	Log 1 (Hour/Min/Sec)	0 to 23 59 59 (BCD format)	0	The hour / min / sec data of the AI alarm generation / reset is a value in the BCD format of "hhmmss". This value expresses hh (hour)-mm (minute)-ss (second). "hh" shows a value in the 24-hour format.	
⋮	⋮	⋮	⋮	⋮	
47	Log 16(Contents)		0		
48	Log 16(Year/Month/Day)		0		
49	Log 16(Hour/Min/Sec)		0		

 refer to the appendix, Logging capability (page A-App.- 6).

● Item ID = 1 [Latest Log Number]

This shows the latest logged record number. When this value is 0, this shows that no logs exist.

Once the logging is performed, the value will be incremented only in a range from 1 to 16.

The next number of latest log number 16 is "1".

Additionally, when the value is set to "0", all the log data will be cleared so that 16 records of [Log (Contents)], [Log (Year / Month / Day)], and [Log (Hour / Min / Sec)] data are cleared to "0".

● [Log (Contents)]

The logging results of the AI alarm are shown. For details,

 refer to the appendix, System status bit data (page A-App.- 1).

■ AUX-IN Alarm Log

Up to 16 latest AUX-IN alarm generation / reset records can be checked.

Parameter type ID: 0C6h Group ID: 001h

Item ID	Item name	Setting range	User level	Remarks	Data type
1	Latest Log Number	0 to 16	0	Latest Log Number "0" means that no logs exist.	DINT
2	Log 1 (Contents)	0 to FFFFFFFF	0	AUX-IN alarm log (HEX format)	DWORD
3	Log 1 (Year/Month/Day)	00 01 01 to 99 12 31 (BCD format)	0	The year / month / day data of the AUX-IN alarm generation / reset is a value in the BCD format of "yymmdd". This value expresses yy (year)-mm (month)-dd (day). "yy" shows the lower 2-digit value of the Christian year (1990 to 2089).	
4	Log 1 (Hour/Min/Sec)	0 to 23 59 59 (BCD format)	0	The hour / min / sec data of the AUX-IN alarm generation / reset is a value in the BCD format of "hhmmss". This value expresses hh (hour)-mm (minute)-ss (second). "hh" shows a value in the 24-hour format.	
⋮	⋮	⋮ ⋮	⋮	⋮	
47	Log 16(Contents)		0		
48	Log 16(Year/Month/Day)		0		
49	Log 16(Hour/Min/Sec)		0		

For details about logging capability,

☞ refer to the appendix, Logging capability (page A-App.- 6).

● Item ID = 1 [Latest Log Number]

This shows the latest logged record number. When this value is 0, this shows that no logs exist.

Once the logging is performed, the value will be incremented only in a range from 1 to 16.

The next number of latest log number 16 is "1".

Additionally, when the value is set to "0", the log data will be cleared so that all the 16 records of [Log (Contents)], [Log (Year / Month / Day)], and [Log (Hour / Min / Sec)] data are cleared to "0".

● [Log (Contents)]

The logging results of the AUX-IN alarm are shown. For details, ☞ refer to the appendix, System status bit data (page A-App.- 1).

■ H / W Info

The model and ROM revision of this module can be checked.

Parameter type ID: 001h Group ID: 001h

Item ID	Item name	Setting range	User level	Remarks	Data type
1	ROM ID	Not writable.	0		DINT
2	ROM ITEM		0		
3	ROM Revision		0		
4	Model ID		0	For model identification	
5	Module Type 1		0	For module type identification	
6	Module Type 2		0	Additional information by module type	
7	Num of AI Points		0		
8	Num of AUX-IN Points		0		
9	Num of AO Points		0		
10	Num of DI Points		0		
11	Num of DO Points		0		
12	Communication Option		0	Bit data (HEX format)	
13	Rotary Switch Position		0	For checking of module address. This shows the rotary switch position when the power is turned ON. Even though the rotary switch is changed while the power is being supplied, this setting does not reflect the change immediately.	

● Item ID = 4 [Model ID]

Data	Description
21	CH20X (CTRL module: High resolution 2-loop type)
22	CH40X (CTRL module: High resolution 4-loop type)
31	CS20X (CTRL module: Special 2-loop type)
32	CS40X (CTRL module: Special 4-loop type)

● Item ID = 5 [Module Type 1]

Data	Description
0	NG (Board configuration error)
2	CTRL module

● Item ID = 6 [Module Type2]

Data	Description
0	NG (Board configuration error)
1	Reserved for future extension
2	High resolution type
3	Special type

● Item ID = 12 [Communication Option]

Model	Built-in communication ports				Data
	bit3	bit2	bit1	bit0	
	Ethernet port	RS-485 port 2	RS-485 port 1	OIT port Loader port	
CH40X / 20X CS40X / 20X	No	No	No	Yes	0001 h

■ System Status

The alarm status of this module can be checked.

Parameter type ID: 0C1h Group ID: 001h

Item ID	Item name	Setting range	User level	Remarks	Data type
1	System Alarms	Not writable. (HEX format)	0		DWORD
2	AI Alarms		0		
3	AUX-IN Alarms		0		

The System Status is expressed by the bit data.

For details,

☞ refer to the appendix, System Status bit data (page A-App.-1).

■ Date and Time Display

The current date and time of the built-in real time clock of this module are displayed.

Parameter type ID: 0C3h Group ID: 001h

Item ID	Item name	Setting range	User level	Remarks	Data type
1	Year	Not writable.	0	Christian year (1990 to 2089)	DINT
2	Month		0		
3	Day		0		
4	Day of Week		0	0: Sunday, 1: Monday, 2: Tuesday, 3: Wednesday, 4: Thursday, 5: Friday 6: Saturday	DWORD
5	Hour		0	24-hour system	DINT
6	Min		0		
7	Sec		0		

■ AI Status

The values of the analog inputs (AI1 to AI4) can be monitored in relevant industrial unit.

Parameter type ID: 0E1h Group ID: 001h

Item ID	Item name	Setting range	User level	Remarks	Data type
1	AI 1	Not writable.	0		REAL
2	AI 2		0		
3	AI 3		0		
4	AI 4		0		
5	Option AI 1		0	For high resolution type (CH40X/20X) only	
6	Option AI 2		0		
7	Option AI 3		0		
8	Option AI 4		0		

For details about relationship among the AI Status data (AI1 to AI4, Option AI1 to AI4) and I / O variables used in the application program,

refer to the appendix, Relationship among System Monitor Parameters and I / O variables (page A-App.- 9).

■ AUX-IN Status

The values of the auxiliary inputs (AUX-IN1 to AUX-IN2) are monitored as values in % for the AC voltage range and values in relevant industrial unit for the DC voltage range.

Parameter type ID: 0E2h Group ID: 001h

Item ID	Item name	Setting range	User level	Remarks	Data type
1	AUX-IN 1	Not writable.	0		REAL
2	AUX-IN 2		0		

For details about relationship among the AUX-IN Status data (AUX-IN1 to AUX-IN2) and I / O variables used in the application program,

☞ refer to the appendix, Relationship among System Monitor Parameters and I / O variables (page A-App.- 9).

■ AO Status

The values of the analog outputs (AO1 to AO4) are monitored as values in %.

Parameter type ID: 0E3h Group ID: 001h

Item ID	Item name	Setting range	User level	Remarks	Data type
1	AO 1	-10.0 to +110.0%	0	The values can be written in the Application inactive mode.	REAL
2	AO 1	-10.0 to +110.0%	0		
3	AO 3	-10.0 to +110.0%	0		
4	AO 4	-10.0 to +110.0%	0		

The value actually output from this module can be checked as a value ranging from 0 to 100%.

For details about relationship among the AO Status data (AO1 to AO2) and I / O variables used in the application program,

☞ refer to the appendix, Relationship among System Monitor Parameters and I / O variables (page A-App.- 9).

🏠 Note

- The values of AO1 to AO4 can be changed in Application inactive mode. The changed values are output directly.
- The values of AO1 to AO4 cannot be changed in Operating mode. The data read here shows the values of the corresponding I / O variables.

■ DI Status

The values of the digital inputs (DI1 to DI12) can be monitored.

Parameter type ID: 0E5h Group ID: 001h

Item ID	Item name	Setting range	User level	Remarks	Data type
1	DI 1	Not writable.	0	0:OFF 1:ON	BOOL
2	DI 2		0		
3	DI 3		0		
4	DI 4		0		
5	DI 5		0		
6	DI 6		0		
7	DI 7		0		
8	DI 8		0		
9	DI 9		0		
10	DI 10		0		
11	DI 11		0		
12	DI 12		0		

The values (ON / OFF) actually input to this module can be checked. For details about relationship among the DI Status data (DI1 to DI12) and I / O variables used in the application program,  refer to the appendix, Relationship Among System Monitor Parameters and I / O variables (page A-App.- 9).

■ DO Status

The values of the digital inputs (DO1 to DO16) can be monitored.

Parameter type ID: 0E6h Group ID: 001h

Item ID	Item name	Setting range	User level	Remarks	Data type
1	DO 1	0:OFF	0	The values can be written in Application inactive mode. The setting always becomes "0" while the TP is being used.	BOOL
2	DO 2	1:ON	0		
3	DO 3		0		
4	DO 4		0		
5	DO 5		0		
6	DO 6		0		
7	DO 7		0		
8	DO 8		0		
9	DO 9		0		
10	DO 10		0		
11	DO 11		0		
12	DO 12		0		
13	DO 13		0		
14	DO 14		0		
15	DO 15		0		
16	DO 16		0		

The values (ON / OFF) actually output to this module can be checked.

For details about relationship among the DO status data (DO1 to DO16) and I / O variables used in the application program, refer to the appendix, Relationship among System Monitor Parameters and I / O variables (page A-App.- 9).

Note

- The values of DO1 to DO16 can be changed in Application inactive mode. The changed values are output directly.
- The values of DO1 to DO16 cannot be changed in Operating mode. The data read here shows the values of the corresponding I / O variables.

Handling Precautions

The DO value of a channel that uses the digital output as time proportional output (TP output) always becomes "0" (OFF).

■ TP Status

When using the digital output as time proportional output, the TP output can be monitored.

Parameter type ID: 0E7h Group ID: 001h

Item ID	Item name	Setting range	User level	Remarks	Data type
1	TP 1	0.0 to 100.0%	0	The values can be written in the Application inactive mode. The setting always becomes "0.0" while the corresponding DO is being used.	REAL
2	TP 2	0.0 to 100.0%	0		
3	TP 3	0.0 to 100.0%	0		
4	TP 4	0.0 to 100.0%	0		
5	TP 5	0.0 to 100.0%	0		
6	TP 6	0.0 to 100.0%	0		
7	TP 7	0.0 to 100.0%	0		
8	TP 8	0.0 to 100.0%	0		
9	TP 9	0.0 to 100.0%	0		
10	TP 10	0.0 to 100.0%	0		
11	TP 11	0.0 to 100.0%	0		
12	TP 12	0.0 to 100.0%	0		
13	TP 13	0.0 to 100.0%	0		
14	TP 14	0.0 to 100.0%	0		
15	TP 15	0.0 to 100.0%	0		
16	TP 16	0.0 to 100.0%	0		

The values of the TP outputs (TP1 to TP16) can be monitored as values in % (percentage).

The value actually output from this module can be checked as a value ranging from 0 to 100%.

For details about relationship among the TP Status data (TP1 to TP16) and I / O variables used in the application program, refer to the appendix, Relationship among System Monitor Parameters and I / O variables (page A-App.- 9).

Note

- The values of TP1 to TP16 can be changed in Application inactive mode. The changed values are output directly.
- The values of TP1 to TP16 cannot be changed in Operating mode. The data read here shows the values of the corresponding I / O variables.

Handling Precautions

The TP value of a channel that uses the digital output as DO output (ON / OFF output) always becomes "0.0%".

■ Zener Barrier Adjustment Counts

This setup is specially designed for the high resolution type (CH40X / 20X). This setup is used to adjust the zener barrier when working with RTD.

Parameter type ID: 0E8h Group ID: 001h

Item ID	Item name	Setting range	User level	Remarks	Data type
1	Zener Barrier Adjustment Cnt1	Not writable.	1	For channel 1	REAL
2	Zener Barrier Adjustment Cnt2		1	For channel 2	
3	Zener Barrier Adjustment Cnt3		1	For channel 3	
4	Zener Barrier Adjustment Cnt4		1	For channel 4	

This setup is used to adjust the zener barrier when working with RTD.

For details about how to adjust the zener barrier,

☞ refer to the appendix, How to adjust the zener barrier (page A-App. - 14).

■ Front Port Active Communication Setup

The communication settings actually used for the front port can be checked.

Parameter type ID: 0F3h Group ID: 001h

Item ID	Item name	Setting range	User level	Remarks	Data type
1	Trans. Speed (OIT port)	Not writable.	0		DINT
2	Trans. Speed (loader port)		0		

■ Memory Usage Monitor

Parameter type ID: 103h

Group ID: 001h

Item ID	Item name	Setting range	User level	Remarks	Data type
1	Application Code Capacity	Not writable.	0	Size in bytes of compilation result of application program created by the user.	DINT
2	Application Code Usage		0		
3	Realtime Database Capacity		0	Size in bytes of ISaGRAF variables and FB instances	
4	Realtime Database Usage		0		
5	Online Modification1 Capacity		0	Unused.	
6	Online Modification1 Usage		0		
7	Online Modification2 Capacity		0	Unused.	
8	Online Modification2 Usage		0		
9	Application Symbols Capacity		0	Unused.	
10	Application Symbols Usage		0		
11	Retained Variables Capacity		0	Size in bytes of ISaGRAF retained variables	
12	Retained Variables Usage		0		
13	Non-sys Params Tab Capacity		0	The number of instances of Calculation Parameters, Calculation Monitor Parameters, Program Pattern Parameters, and User-defined Parameters	
14	Non-sys Params Tab Usage		0		
15	Non-sys Params Capacity		0	Size in bytes of Calculation Parameters, Calculation Monitor Parameters, Program Pattern Parameters, and User-defined Parameters	
16	Non-sys Params Usage		0		

The usage and capacity of the application code and Calculation Parameters can be checked.

For details,

☞ refer to the appendix, Downloading data and memory capacity (page A-App. - 16).

Chapter 8. DATA ADDRESSES

8 - 1 Data address structure

Data address to be used for the CPL communication is a 32-bit address and expressed in the hexadecimal notation.

The data address space consists of two areas, "Network Address (NA)" and "Parameter Address (PA)".

The CPL communication (Controller Peripheral Link) is Yamatake's host communication protocol.

■ About PA and NA

Data shown by the address is classified into two groups: "Variable" of ISaGRAF, and "Parameter" specially designed for DMC50. These are classified in the data address space as shown in the following table:

Data address area	Data class	Address classifications
00000000 to 0000FFFFh	Variable	Network Addresses (NA)
00010000 to FFFFFFFFh	Parameter	Parameter Addresses (PA)

Note

- The following classes of Parameters are provided:
 - System Parameters
 - System Monitor Parameters
 - Calculation Parameters
 - Calculation Monitor Parameters
 - Program Pattern Parameters
 - User-defined Parameters
- The user can create application programs for the CTRL module. Application programs can be created using "ISaGRAF workbench", a programming tool. In the application program, data can be defined freely as variables. Additionally, addresses that access to these variables through the communication can be defined (00000000 to 0000FFFFh). These addresses are called "Network Address (NA)".
- The data address space of the COM module has only the PA area.

■ Network Address (NA) structure

Network Address (NA) has the following structure:

0 0 0 0 **** h
(1) (2)

(1) Fixed at "0".

Upper 16 bits are always "0".

(2) NA

This represents Network Address (NA) that the user defines in application programs. This address consists of 16 bits and is expressed in hexadecimal notation.

■ Parameter Address (PA) structure

Parameter Address (PA) has the following structure:

*** *** ** h
(1) (2) (3)

(1) Parameter type ID

The Parameter type ID represents a specific No. to identify such as AI Setup, or PID_A Options. This ID consists of 12 bits and is expressed in hexadecimal notation in the data address list.

(2) Group ID

The group ID represents a channel No., PID group No. or etc. This ID consists of 12 bits and is expressed in hexadecimal notation in the data address list.

(3) Item ID

The item ID represents an item No. This ID consists of 8 bits and is expressed in hexadecimal notation.

● Example of data address

The PA of the System Alarms (item ID = 1) in the System Status (Parameter type ID = 0C1h) becomes "0C100101h".



Note

When viewed from hosts, variables and Parameters look the same. Variables and Parameters are only discriminated by their data address space.

8 - 2 Data address list (NA area)

The data address space of the NA area is "0 to 0000FFFFh".

The actually used data address area may depend on the Network Address (NA) allocated to the variables of the application program created by the user.

Handling Precautions

- The NA area can be accessed only in Operating mode and cannot be accessed in Application inactive mode.
- To access to the NA area through the CPL communication, assign Network Addresses to the target variables. When assigning the Network Addresses, the dictionary editor of the ISaGRAF workbench is used.
- The NA area exists only in the CTRL module and does not exist in the COM module.

8 - 3 Data address list (PA area)

The following table shows the data address list:

- Parameters are listed in order of address.
- The Parameter type ID and group ID are expressed in hexadecimal notation.
- For details about item IDs, refer to each parameter list.
- The "Read / Write" column shows the accessibility for the CPL communication. The following shows the meanings of the "Read / Write" column:

√ : Allowed

* : Allowed in Application inactive mode

Blank: Not Allowed

● System Parameters / System Monitor Parameters

Data address space	Parameter type ID	Group ID	Type label	Read	Write	Remarks
00100101 to 0010010D	001h	001h	H / W Info	√		
00200101 to 00200102	002h	001h	Date and Time Setup	√	√	
02100101 to 0210040D	021h	001 to 004h	AI Setup (High resolution type :standard inputs)	√	√	
02200101 to 0220040B	022h	001 to 004h	AI Setup (Special type)	√	√	
02300101 to 02300409	023h	001 to 004h	AI Setup (High resolution type :option inputs)	√	√	
04100101 to 04100206	041h	001 to 002h	AUX-IN Setup	√	√	
04500101 to 04500406	045h	001 to 004h	AO Setup	√	√	
06100101 to 06101003	061h	001 to 010h	DO Setup	√	√	
07100101 to 07101005	071h	001 to 010h	TP Setup	√	√	
07400101 to 07400104	074h	001h	Zener Barrier Adjustment Values	√	√	
0A300101 to 0A300101	0A3h	001h	Front Port Communication Setup	√		
0C100101 to 0C100103	0C1h	001h	System Status	√		
0C300101 to 0C300107	0C3h	001h	Date and Time Display	√		
0C400101 to 0C400131	0C4h	001h	System Alarm Log	√	√	
0C500101 to 0C500131	0C5h	001h	AI Alarm Log	√	√	
0C600101 to 0C600131	0C6h	001h	AUX-IN Alarm Log	√	√	
0E100101 to 0E100108	0E1h	001h	AI Status	√		
0E200101 to 0E200102	0E2h	001h	AUX-IN Status	√		
0E300101 to 0E300104	0E3h	001h	AO Status	√	*	
0E500101 to 0E50010C	0E5h	001h	DI Status	√		
0E600101 to 0E600110	0E6h	001h	DO Status	√	*	
0E700101 to 0E700110	0E7h	001h	TP Status	√	*	
0E800101 to 0E800104	0E8h	001h	Zener Barrier Adjustment Counts	√		
0F300101 to 0F300101	0F3h	001h	Front Port Active Communication Setup	√		
10300101 to 10300116	103h	001h	Memory Usage Monitor	√		

● Calculation Parameters / Calculation Monitor Parameters

Data address space	Parameter type ID	Group ID	Type label	Read	Write	Remarks
20100101 to 201FFF0C	201h	001 to FFFh	PID_A Options	√	√	
20200101 to 202FFF0C	202h		PID_A Constants	√	√	
20300101 to 203FFF0B	203h		PID_A Monitor	√		
21100101 to 211FFF0C	211h		PID_CAS Options	√	√	
21200101 to 212FFF0C	212h		PID_CAS Constants (master)	√	√	
21300101 to 213FFF0C	213h		PID_CAS Constants (slave)	√	√	
21400101 to 214FFF0B	214h		PID_CAS Monitor	√		
23400101 to 234FFF17	234h		Ra_PID Options	√	√	
23500101 to 235FFF0C	235h		Ra_PID Constants	√	√	
23600101 to 236FFF04	236h		Ra_PID Monitor	√		
24100101 to 241FFF0A	241h		UP_PID Options	√	√	
24200101 to 242FFF0B	242h		UP_PID Constants	√	√	
24300101 to 243FFF0C	243h		UP_PID Monitor	√		
30100101 to 301FFF28	301h		TBL / TBR Setup	√	√	

● Program Pattern Parameters

Data address space	Parameter type ID	Group ID	Type label	Read	Write	Remarks
C0000101 to C0006325	C00h	001 to 063h	Pattern Setup	√	√	
C0100101 to C6306334	C01 to C63h	001 to 063h	Segment Setup	√	√	
CF100101 to CF1FFF3A	CF1	001 to FFFh	Pattern FB Monitor	√		

● User-defined Parameters

Data address space	Parameter type ID	Group ID	Type label	Read	Write	Remarks
80100101 to 9FFFFFF3A	801 to 9FFh	001 to FFFh	Type label defined by the user	√	√	

! Handling Precautions

- Front Port Communication Setup cannot be changed through the CPL communication. This setting is changed from SLP-D50.
- Calculation Parameters, Calculation Monitor Parameters, Program Pattern Parameters, and User-defined Parameters can be accessed when they are already downloaded from the SLP-D50.
If such Parameters are not downloaded yet, they cannot be accessed since no data exists.

Chapter 9. MAINTENANCE AND TROUBLESHOOTING

■ Maintenance

● Cleaning

To remove the dirt and dust from the controller, clean it with a dry soft cloth rag.

● Part replacement

Only expert engineers are allowed to carry out the parts replacement work.

■ Troubleshooting

● System alarms related

Indication / Symptom	Possible Cause	When detected
The RUN LED flashes in red at intervals of 1 sec.	ROM error	Every time the power is turned ON.
The RUN LED is lit in red and the calibration data error alarm is generated.	Calibration data error	Every time the power is turned ON.
The RUN LED is lit in red and the board configuration error alarm is generated.	Board configuration error	Every time the power is turned ON.
The RUN LED is lit in red and the AI alarm is generated.	Analog input error	Every sampling time
The RUN LED is lit in red and the auxiliary input alarm is generated. (This alarm is generated only when the input type of the auxiliary input is DC voltage.)	Auxiliary input error	Every sampling time
The RUN LED is lit in red, the application code error occurs, and the application code is stopped.	Application code error	During operation (when the application is started.)
The RUN LED is lit in red and any of the System Parameter error, Non-sys Params Tab error, and Calculation Parameter error alarms occurs.	Parameter error	During operation
The POWER LED is lit in orange, the RUN LED is lit in red, and the battery voltage drop alarm occurs.	Battery voltage drop	During operation

Description	Corrective actions
It has been detected that an error has occurred in the system program stored in ROM. Since the operation of this module cannot be started, the loader communication cannot also be operated.	Contact Yamatake Corporation.
It has been detected that an error has occurred in the calibration data copied from the non-volatile memory to RAM. The CTRL module has the calibration data for the analog inputs, auxiliary inputs, and analog outputs.	Contact Yamatake Corporation.
Hardware (printed circuit board) combination not matching any valid module model has been detected.	Contact Yamatake Corporation.
Relevant analog input has exceeded the allowable input range due to faulty wiring. The allowable input range is -10 to +110% except for some ranges.	Check the analog input wiring or Input Type setting.
Relevant auxiliary input has exceeded the allowable input range due to faulty wiring. The allowable input range is -10 to +110% except for some ranges.	Check the auxiliary input wiring or Input Type setting.
No application code exist. It has been detected that an error has occurred in the application code created by the user, which has been stored in the backup RAM. It has been failed to download the application. The application cannot be executed.	Download the application again. If the same error occurs after the application has been downloaded again, contact Yamatake Corporation.
It has been detected that an error has occurred in the Parameters stored in the backup RAM.	Download the application again. If the same error occurs after the application has been downloaded again, contact Yamatake Corporation.
Voltage drop of the battery for backing up data in RAM has been detected.	DO NOT replace the battery yourself. Contact Yamatake Corporation.

● Loader communication related

Indication / Symptom	Possible Cause	When detected
SLP-D50 shows the error message, "Timeout", and the loader communication cannot be performed.	Power supply is faulty.	
	Loader cable connection is faulty.	
	Rotary switch setting is faulty.	During operation
	The module address setting on SLP-D50 is faulty.	During operation
	The communication path setting on SLP-D50 is faulty.	During operation
	The connector for the OIT communication is connected at the same time.	
SLP-D50 cannot be connected through the COM module.	Rotary switch settings are duplicated.	During operation

Description	Corrective actions
Power is not supplied to this module.	Check that the POWER LED is lit in green.If the POWER LED is not lit in green, this shows that power is not supplied.Supply power to this module correctly.
The loader cable for connecting this module and personal computer is not connected correctly.	Connect the loader cable correctly.
The rotary switch (module address setting) is set at "0" or at an intermediate position between numbers.	Set the rotary switch to a position other than "0" meeting the module address setting, and then turn ON the power again.
The module address setting of the project (this is set by selecting [Project Options] from the [Options] menu in SLP-D50) does not match the rotary switch setting on this module (Module Address setting).	Adjust the module address setting in SLP-D50 to the rotary switch setting.
The communication path setting in SLP-D50 (this is set using the [Project Options] of the [Options] menu) does not meet the actual communication path.	Adjust the communication path setting in SLP-D50 to the communication path to be connected actually.
Loader communication cannot be performed when the modular plug is plugged in the modular jack for the OIT(Operator Interface Terminal) communication.	Disconnect the modular plug.
Rotary switch settings (module address setting) on multiple CTRL modules linked to one COM module are duplicated.	Make the settings so that the rotary switch settings on the CTRL modules are not duplicated, and then turn ON the power again.

● Analog input related

Indication / Symptom	Possible Cause	When detected
An analog input value or auxiliary input value fluctuates greatly.	The FG terminal wiring of the 24V power supply is faulty.	During operation
	The shield line wiring is faulty.	During operation
	A terminal wire is loose.	During operation
	Control constants are set incorrectly.	During operation
	The Output Type is set incorrectly.	During operation
	The Time Proportioning Cycle is set incorrectly.	During operation
An analog input value or auxiliary input value does not change.	The Enable Input is set incorrectly.	During operation
	A sensor is faulty.	During operation
	The power supply to the sensor is faulty.	During operation
An option input value of the analog input does not change.	The standard input type is set incorrectly.	During operation

Description	Corrective actions
Since the FG terminal of the 24V power supply is not connected correctly, the noise adversely affects the module.	Connect the FG terminal of the 24V power supply to the grounding line of the user's equipment. If the fluctuation is still large after the above action has been taken, short circuit between the FG terminal of the 24V power supply and the (-) (negative) output terminal, with the FG terminal of the 24V power supply kept grounded.
Since the shielded cable is not used for the analog input or auxiliary input, or since the shield line is not connected correctly, the noise adversely affects the module.	Use the shielded cable and ground the shield line. If the fluctuation is still large after the above action has been taken, disconnect the shield line from the grounding line, and connect the shield line to the B terminal for the analog input or to the (-) (negative) terminal for the auxiliary input.
The wire is loose and the connection is loose.	Tighten the terminal screw firmly.
Since the control constants, such as PID constants are not appropriate, the control results are unstable.	Adjust the control constants to appropriate values.
Since the Output Type setting (current output or time proportional output) of the analog output used for the control output is not appropriate, the control results become unstable.	Set the Output Type of the analog output correctly.
Since the time proportioning cycle time of the output used for the control output is not appropriate, the control results become unstable.	Set the time proportioning cycle time appropriately.
The Enable Input setting of the analog input or auxiliary input is set at "False" (disabled).	Set the Enable Input setting of the analog input or auxiliary input to "True" (enabled).
The sensor is faulty.	Replace the sensor.
For the sensor needing a power supply, appropriate power is not supplied.	Supply power to the sensor.
The input type of the standard analog input is RTD or DC current.	Set the input type of the standard analog input to thermocouple or DC voltage.

Chapter 10. SPECIFICATIONS

■ General specifications

Item		Specifications		
Power supply	Power supply voltage	24Vdc ± 10%		
	Power ON inrush current	30 A / 50 μ s or less per module		
	Start-up time	10s or less (until the user application process is started.)		
	Power ON output	Digital output → Preset output value Analog current output → Maximum output current or less Analog voltage output → Maximum output voltage or less		
	Power OFF output	Digital output → Open Analog current output → Maximum output current or less Analog voltage output → Maximum output voltage or less		
	Insulation resistance	20MΩ or more between the power supply (24V) and isolated inputs / outputs and between the isolated inputs and outputs		
	Dielectric strength	500Vdc for 1 min. between the power supply (24V) and isolated inputs / outputs and between the isolated inputs and outputs		
	Current consumption	0.6 A or less		
	Power consumption	13 W or less		
	Battery life	10 years or longer under no power supply and standard conditions		
	Isolation	4-loop type		2-loop type
For analog inputs		4 blocks	For analog inputs	2 blocks
	For analog outputs	4 blocks	For analog outputs	2 blocks
	For auxiliary inputs	2 blocks	For auxiliary inputs	1 block
	For internal circuit, loader communication, and OIT communication	1 block	For internal circuit, loader communication, and OIT communication	1 block
	For backplane communication	1 block	For backplane communication	1 block
	12 isolation blocks in total		7 blocks in total	
External power supply	For digital inputs	2 blocks	For digital inputs	1 block
	For digital outputs	2 blocks	For digital outputs	1 block
Standard conditions	Ambient temperature	23°C ± 2°C		
	Ambient humidity	60% ± 5%RH (No condensation allowed)		
	Power supply voltage	24Vdc ± 2%		
	Vibration resistance	0 m / s ²		
	Shock resistance	0 m / s ²		
	Mounting angle	Reference plane ± 3°		
	Mounting conditions	Connector 1 and connector 2 are connected separately. A module is mounted alone.		
	Warm-up time	2 hrs. or longer		
	Burnout detection	Burnout current is set at "OFF" except for 3-wire RTD		
	Wiring resistance	1Ω or less		
	Ambient ventilation condition	To be installed in a place where the wind is minimized.		

Item		Specifications
Operating conditions	Operating ambient temperature	0°C to 50°C
	Ambient temperature for guaranteed accuracy	CTRL module (other than special type) 0°C to 50°C CTRL module (special type) 10°C to 40°C
	Ambient humidity	20% to 90%RH (No condensation allowed.)
	Vibration resistance	0.00 to 1.96 m / s ² (Panel mounting)
	Shock resistance	0.00 to 9.80 m / s ² (Panel mounting)
	Mounting angle	Reference plane ± 10°
	Approvals	EN61326-1-1997, AI-1998
Transport/Storage conditions	Ambient temperature	CTRL module (other than special type) -20°C to +70°C CTRL module (special type) 0°C to 50°C
	Ambient humidity	10% to 95%RH (No condensation allowed.)
	Vibration resistance	0.00 to 4.90 m / s ² (10 to 60 Hz for 2 hrs. each in X, Y, and Z directions)
	Shock resistance	0 to 490 m / s ² (3 times each for up and down)
	Package drop test	Drop height: 60 cm (1 angle, 3 edges, and 6 planes; free fall)
Other conditions	Maximum number of linkable modules	Up to eight CTRL modules linked to one COM module
	Mounting	Panel mounting or DIN rail mounting M3 screw (Tightening torque: 1.8 N • m)
	Terminal screw	M3.5 screw (Tightening torque: 0.78 to 0.98 N • m)
	Case material	Modified PPE, Glass 10%
	Terminal cover material	PC (Polycarbonate) resin
	Mass	600 g or less

■ Communication specifications

Item		Specifications
Backplane communication	Transmission line type	RS-485 compatible, 3-wire, bus type
	Mode	Half-duplex
	Synchronization method	Asynchronous communication
	Maximum cable length	20m max. (special cable needs to be used.)
	Terminating resistor	Not required.
	Connector	Special connector (Multilink connector)
Loader communication	Transmission line type	Special communication, one-to-one
	Mode	Half-duplex
	Synchronization method	Asynchronous communication
	Maximum cable length	2m max.(special cable needs to be used.)
	Transmission speed	9600 bps
	Connector	Communication with stereo mini-pin jack (special cable needs to be used.)
OIT(Operator Interface Terminal) communication	Operator interface terminal	EST-Zseries
	Transmission line type	RS-485 compatible, 3-wire, one-to-one
	Mode	Half-duplex
	Synchronization method	Asynchronous communication
	Maximum cable length	10m max.
	Terminating resistor	Not required.
	Transmission speed	9600 bps, 19200 bps, 38400 bps
	Bit length	8 bits
	Stop bit length	1 stop bit
	Parity bit	Even parity
	Connector	Special connector (Modular jack RJ-11: 4-pole and 4-core ← → Terminal)

■ Module types and input / output points

Item	DMC50CH40X	DMC50CH20X	DMC50CS40X	DMC50CS20X
Type	High resolution 4-loop	High resolution 2-loop	Special 4-loop	Special 2-loop
Number of analog input points	All ranges: 4 Specific ranges: 8	All ranges: 2 Specific ranges: 4	All ranges: 4	All ranges: 2
Number of analog output points	4	2	4	2
Number of auxiliary input points	2	1	2	1
Number of digital input points	12	6	12	6
Number of digital output points	16	8	16	8

■ Analog inputs

Item	DMC50CH40X	DMC50CH20X	DMC50CS40X	DMC50CS20X
Type	High resolution 4-loop	High resolution 2-loop	Special 4-loop	Special 2-loop
Input combination	* 1		* 2	
Input type	Universal inputs (Selected from thermocouple, RTD, or linear.)		Universal inputs (Selected from RTD or linear.)	
Input accuracy	$\pm 0.05\%$ FS or equivalent. (Unless otherwise specified particularly, the accuracy is 0 to 100% of the range. For details, refer to the range table.)		RTD: $\pm 0.1^\circ\text{C}$ or equivalent. Linear: $\pm 0.1\%$ FS or equivalent.	
Long-term stability (As a reference)	Equal to or less than 3 times the value of the ambient temperature effect per 1°C listed in the range table. (for 1st half year); Equal to or less than the value of the ambient temperature effect per 1°C listed in the range table. (per half a year, after the 1st half year)			
Input sampling time	The shortest sampling time is 50 ms.			
Influence of power supply	The specified accuracy is valid within the input power voltage range.			

* 1 Input type combinations for DMC50CH40X / CH20X

Standard input	Option input
Thermocouple	Thermocouple
Thermocouple	Linear voltage
Linear voltage	Thermocouple
Linear voltage	Linear voltage
RTD	N / A
Linear current	N / A

* 2 Input type combinations for DMC50CS40X / CS20X

Standard input	Option input
RTD	N / A
Linear voltage	N / A

● RTD

Item	DMC50CH40X	DMC50CH20X	DMC50CS40X	DMC50CS20X
Type	High resolution 4-loop	High resolution 2-loop	Special 4-loop	Special 2-loop
Input type	Refer to the below table of RTD ranges for high resolution type module.		Refer to the below table of RTD ranges for special type module.	
Accuracy				
Ambient temperature effect				
Resolution				
Measurement current	1.04 mA \pm 0.20 mA (The current flows from the "a" terminal for the 3-wire RTD while it flows from the "d" terminal for the 4-wire RTD.)		2.08 mA \pm 0.20 mA (The current flows from the "d" terminal.)	
Effect of wiring resistance	0.01%FS / Ω or less (The wiring resistance is in a range of 0 to 10 Ω .)		0.01 $^{\circ}$ C / Ω or less (The wiring resistance is in a range of 0 to 1 Ω .)	
Zener barrier	Possible only in a range from -200 to +500 $^{\circ}$ C		N / A	
Zener barrier resistance	70 Ω or less per wire.		N / A	
Wiring resistance	When the zener barrier is mounted and the range is F50 or F31, the resistance per wire is 10 Ω or less. When the zener barrier is not mounted and the range is F50, the resistance per wire is 80 Ω or less.		1 Ω or less per wire.	
Burnout indication	3-wire RTD: The burnout current is always ON. (fixed to upscale indication) 4-wire RTD: The burnout current is changed to ON or OFF by the setting.		4-wire RTD: The burnout current is changed to ON or OFF by the setting.	
Accuracy when burnout detection enabled	3-wire RTD: Within the specified input accuracy. 4-wire RTD: Within the specified input accuracy.		4-wire RTD: Within the specified input accuracy.	

[RTD ranges in centigrade for high resolution type module]

Range symbol	Range $^{\circ}$ C	Accuracy \pm $^{\circ}$ C (\pm %FS)	Ambient temperature effect \pm $^{\circ}$ C / $^{\circ}$ C *1 (\pm ppmFS / $^{\circ}$ C)	Minimum resolution $^{\circ}$ C
F50 Pt100	-200.0 to +500.0	0.35 (0.05)	0.020(29)	0.050
F31 Pt100	-60.00 to +100.00	0.15 (0.094)	0.010(63)	0.008

*1: The calculation is made assuming that the resistance per 1 $^{\circ}$ C is 0.39 Ω .

*2: Values in () are supplied as a reference only.

[RTD ranges in centigrade for special type module]

Range symbol	Range $^{\circ}$ C	Accuracy \pm $^{\circ}$ C	Ambient temperature effect \pm $^{\circ}$ C / $^{\circ}$ C	Minimum resolution $^{\circ}$ C
F Pt100	16.000 to 37.000	0.1	0.002	0.0002
F Pt100	-50.000 to +150.000	0.15	0.007	0.001

[Thermocouple ranges in centigrade for high resolution type module]

Range symbol	Range °C	Accuracy ± °C (±%FS)	Ambient temperature effect °C / °C *7 (±ppmFS / °C)	Minimum resolution °C	Electromotive force μV
K29 K:CA	-200.00 to +1200.00	0.7 (0.05)*1	0.08(46)	0.038	31.0 at -100°C
K24 K:CA	-200.00 to +400.00	0.3 (0.05)*1	0.04(56)	0.011	31.0 at -100°C
E08 E:CRC	0.00 to 800.00	0.4 (0.05)	0.04(39)	0.020	59.0 at 0°C
J08 J:IC	0.00 to 800.00	0.4 (0.05)	0.04(44)	0.024	50.0 at 0°C
U13 N:Nicr-Ni	0.00 to 1300.00	0.65 (0.05)	0.08(44)	0.045	26.0 at 0°C
Y13 PLII	0.00 to 1300.00	0.65 (0.05)	0.08(46)	0.039	29.8 at 0°C
T44 T:CC	-200.00 to +300.00	0.25 (0.05)	0.04(57)	0.012	29.0 at -100°C
B18 B:PR30-6	0.00 to 1800.00	1.8 (0.1)*2	0.12(71)	0.047*2	8.0 at 800°C
R16 R:PR13	0.00 to 1600.00	1.2 (0.075)*3	0.12(45)	0.041*3	7.0 at 100°C
S16 S:PR10	0.00 to 1600.00	1.2 (0.075)	0.12(51)	0.047	7.0 at 100°C
D19 PR40-20	0.00 to 1900.00	4.75 (0.25)*4	0.20(89)	0.147*4	2.2 at 800°C
W23 WRe5-26	0.00 to 2300.00	1.25 (0.05)	0.12(44)	0.095	13.5 at 0°C
W14 WRe5-26	0.00 to 1400.00	1.25 (0.09)	0.12(65)	0.095	13.5 at 0°C
Z07 DIN L	-200.00 to +800.00	0.5 (0.05)*5	0.08(59)	0.013	40.0 at -100°C
Z08 DIN U	-200.00 to +400.00	0.3 (0.05)*6	0.04(60)	0.026	40.0 at 0°C
Z13 Ni-NiMo	0.00 to 1300.00	1.3 (0.1)	0.08(46)	0.031	38.0 at 0°C

- *1: When the temperature is at or below -100°C, there exist differences in accuracy for K and T thermocouples; ±1.5°C for the range K29, ±0.6°C for the range K24, and ±0.5°C for the range T44.
- *2: When the B thermocouple is used, accuracy is ±72.0°C at or below 260°C, ±3.6°C over the range of 260 to 800°C, and undefined under 260°C.
- *3: When the R or S thermocouples is used, accuracy is ±1.6°C at or below 100°C.
- *4: When the PR40-20 thermocouple is used, accuracy is ±23.7°C at or below 300°C, ±14.2°C over the range of 300 to 800°C, and undefined under 300°C.
- *5: When the L thermocouple(DIN) is used, accuracy is ±0.75°C at or below -100°C.
- *6: When the U thermocouple(DIN) is used, accuracy is ±1.0°C at or below -100°C and ±0.5°C over the range of -100 to 0°C.
- *7: The ambient temperature effect (change from the standard ambient temperature: 23°C) is specified using the electromotive force / °C stated in the above table.
- *8: Values in () in the Accuracy column are provided as a reference. Values in () in the Ambient temperature effect column are provided as a reference. Effects on cold junction compensation are not included.

● Linear voltage

Item	DMC50CH40X	DMC50CH20X	DMC50CS40X	DMC50CS20X
Type	High resolution 4-loop	High resolution 2-loop	Special 4-loop	Special 2-loop
Input type	Refer to the below table of linear voltage ranges for high resolution type module.		Refer to the table of linear voltage ranges for special type module, on the next page.	
Accuracy				
Ambient temperature effect				
Resolution				
Input bias current	<p>The measurement is performed when the burnout detection is enabled and the input is short-circuited by a resistor of 250Ω:</p> <p>L02, M01: ± 0.2 μA or less</p> <p>L09, L01 : ± 2.0 μA or less</p> <p>Other than above: ± 8.0 μA or less</p> <p>The measurement is performed when the burnout detection is disabled and the input is short-circuited by a resistor of 250Ω:</p> <p>All ranges: ±10 nA or less</p>		<p>The measurement is performed when the burnout detection is enabled and the input is short-circuited by a resistor of 250Ω:</p> <p>L09, L01: ± 0.2 μA or less</p> <p>Other than above: ± 8.0 μA or less</p> <p>The measurement is performed when the burnout detection is made disabled and the input is short-circuited by a resistor of 250Ω:</p> <p>All ranges: ±10 nA or less</p>	
Effect of wiring resistance	<p>When the total wiring resistance is 250Ω, the influences on the input level are shown in the following:</p> <p>L02, M01: 50 μV or less</p> <p>L09, L01 : 500 μV or less</p> <p>Other than above: 2,000 μV or less</p>		<p>When the total wiring resistance is 250Ω, the influences on the input level are shown in the following:</p> <p>L09, L01: 400 μV or less</p> <p>Other than above: 2,000 μV or less</p>	
Input voltage range	-2V to +12V		-2V to +12V	
Burnout indication	Upscale or downscale can be selected by the setting.		Upscale or downscale can be selected by the setting.	
Allowable parallel resistance for burnout detection	<p>Measured when the burnout detection is enabled:</p> <p>L04, L08: 3 M Ω or more</p> <p>V01, L05, L07: 20 M Ω or more</p> <p>Other than above: 1 M Ω or more</p>		<p>Measured when the burnout detection is enabled:</p> <p>L04, L08 : 3 M Ω or more</p> <p>V01, L05, L07 : 20 M Ω or more</p> <p>Other than above : 1 M Ω or more</p>	

[Linear voltage ranges for high resolution type module]

Range symbol	Range	Accuracy ±%FS	Ambient temperature effect ±ppmFS / °C	Minimum resolution
L02	-10 to +10mV	0.07	60	1/72,000
M01	0 to 10mV	0.14	100	1/36,000
L09	-100 to +100mV	0.05	40	1/80,000
L01	0 to 100mV	0.10	80	1/40,000
L08	-1 to +1V	0.05	30	1/120,000
L04	0 to 1V	0.10	60	1/60,000
V01	1 to 5V	0.10	75	1/24,000
L05	0 to 5V	0.08	60	1/30,000
L07	0 to 10V	0.04	60	1/60,000

[Linear voltage ranges for special type module]

Range symbol	Range	Accuracy ±%FS	Ambient temperature effect ±ppmFS / °C	Minimum resolution
L09	-100 to +100mV	0.05	40	1/100,000
L01	0 to 100mV	0.10	80	1/40,000
L08	-1 to +1V	0.05	30	1/120,000
L04	0 to 1V	0.10	60	1/60,000
V01	1 to 5V	0.10	75	1/24,000
L05	0 to 5V	0.08	60	1/30,000
L07	0 to 10V	0.04	60	1/60,000

● **Linear current**

Item	DMC50CH40X	DMC50CH20X
Type	High resolution 4-loop	High resolution 2-loop
Input type	Refer to the below table of linear current ranges for high resolution type module.	
Accuracy		
Ambient temperature effect		
Resolution		
Input impedance	5 Ω ± 50% (Under the operating conditions)	
Input current range	28 mA or less	
Burnout indication	Burnout cannot be detected for the 0 to 20 mA range. (Burnout current is equivalent to 0 mA-input) -10% indication for the range of 4 to 20 mA	

[Linear current ranges for high resolution type module]

Range symbol	Range	Accuracy ±%FS	Ambient temperature effect ±ppmFS / °C	Minimum resolution
C08	0 to 20mA	0.04	100	1/40,000
C01	4 to 20mA	0.05	125	1/32,000

■ Analog output

Item	DMC50CH40X	DMC50CH20X	DMC50CS40X	DMC50CS20X
Type	High resolution 4-loop	High resolution 2-loop	Special 4-loop	Special 2-loop
Output type	Linear current output (0 to 20 mA, 4 to 20 mA) Linear voltage output (0 to 10V) Time proportional output with the load current setting feature(0 to 22 mA).			
Inrush current	30 mA, 50 ms or less			

● Linear current output

Item	DMC50CH40X	DMC50CH20X	DMC50CS40X	DMC50CS20X
Type	High resolution 4-loop	High resolution 2-loop	Special 4-loop	Special 2-loop
Output type	0 to 20 mA / 4 to 20 mA (The output type can be changed by the setting.)			
Output update time	Depends on the application: In Operating mode In Application inactive mode		Execution cycle time 100 ms	
Resolution	30,000 or more at an output of 0 to 20 mA 24,000 or more at an output of 4 to 20 mA			
Output accuracy	0 to 20 mA (However, if the output is 1.0 % or less, the accuracy is $\pm 0.5\%$ FS.) 4 to 20mA		$\pm 0.08\%$ FS $\pm 0.10\%$ FS	
Ambient temperature effect	0 to 20 mA 4 to 20mA		± 50 ppm $^{\circ}$ C or less ± 62 ppm $^{\circ}$ C or less	
Influence of power supply	$\pm 0.1\%$ (in a range of $24V \pm 10\%$)			
Ripple rate	$\pm 0.1\%$ FS or less during PWM cycle			
Allowable load resistance	500 Ω or less			
Open terminal voltage	20V or less			
Maximum output current	25 mA or less			
Output response time	50 ms (90% response time of step response from 0 to 100% or from 100 to 0%)			

● Linear voltage output

Item	DMC50CH40X	DMC50CH20X	DMC50CS40X	DMC50CS20X
Type	High resolution 4-loop	High resolution 2-loop	Special 4-loop	Special 2-loop
Output type	0 to 10V			
Output update time	Same as linear current output.			
Resolution	30,000 or more at an output of 0 to 10V.			
Output accuracy	± 0.1%FS (However, when the output is 1.0% or less, the accuracy is ± 0.5%FS.) With a load resistance of 100 k Ω or more			
Ambient temperature effect	± 50 ppm / °C or less			
Influence of power supply	± 0.1% (in a range of 24V ± 10%)			
Ripple rate	± 0.1% FS or less during PWM cycle			
Open terminal voltage	20V or less			
Maximum output current	40 mA or less			
Output response time	50 ms (90% response time of step response from 0 to 100% or from 100 to 0%)			

● Time proportional output

Item	DMC50CH40X	DMC50CH20X	DMC50CS40X	DMC50CS20X
Type	High resolution 4-loop	High resolution 2-loop	Special 4-loop	Special 2-loop
Output type	Time proportional output with current level setting feature			
Resolution	1,000			
Output cycle time	1s to 120s (in increments of 1s)			
Cycle time accuracy	± 0.1% ± 2 ms (to the output cycle)			
Current output accuracy	± 50 μA			
Maximum output voltage	20V or less			
Maximum output current	40 mA or less			
Output response time	500 μ s or less when the output is turned OFF with a load of 500 Ω. 1000 μ s or less when the output is turned ON with a load of 500 Ω.			
Output update	If the MV value is changed within a time proportional output cycle, the output can be turned ON or OFF regardless of the updating timing.			
Allowable load resistance	500 Ω or less			
Current level setting range	0 to 22 mA			

■ Auxiliary input

Item	DMC50CH40X	DMC50CH20X	DMC50CS40X	DMC50CS20X
Type	High resolution 4-loop	High resolution 2-loop	Special 4-loop	Special 2-loop
Number of input points	2 points	1 point	2 points	1 point
Input type	AC input or DC input: Change between them requires redoing the parameter setting and rewiring to the designated terminals.			
Input sampling time	100 ms			
Influence of power supply	The specified accuracy is met while the supplied power is within the specified power supply voltage range.			

● AC input

Item	Specifications
Input type	0 to 5V, 0 to 6V, 0 to 10V, or 0 to 12V can be selected by the setting.
Input accuracy	0 to 12Vac $\pm 1.25\%FS$ 0 to 6Vac $\pm 2.5\%FS$ 0 to 10Vac $\pm 1.5\%FS$ 0 to 5V ac $\pm 3.0\%FS$
Ambient temperature effect	Not specified. (For reference : ± 500 ppm FS / °C at 0 to 12Vac)
Input bias current	2 μA or less when the input is short-circuited by a resistor of 250 Ω . (Provided as a reference)
Effect of wiring resistance	40 mV or less as the input level corresponding to the indicated value, in those cases where the total wiring resistance is 250 Ω . (Provided as a reference)
Input voltage range	14.4Vac or less
Resolution	0 to 12Vac 1200 or more (The resolution is 0.2Vac when "20:1" transformer is used.) 0 to 10Vac 1000 or more (The resolution is 0.2Vac when "20:1" transformer is used.) 0 to 6Vac 600 or more (The resolution is 0.2Vac when "20:1" transformer is used.) 0 to 5Vac 500 or more (The resolution is 0.2Vac when "20:1" transformer is used.)
Input impedance	100 k Ω (under the operating conditions)
Burnout indication	% value corresponding to 0Vac input

● DC input

Item	Specifications
Input type	1 to 5Vdc
Input accuracy	$\pm 0.2\%FS$
Ambient temperature effect	Not specified. (For reference : ± 300 ppm FS / °C)
Input bias current	8 μA or less when the input is short-circuited by a resistor of 250 Ω . (Provided as a reference)
Effect of wiring resistance	2000 μV as the input level corresponding to the indicated value, in those cases where the total wiring resistance is 250 Ω . (Provided as a reference)
Input voltage range	-1Vdc to +6Vdc
Resolution	1/2500 or more
Input impedance	1 M Ω or more (under the operating conditions)
Burnout indication	Upscale

■ Digital input

Item	DMC50CH40X	DMC50CH20X	DMC50CS40X	DMC50CS20X
Type	High resolution 4-loop	High resolution 2-loop	Special 4-loop	Special 2-loop
Number of input points	12 points	6 points	12 points	6 points
Input type	Photo-coupler input (bi-direction)			
Connectable output	Voltage source + contact			
ON voltage	15.0 V / 0.9 mA or more			
OFF voltage	7.0 V or less			
OFF current	0.4 mA or less			
Input voltage	24V ± 10%			
Current limit resistance	15 k Ω ± 5%			
Sampling time	Depends on the application In Operating mode : Execution cycle time In Application inactive mode : 100 ms			
Minimum Detectable Pulse Width	Depends on the application In Operating mode : Execution cycle time or longer In Application inactive mode : 100 ms or longer			
Terminal	6-points common (Common lines on both source side and sink side are possible.)			

■ Digital output

Item	DMC50CH40X	DMC50CH20X	DMC50CS40X	DMC50CS20X
Type	High resolution 4-loop	High resolution 2-loop	Special 4-loop	Special 2-loop
Number of output points	16 points	8 points	16 points	8 points
Output type	Open-drain type FET output			
ON-state residual voltage	1.5V or less			
ON voltage	1.5V or less			
OFF-state leakage current	100 μ A or less			
Maximum output current	70 mA / point. However, 400 mA or less per 8 points (1 common)			
Applied voltage range	10.8V to 26.4V			
Input bias voltage	10.8V to 26.4V			
Connector pins	Input bias, common on the sink side: bias and common pins assigned per 8 output points			
Over-current protection	None			
Operation	Operating mode		Turned ON and OFF by application	
	Application inactive mode		Turned ON and OFF by preset output value setting.	

■ Outside dimensions

Unit: mm

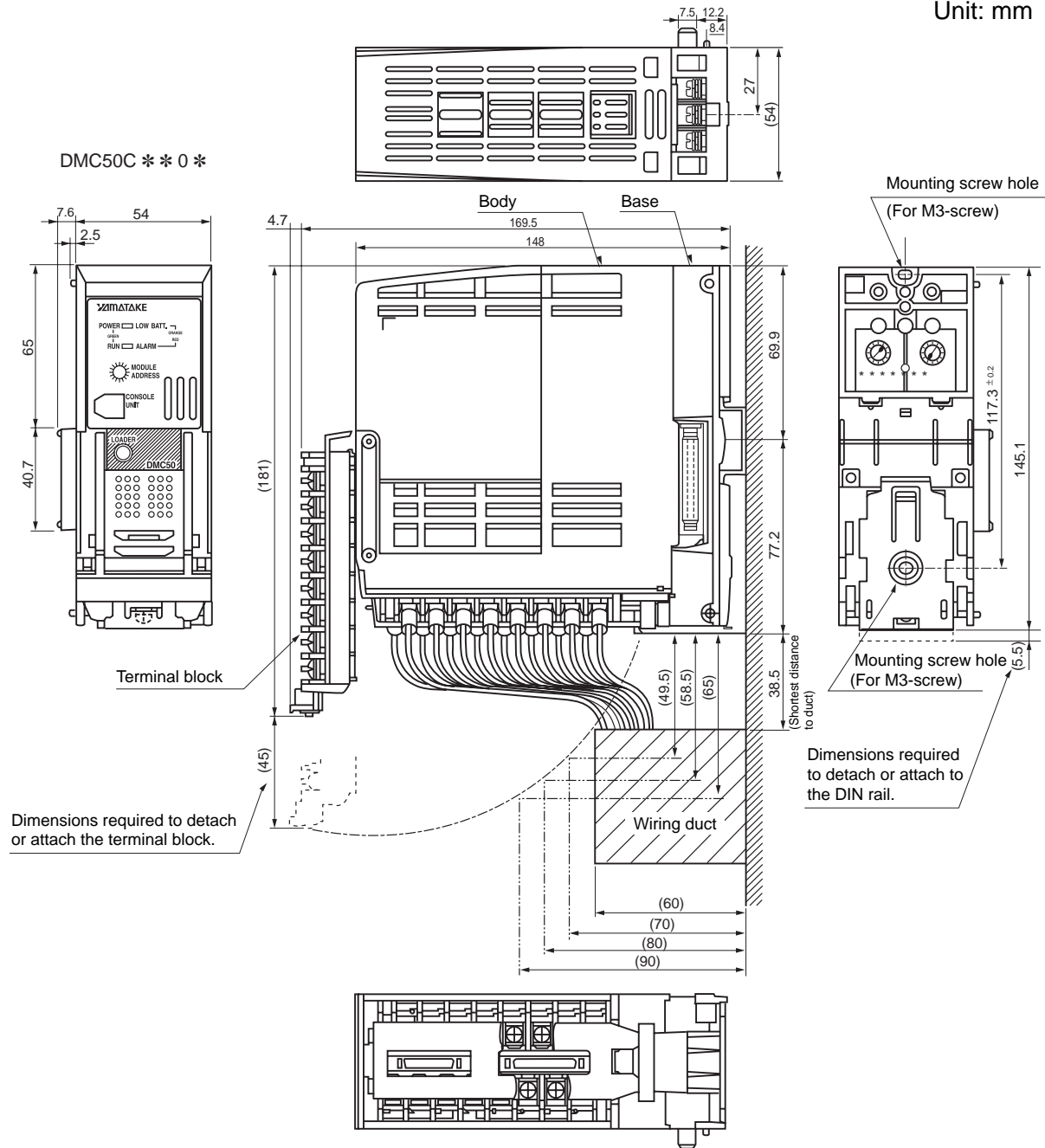

APPENDIX

System Status bit data

This System Status is 32-bit data showing the alarm status of this module.

The following describes the details of the System Alarms, AI Alarms, and AUX-IN Alarms bit data:

■ System Alarms

Bit	Alarm name	When detected	Description	Corrective actions
0	Calibration data error	Every time the power is turned ON.	<ul style="list-style-type: none"> It has been detected that an error has occurred in the calibration data copied from non-volatile memory to RAM. The CTRL module has the calibration data for the analog input, auxiliary input, and analog output. 	Contact Yamatake Corporation.
1	System Parameter error	During operation	<ul style="list-style-type: none"> The System Parameters backed up in memory have been corrupted. 	<ul style="list-style-type: none"> Download the application again. If the same error occurs after the application has been downloaded again, contact Yamatake Corporation.
2	Calculation Parameters table error	During operation	<ul style="list-style-type: none"> The management table used to administer the storage locations of the Calculation Parameters, Calculation Monitor Parameters, and User-defined Parameters has been corrupted. 	
3	Calculation Parameter error	During operation	<ul style="list-style-type: none"> The Calculation Parameters, Calculation Monitor Parameters, and User-defined Parameters backed up in memory have been corrupted. 	
4	Application code error	Every time the power is turned ON or the application is started.	<ul style="list-style-type: none"> No application code exist. The application code created by the user, which has been backed up in memory, is corrupted. Memory capacity for the application is insufficient. It has been failed to download the application. *1 	
5	Reserved.			
6	Reserved.			
7	Reserved.			
8	A / D1 fault	Every sampling time *2	<ul style="list-style-type: none"> *The A / D converter has been faulty. 	Contact Yamatake Corporation.
9	A / D2 fault	Every sampling time *2		
10	A / D3 fault	Every sampling time *2		
11	A / D4 fault	Every sampling time *2		

Bit	Alarm name	When detected	Description	Corrective actions
12	AI alarm summary	Every sampling time *2	•There is one or more inputs that are outside the allowable input range due to faulty wiring or the like. (-10 to +110% of each input range except for some ranges is an allowable input range.)	•Check the contents of the AI alarm to locate a faulty input channel. •Check the analog input wiring or input type setting.
13	AUX-IN alarm summary	Every sampling time *2	•This alarm is generated only when the input type of the auxiliary input is the DC voltage. •There is one or more inputs that are outside the allowable input range due to faulty wiring or the like. (-10 to +110% of each input range except for some ranges is an allowable input range.)	•Check the contents of the AUX-IN alarm to locate a faulty input channel. •Check the auxiliary input wiring or input type setting.
14	Reserved.			
15	Reserved.			
16	Board configuration error	Every time the power is turned ON.	•Hardware (printed circuit board) combination does not correspond to any valid module model.	•Contact Yamatake Corporation.
17	Battery voltage drop	Every sampling time *2	•Voltage drop of the battery for backing up data in RAM has been detected.	•DO NOT replace the battery yourself. •Contact Yamatake Corporation.
18 to 31	Reserved.			

*1: Error detection is not performed immediately after it has been failed to download the application. When the application is started after that, error detection is performed.

*2: The sampling time is 100 ms. (When the mode is Application operating mode, the sampling time is equivalent to the cycle time.)



Note

- If any system alarm is generated, the RUN LED on the front panel of this module is lit in red.
- The alarm generation / reset history can be checked viewing System Alarm Log Parameter.

■ AI Alarms

Bit	Alarm name	Description	Corrective actions
0	AI1 over-range	•AI1 is above 110% of the range.	•Check the analog input wiring or the Input Type setting.
1	AI1 under-range	•AI1 is below -10% of the range.	
2	AI1 setting error	•Invalid Input Type setting for AI1.	
3	Reserved.		
4	AI2 over-range	•AI2 is above 110% of the range.	•Check the analog input wiring or the Input Type setting.
5	AI2 under-range	•AI2 is below -10% of the range.	
6	AI2 setting error	•Invalid Input Type setting for AI2	
7	Reserved.		
8	AI3 over-range	•AI3 is above 110% of the range.	•Check the analog input wiring or the Input Type setting.
9	AI3 under-range	•AI3 is below -10% of the range.	
10	AI3 setting error	•Invalid Input Type setting for AI3	
11	Reserved.		
12	AI4 over-range	•AI4 is above 110% of the range.	•Check the analog input wiring or the Input Type setting.
13	AI4 under-range	•AI4 is below -10% of the range.	
14	AI4 setting error	•Invalid Input Type setting for AI4	
15	Reserved.		
16	Option AI1 over-range	•Option AI1 is above 110% of the range.	•Check the analog input wiring or the Input Type setting.
17	Option AI1 under-range	•Option AI1 is below -10% of the range.	
18	Option AI1 setting error	•Invalid Input Type setting for Option AI1 •The option input is used when the RTD or DC current range is used for the standard input.	
19	Reserved.		
20	Option AI2 over-range	•Option AI2 is above 110% of the range.	•Check the analog input wiring or the Input Type setting.
21	Option AI2 under-range	•Option AI2 is below -10% of the range.	
22	Option AI2 setting error	•Invalid Input Type setting for Option AI2. •The option input is used when the RTD or DC current range is used for the standard input.	

Bit	Alarm name	Description	Corrective actions
23	Reserved.		
24	Option AI3 over-range	•Option AI3 is above 110% of the range.	•Check the analog input wiring or the Input Type setting.
25	Option AI3 under-range	•Option AI3 is below -10% of the range.	
26	Option AI3 setting error	•Invalid Input Type for Option AI3. •The option input is used when the RTD or DC current range is used for the standard input.	
27	Reserved.		
28	Option AI4 over-range	•Option AI4 is above 110% of the range.	•Check the analog input wiring or the Input Type setting.
29	Option AI4 under-range	•Option AI4 is below -10% of the range.	
30	Option AI4 setting error	•Invalid Input Type for Option AI4. The option input is used when the RTD or DC current range is used for the standard input.	
31	Reserved.		



Note

- The alarms related to the option AI occur only in the high resolution type (CH40X / 20X).
- When the input is set at "Disabled" in the AI Setup, no alarms occur in relevant channel.
- If any AI alarm is generated, the RUN LED on the front panel of this module is lit in red.
- The alarm generation / reset history can be checked by viewing AI Alarm Log Parameter

■ AUX-IN Alarms

Bit	Alarm name	Description	Corrective actions
0	AUX-IN1 over-range	•AUX-IN1 is above 110% of the range.	•Check the auxiliary input wiring or the Input Type setting.
1	AUX-IN1 under-range	•AUX-IN1 is below -10% of the range.	
2	Reserved.		
3	Reserved.		
4	AUX-IN2 over-range	•AUX-IN2 is above 110% of the range.	•Check the auxiliary input wiring or the Input Type setting.
5	AUX-IN2 under-range	•AUX-IN2 is below -10% of the range.	
6 to 31	Reserved.		

Note

- The AUX-IN alarm is generated only when the input type is the DC voltage range.
- If an input is set at "Disabled" in the AUX-IN Setup, no alarms will be generated in relevant channel.
- If any AUX-IN alarm is generated, the RUN LED on the front panel of this module is lit in red.
- The alarm generation / reset history can be checked viewing AUX_IN Alarm Log Parameter

Logging capability

■ About logging capability

This module automatically performs logging of three data: status code, year / month / day, and hour / minute / second of alarm generation / reset of the System Status (System Alarms, AI Alarms, and AUX-IN Alarms). Each alarm record is logged into the corresponding Log Parameter (System Alarm Log, AI Alarm Log and AUX_IN Alarm Log, respectively). By reading these data, the alarm log can be checked.

■ Update time and the number of logging records

- The logging capability is always active.
- Newest 16 occurrences of alarm record are stored. The log data is updated through the ring buffer structure. The latest record is judged by the latest log number and time stamp. (The record is not sorted automatically by the time stamp.)
- Status change of alarms is checked at intervals of the cycle time in Operating mode and at intervals of 100 ms in Application inactive mode. At that time, if the alarm data becomes different from the previously logged alarm data, it is determined that a new alarm has been generated or the alarm has been reset, and then the alarm log is updated automatically.
- As the log is updated, the value of the latest log number increments and relevant record containing status code, year / month / day, and hour / minute / second items are added automatically.
- To clear the log data, write "0" to [Latest Log Number]. As the value is set to "0", all the [Contents], [Year / Month / Day], and [Hour / Min / Sec] items of 16 records are cleared to "0".

ISaGRAF variables and Parameter data types

■ ISaGRAF variable data types

The following shows the ISaGRAF variable data types:

Data type	Contents	Range
BOOL	Boolean value	0 to 1 (0: FALSE, 1: TRUE)
DINT	Double-precision integer	-2147483647 to +2147483647
REAL	Real number	Approximately 10^{-38} to 10^{38} (Precision of maximum 7-digit decimal number)
TIME	Time type data	0 - T#23h59m59s999ms
STRING*	Character string	Up to 255 byte characters with variable length

* This data cannot be accessed through the CPL communication.

Note

- The ISaGRAF variables are available only on the CTRL module and not available on the COM module.
- Data type of each variable is defined and decided using the dictionary editor of the ISaGRAF workbench when an application program is created.
- BOOL type is also called "Boolean type" in ISaGRAF.
- DINT type is 32-bit signed integer data, which is also called "integer type" in ISaGRAF. Note that the range is started from "-2147483647".
- REAL type is 32-bit floating-point (single-precision) data in conformity with IEEE754, which is also called "real number type" in ISaGRAF.
- TIME type is 32-bit unsigned integer data (unit: ms), which is also called "timer type" in ISaGRAF.
- STRING type is called "Message type" (or character string type) in ISaGRAF. This data cannot be accessed through the CPL communication.

■ Parameter data types

The following shows the data types of Parameter elements, which are data specially designed for this instrument:

Data type	Contents	Range
BOOL	Boolean value	0 to 1 (0: FALSE, 1: TRUE)
DINT	Double-precision integer	-2147483647 to +2147483647
DWORD	32-bit binary data	0 to FFFFFFFFh
REAL	Real number	Approximately 10^{-38} to 10^{38} (7-digit precision)

 **Note**

- The following Parameters are provided:
 - System Parameters
 - System Monitor Parameters
 - Calculation Parameters
 - Calculation Monitor Parameters
 - Program Pattern Parameters
 - User-defined Parameters
- Data type of each Parameter item, can be found in the relevant Parameter table.
- DINT type is 32-bit signed integer data. Note that the range is started from "-2147483647".
- DWORD type is 32-bit data. This data is normally used to handle binary images, such as bit data.
- REAL type is 32-bit floating-point (single precision) data in conformity with IEEE 754.

Relationship among System Monitor Parameters and I / O variables

The following describes the relationship among the System Monitor Parameters (AI Status, AUX-IN Status, AO Status, DI Status, DO Status, and TP Status) and I / O variables (input variables and output variables) used in the application program:

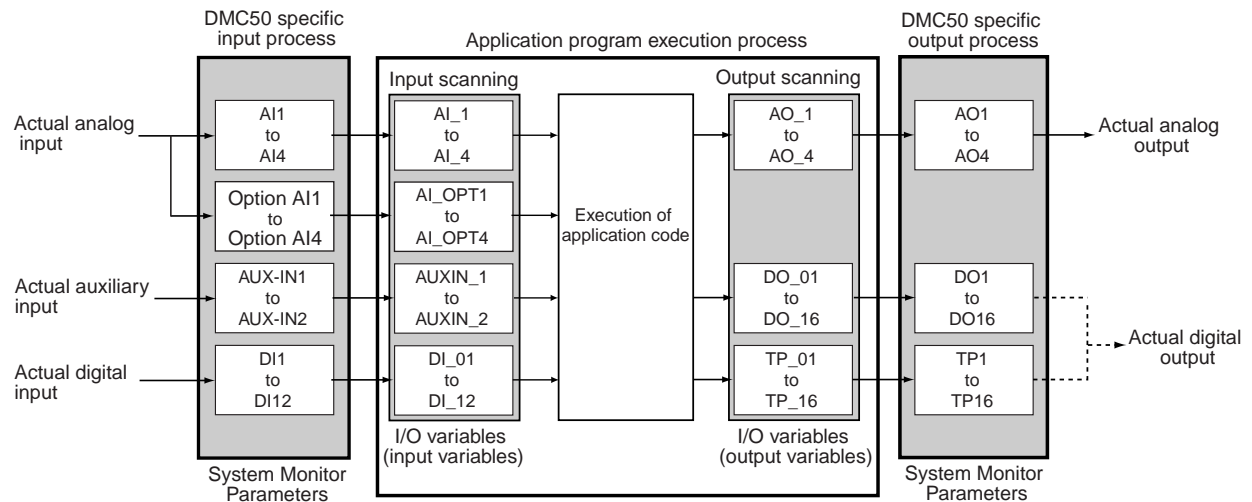

■ About System Monitor Parameters

- System Monitor Parameters are DMC50 specific input / output data and are always provided.
- The input data (AI1 to AI4, option AI1 to option AI4, AUX-IN1 to AUX-IN2, and DI1 to DI12) always show the actual input values.
- The output data (AO1 to AO4, DO1 to DO16, TP1 to TP16) always show the values to be output actually.

■ About I / O variables

- I / O variables are data to be used for an application program created by the user and exist only in Operating mode.
- I / O variables are divided into input variables and output variables. Normally, values in the I / O variables are actually input or output. However, when using the I / O variable lock feature and virtual I / O feature, the I / O variables can be separated from the physical I / O.

■ Analog inputs (AI1 to AI4, option AI1 to option AI4)

The following shows the relationship among the System Monitor Parameter (AI Status) and I / O variables:

System Monitor Parameter	I / O variable names (input variables)
AI1 to AI4	AI_1 to AI_4
Option AI1 to Option AI4	AI_OPT1 to AI_OPT4

- In Operating mode, the System Monitor Parameter (AI Status) element values are the same as the corresponding I / O variable values. However, when using the I / O variable lock feature and virtual I / O feature, they may be different. Here, the System Monitor Parameter (AI Status) shows the actual input values and the I / O variables show the virtual values.

■ Auxiliary inputs (AUX-IN1 to AUX-IN2)

The following shows the relationship among the System Monitor Parameter (AUX-IN Status) and I / O variables:

System Monitor Parameter	I / O variable names (input variables)
AUX-IN1 to AUX-IN2	AUXIN_1 to AUXIN_2

- In Operating mode, the System Monitor Parameter (AUX-IN status) element values are the same as the corresponding I / O variable values.
- However, when using the I / O variable lock feature and virtual I / O feature, they may become different. Here, the System Monitor Parameter (AUX-IN status) shows the actual input values and the I / O variables show the virtual values.

■ Analog outputs (AO1 to AO4)

The following shows the relationship among the System Monitor Parameter (AO Status) and I / O variables:

System Monitor Parameter	I / O variable names (input variables)
AO1 to AO4	AO_1 to AO_4

- In Operating mode, the System Monitor Parameter (AO Status) element values are the same as the corresponding I / O variable values. However, when using the I / O variable lock feature and virtual I / O feature, they may become different.
- When using the I / O variable lock feature, the System Monitor Parameter (AO Status) shows the values to be output actually (values desirably changed with the variable lock) and the I / O variables show the values on the application program.
- When using the virtual I / O capability, the System Monitor Parameter (AO Status) shows the values to be output actually (normally, 0.0%) and the I / O variables show the values on the application program.

■ Digital inputs (DI1 to DI12)

The following shows the relationship among the System Monitor Parameter (DI Status) and I / O variables:

System Monitor Parameter	I / O variable names (input variables)
DI1 to DI12	DI_01 to DI_12

- In Operating mode, the System Monitor Parameter (DI Status) element values are the same as the corresponding I / O variable values. However, when using the corresponding I / O variable lock feature and virtual I / O feature, they may be different. Here, the System Monitor Parameter (DI Status) shows the actual input values and the I / O variables show the virtual values.

■ Digital outputs (DO1 to DO16, TP1 to TP16)

The following shows the relationship among the System Monitor Parameters (DO Status and TP Status) and I / O variables:

System Monitor Parameter	I / O variable names (input variables)
DO1 to DO16	DO_01 to DO_16
TP1 to TP16	TP_01 to TP_16

- In Operating mode, the System Monitor Parameters (DO Status and TP Status) element values are the same as the I / O variable values. However, when using the I / O variable lock feature and virtual I / O feature, they may become different.
- When using the I / O variable lock feature, the System Monitor Parameters (DO Status and TP Status) show the values to be output actually (values desirably changed with the variable lock) and the I / O variables show the values on the application program.
- When using the virtual I / O feature, the System Monitor Parameters show the values to be output actually (normally, the DO Status is 0 and TP Status is 0.0%) and the I / O variables show the values on the application program.

Note

Selecting [Output Type] of [DO Setup] in the System Parameters decides which I/O variable value is reflected on the actual output for the specified channel: the DO variable(DO1 to DO16) or the TP variable (TP1 to TP16), both for the same channel, used in the application program. The following shows each behavior in Operating mode:

Output type	System Monitor Parameters	I / O variables (output variables)
DO output	DO value = Same as I / O variable TP value = Fixed at 0.0%	DO value and TP value are desired values assigned in the application program.
TP output	DO value = Fixed at 0. TP value = Same as I / O variable.	

Burnout indication

■ Analog inputs

The tables below describe the actual burnout indication behaviors common to the high resolution type (CH40X / 20X) and special type (CS40X / 20X). However, the supported input type may vary.

● When "Disable Burnout Current" is set to False (Enabled burnout current):

Input Type	Actual behavior status of [Burnout Indication]	
	Upscale setting	Downscale setting
Thermocouple	Upscale	Downscale
Linear DC voltage	Upscale	Downscale
Linear DC current (0 to 20 mA)	Around 0%FS	
Linear DC current (4 to 20 mA)	Fixed at downscale.	
RTD (3-wire RTD)	Fixed at upscale.	
RTD (4-wire RTD)	Fixed at upscale.	

● When "Disable burnout current" is set to True:

Input Type	Actual behavior status of [Burnout Indication]	
	Upscale setting	Downscale setting
Thermocouple	N / A (Burnout cannot be detected.)	
Linear DC voltage	N / A (Burnout cannot be detected.)	
Linear DC current (0 to 20 mA)	Around 0%FS	
Linear DC current (4 to 20 mA)	Fixed at downscale.	
RTD (3-wire RTD)	Fixed at upscale.	
RTD (4-wire RTD)	N / A (Burnout cannot be detected.)	

! Handling Precautions

- When "Disable burnout current" is set to True, the Burnout Indication setting becomes invalid and the actual burnout indication behavior is predetermined as in the above table.
- The upscale is 110%FS and the downscale is -10%FS. However, the low limit of the AI value becomes -210°C for the RTD (range No. 21: -200 to +500°C).
- In RTD (3-wire RTD) and linear DC current ranges, the "Disable burnout current" setting becomes invalid and the actual burnout indication behavior is predetermined as in the above table. (The operation is always performed as "Disable burnout current" set to False (burnout is detected.).)
- For the linear DC current (0 to 20 mA), the burnout cannot be detected.
- For RTD (4-wire RTD), burnout indication is fixed to downscale if the D line has faulty wiring.

■ Auxiliary inputs

The following describes the actual burnout indication behaviors common to the high resolution type (CH40X / 20X) and special type (CS40X / 20X):

Input type	Operation
Setting 0:AC voltage (5V reference)	Around 0%
Setting 1:AC voltage (6V reference)	Around 0%
Setting 2:AC voltage (10V reference)	Around 0%
Setting 3:AC voltage (12V reference)	Around 0%
Setting 4:DC voltage	Upscale

How to adjust the zener barrier

When the RTD input is combined with the zener barrier, this module needs to be adjusted in order to correct fluctuations in resistance value of the zener barrier.

When using the zener barrier, the following adjustment must be carried out:

■ Conditions allowing adjustment and correction of zener barrier

The zener barrier can be adjusted, corrected, and operated only when 3-wire RTD (range No. 21: -200 to +500°C) is used with the high resolution type (CH40X / 20X) module.

■ How to adjust the zener barrier

- (1) Set [Input type] of the AI Setup to "21" (RTD -200 to +500°C range) and [RTD 3 / 4-wire change] to [3-wire RTD] for a input channel.
- (2) Turn OFF the power and perform the wiring as shown in the Figure below. (Short circuit the A and B wires at the terminal part of the RTD sensor.)

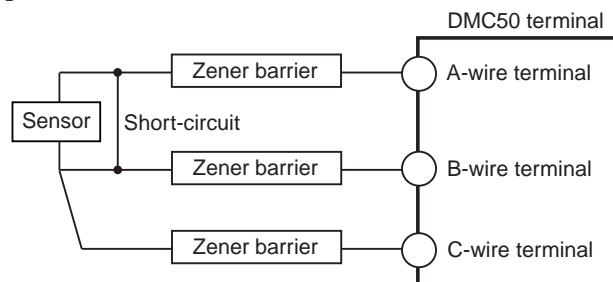

- (3) Read the difference between the resistance values of the zener barriers respectively connected to the A and B wires as [Zener Barrier Adjustment Counts] in the System Monitor Parameters.
- (4) Write these zener barrier adjustment counts to [Zener Barrier Adjustment Values] as adjustment values.
- (5) Turn OFF the power to this module and remove the short-circuit between the A and B wires.
- (6) Repeat the above steps (1) to (5) for necessary channels.

! Handling Precautions

- The zener barrier can be used only when 3-wire RTD (range No. 21: -200 to +500°C) is used with the high resolution type (CH40X / 20X) module.
- Always adjust the difference between the resistance values of the zener barriers connected to the A and B wires to 80 Ω or less.
If this difference is 80 Ω or more, the zener barrier cannot be adjusted.
- Always use the zener barrier having a DC resistance value of 70 Ω or less.
- Once the zener barrier is adjusted, the correction is always performed for that zener barrier. When using the RTD sensor without zener barrier, write "0" to [Zener barrier adjustment value]. This makes no zener barrier correction.

AO, DO, and TP preset / bumpless operation

It is possible to specify output value for AO, DO, and TP when the operation transits between Operating mode and Application inactive mode, and those when the power is turned ON. The setting can be set individually for each channel:

■ [Output Not in Operating Mode] is set at [Preset Output Value].

When any of the following conditions is satisfied, the value stored in [Preset Output Value] is output:

- The mode is changed from Operating mode to Application inactive mode.
- The mode is changed from Application inactive mode to Operating mode.
(When the application program is executed for the first time, the corresponding I / O variable is set by this Preset Output Value as its initial value.)
- The mode is Application inactive mode immediately after the power has been turned ON.
- The mode is Operating mode immediately after the power has been turned ON.
(When the application program is executed for the first time, the corresponding I / O variable is set with this Preset Output Value as its initial value.)

■ [Output Not in Operating Mode] is set at [Bumpless Transfer].

When any of the following conditions is satisfied, the value saved before changing is output:

- The mode is changed from Operating mode to Application inactive mode.
(The last output value by the application program is output continuously.)
- The mode is changed from Application inactive mode to Operating mode.
(The last output value in Application inactive mode becomes the initial value of the I / O variable when the application program is executed for the first time.)
- The mode is the Application inactive mode immediately after the power has been turned ON.
(The last output value before the power failure occurs is output.)
- The mode is Operating mode immediately after the power has been turned ON.
(The last output value before the power failure occurs becomes the initial value of the I / O variable when the application program is executed for the first time.)

! Handling Precautions

The following shows the intended uses of bumpless output transfer:

- To sustain the output when the application program is downloaded.
- To sustain the output when the power to the controller is turned OFF in Operating mode, until it is turned ON again.

However, complete bumpless operation cannot be obtained depending on the logic of the application program. The data during execution of the application program cannot be backed up completely ;therefore, it is not possible to automatically resume the application program completely.

Downloading data and memory capacity

The size of the application program or Calculation Parameters to be downloaded to this module is limited by the memory capacity of this module. The following describes these memory capacities:

Note

The following describes the memory capacity of the data to be downloaded to the CTRL module:

This description does not apply to the COM module.

■ Download size list

The following list describes data to be downloaded to the CTRL module and memory capacities:

Data to be downloaded	Memory capacity
Application code	51,200 bytes
ISaGRAF variables and FB instances	25,600 bytes
ISaGRAF retained variables	4,096 bytes
Calculation Parameters, Calculation Monitor Parameters, and User-defined Parameters	51,200 bytes

■ Application code

● Contents

Application code is the data generated by compiling the application program created by the user on the ISaGRAF workbench.

The application code includes the attribute information on programs and variables. An application created by the user can be executed on this module by downloading the application code to the module.

● Memory capacity

51,200 bytes

● Memory usage calculation formula

There are no formulas to correctly calculate the memory usage of the application code. However, the memory usage of the application code created by the user can be checked using the following procedures.

- Refer to the size of the file "appli.x6m" generated by the ISaGRAF workbench after the project has been compiled. "appli.x6m" is generated in the directory of the working project. (Checking method before downloading)

-
- Read [Application Code Capacity] of the Memory Usage Monitor in the System Monitor Parameters of this module. (Checking method after downloading)

Note

To upload the data downloaded to this module, onto the personal computer, it is necessary to download [Zipped source code for upload] beforehand.

The zipped source is created using the [Compiler option] setup. (The initial value is "No Creation".)

Additionally, when creating the zipped source, the application code size becomes large (approximately 2 to 4 times larger than when not created). Care must be taken.

Handling Precautions

- The memory capacity is determined by taking the balance between the general application scale (4 control loop) and the operation speed into consideration. Even though this CTRL module is not applicable to a large-scale application, the application code footprint can be reduced by taking the following ideas:
 - Review the contents of the application program and omit meaningless processes and variables, when they exist.
 - Use optimize options when compiling.
 - Do not contain the zipped source for uploading.
 - Disperse the control loops by using more than one module.
- The zipped source for uploading is included in an application code. At this time, the size of the application code becomes about 2 - 4 times larger than that of the application without zipped source for uploading.
- When downloading the application code exceeding the memory capacity, the mode cannot be changed to Operating mode. The application code error alarm is generated in this module and the ISaGRAF debugger shows the error message, "Cannot allocate memory for application".

■ ISaGRAF variables and FB instances

● Contents

The variables and FB instances are data to be used on the application program. The information about how much the variables and FB instances are used is stored in the application code. This module allocates the memory according to this information.

● Memory capacity

25,600 bytes

● Memory usage calculation formula

The memory usage becomes almost equivalent to the total bytes of the following items:

- The number of Boolean variables $\times 1$
- The number of analog variables $\times 4$
- The number of timer variables $\times 4$
- The number of message variables \times (character string length of the declared message variable + 3)
- The number of programs $\times 1$
- The number of SFC steps $\times 28$
- The number of transitions $\times 16$
- Others (The number of I / O boards and FB instances used)

The total size of ISaGRAF variables and FB instances of the application program created by the user can be checked using [Realtime Database Usage] of the Memory Usage Monitor in the System Monitor Parameters of this module. (This is valid only after downloading.)

● List of FB instance sizes

The following shows the FB instance sizes used in the function blocks:

(Alphabetical order)

Function block name	FB instance size (bytes)
AVERAGE	524
BLINK	12
CMP	2
CTD	8
CTU	8
CTUD	8
DED	444
DERIVATE	24
F_TRIG	4
HYSTER	2
INTEGRAL	12
LERD_LAG	32
LIM_ALRM	2
MAV	168
PAR_BOOL	24
PAR_INT	32
PER_REAL	32
PAW_BOOL	44
PAW_INT	44
PAW_REAL	44

Function block name	FB instance size (bytes)
PID_A	168
PID_CAS	288
PLS_GEN	16
PSVC	20
PTN_EVR	84
PTN_MAIN	220
PTN_MODE	84
PTN_SUB	188
PTN_TEV	56
R_TRIG	4
Ra_PID	340
RAMP_GEN	56
RS	2
SIG_GEN	20
SR	2
TBL	20
TBR	20
TOF	12
TON	12
TP	12
UP_PID	148
ZONE7	8

! Handling Precautions

- The retained variables are also kept in this area. Furthermore, the memory backup area is also needed.
- When downloading the application code exceeding the memory capacity, the mode cannot be changed to Operating mode. The application code error alarm is generated in this module and the ISaGRAF debugger shows the error message, " Cannot allocate memory for run time data base".

■ ISaGRAF retained variables

● Contents

Those of the ISaGRAF variables having the retain attribute are particularly called "Retained variables". In addition to the area storing normal variables, the memory backup area is further needed. The information about how much the retained variables are used is stored in the application code. This module allocates the memory according to this information.

● Memory capacity

4,096 bytes

(Up to 1000 data can be declared as retained variables whose data type is integer or real.)

● Memory usage calculation formula

The memory usage of the retained variables is calculated from the following table:

Variable data type	Used memory size (byte)
BOOL type (Boolean type)	1 byte x number of used variables
DINT / REAL type (Integer / Real number type)	4 bytes x number of used variables
TIME type (Timer type)	5 bytes x number of used variables
STRING type (Message type)	256 bytes x number of used variables

The total size of ISaGRAF variables of the application program created by the user can be checked using [Retained Variables Usage] of the Memory Capacity Monitor in the System Monitor Parameters of this module. (This is valid only after downloading.)

! Handling Precautions

- If message type variables are declared as retained variables, only 16 variables (256 x 16 = 4096 bytes) can be retained at the maximum. Therefore, it is recommended not to use message type variables as retained variables.
- When downloading the application code exceeding the memory capacity, the mode cannot be changed to Operating mode. The application code error alarm is generated in this module and the ISaGRAF debugger shows the error message, "Cannot allocate memory for retained variables".

■ Calculation Parameters, Calculation Monitor Parameters, Program Pattern Parameters, and User-defined Parameters

● Contents

The Calculation Parameters, Calculation Monitor Parameters, Program Pattern Parameters, and User-defined Parameters are data, only necessary Parameters of which can be downloaded from the SLP-D50 to this module in order to use them.

The size, which can be downloaded, has two limitations, memory capacity and the number of allowable types and instances.

● Memory capacity

20,480 bytes

● Memory usage calculation formula

The memory usage becomes almost equivalent to the total bytes of the following items:

Parameter	Type	Memory usage calculation formula(bytes)
Calculation Parameter Calculation Monitor Parameter	For 1 instance	44 + (number of items in one group x number of group IDs per instance x 4)
Program Pattern Parameter	For 1 type definition	44 + (number of items in one group x 4)
User-defined Parameter	For 1 instance	44 + (number of items in one group x number of group IDs per instance x 4)

The total size can be checked using [Non-sys Params Usage] of the Memory Usage Monitor in the System Monitor Parameters of this module. (This is valid only after downloading.)

The above calculation must be totalized for all the number of used Parameter types and instances.

● Number of Calculation Parameter, Calculation Monitor Parameter, and Program Pattern Parameter items

When calculating the memory usage of Calculation Parameters, Calculation Monitor Parameters, and Program Pattern Parameters, the number of items in one group can be referenced in the following table:

Type label	Number of items in one group
PID_A Options	12
PID_A Constants	12
PID_CAS Options	25
PID_CAS Constants	15
Ra_PID Options	30
Ra_PID Constants	15
UP_PID Options	13
UP_PID Constants	11
TBL / TBR Options	40
PID_A Monitor	11
PID_CAS Monitor	25
Ra_PID Monitor	25
UP_PID Monitor	15
Pattern Setup	37
Segment Setup	12 to 52 (Note)
Pattern FB Monitor	58

Note : The number of items to be used is changed variably according to the number of events.

$$\text{Number of items} = 12 + (\text{Number of events} \times 2)$$

! Handling Precautions

The number of Calculation Parameter, Calculation Monitor Parameter, and Program Pattern Parameter items in one group may become larger than the number of item IDs stated in the Parameter table. This is caused by that the extension data, which the customer cannot see, is included. The values stated in the above table including the data for the extension needs to be used for the calculation.

● Number of allowable instances

200 instances

● Number of instances used calculation formula

The total of the calculated values in the following table becomes the number of used instances:

Parameter	Number of used instances calculation formula
Calculation Parameter Calculation Monitor Parameter	Total number of instances
Program Pattern Parameter User-defined Parameter	Total number of type IDs + Total number of instances

The total number can be checked using [Non-sys Params Tab Usage] of the Memory Usage Monitor in the System Monitor Parameters of this module. (This is valid only after downloading.)

Handling Precautions

- The instances described in this section include those of the following data:
 - Calculation Parameters
 - Calculation Monitor Parameters
 - Program Pattern Parameters
 - User-defined Parameters

These instances are different from the FB instances of the function block.

- When downloading the Calculation Parameters, Calculation Monitor Parameters, Program Pattern Parameters, and User-defined Parameters exceeding the memory capacity and / or the number of allowable instances, they can be accepted as long as the memory capacity allows downloading.
If such Parameters exceed the memory capacity, the download will be failed.

Communication module

Chapter 1. OVERVIEW

■ Features

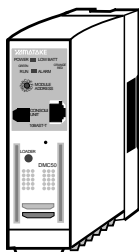

Accessible from network: This module is designed to enable the CPL communication (Controller Peripheral Link: Yamatake's host communication protocol) host and / or the loader to communicate with each CTRL module linked to this module through Ethernet (10BASE-T) or RS-485.

COM module is a module having the host communication capability. Two kinds of COM modules are provided: ME20X module (Ethernet type) and MR20X module (RS-485 type); Both of them are operated as a slave station. Up to eight CTRL modules are linked to one COM module. The data is exchanged with the CTRL modules via backplane communication, and the power is supplied to each module through the connected bases.

Note

This backplane communication is a communication method through the base connectors and / or extension cables.

■ Model selection guide

Basic model	Module type	Additional treatment	Special treatment	Description
DMC50				Module type controller
	ME20X			COM module, Ethernet type
	MR20X			COM module, RS-485 type
	XXXX0			Standard base type (connector connection type)
	XXXX1			Expansion base type (terminal connectable type)
		0 0		No additional treatment
		T 0		Tropicalization
		K 0		Anti-sulfide treatment
		D 0		Inspection Certificate provided
		B 0		Tropicalization and inspection certificate provided
		L 0		Anti-sulfide treatment and inspection certificate provided
		0 Y		Complying with the traceability certification
		T Y		Tropicalization and complying with the traceability certification
		K Y		Anti-sulfide treatment and complying with the traceability certification
		0 0 0 0	No special treatment	

■ Examples of system configurations

- The CTRL module is combined with the COM module.

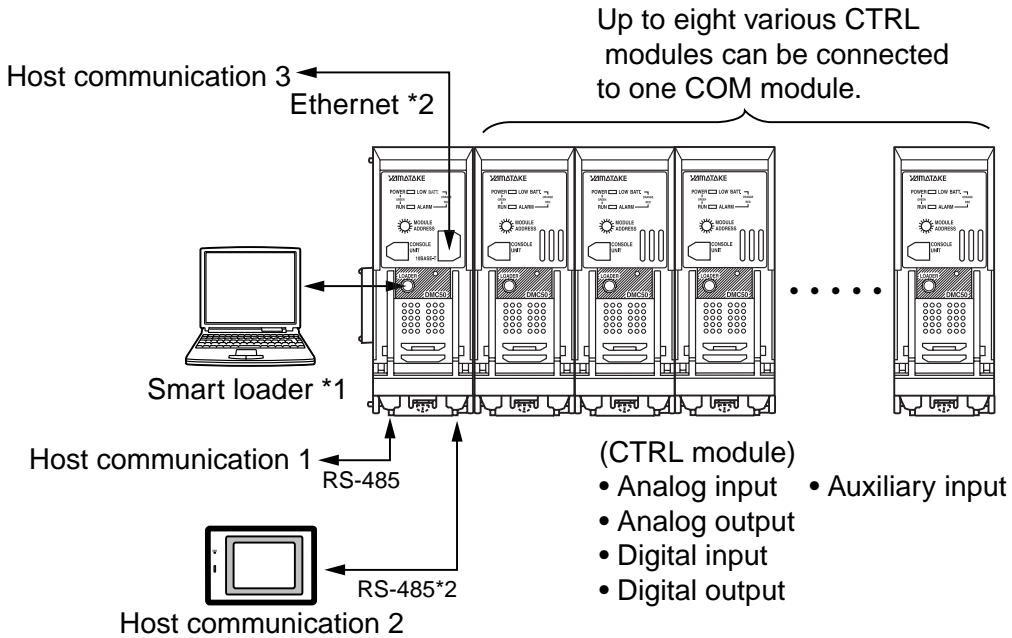

*1 For the smart loader, SLP-D50 specially designed for the DMC50 is available on the PC. The smart loader can also be connected through the host communication.

*2 ME200 module only

Chapter 2. NAMES AND FUNCTIONS OF PARTS

■ Body and base

● Standard base type

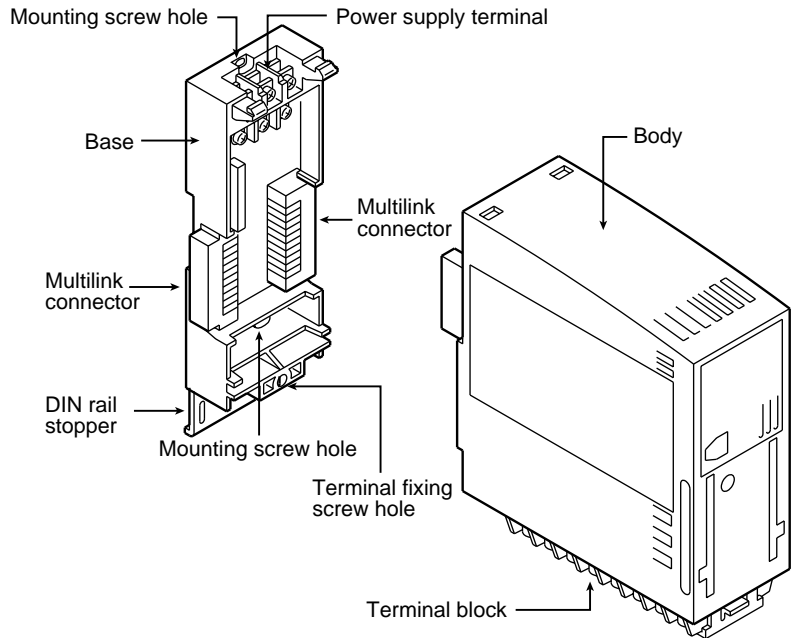

● Extension base type

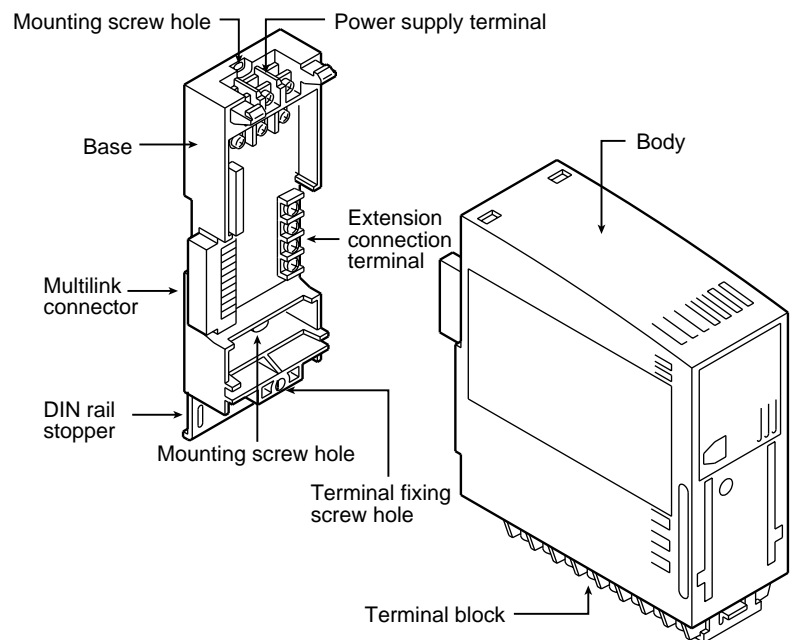

■ Terminal block

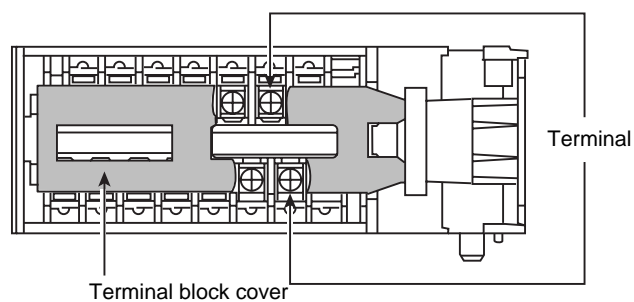

■ Front view

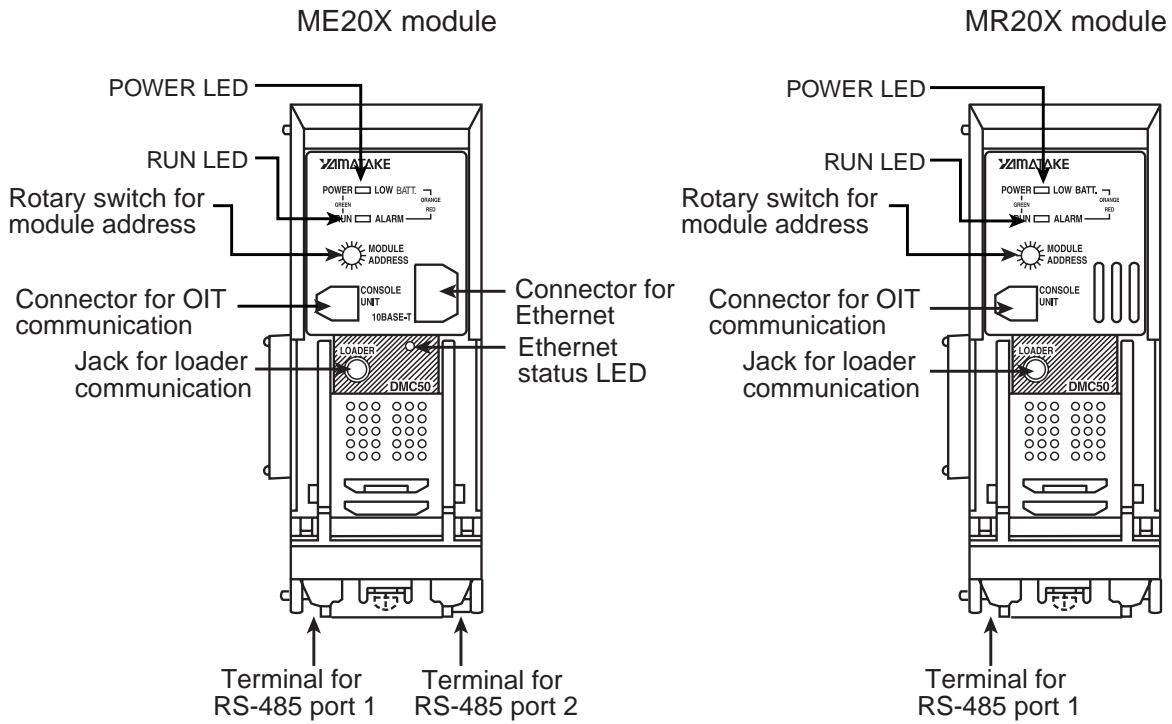

■ Input / output configuration of COM module

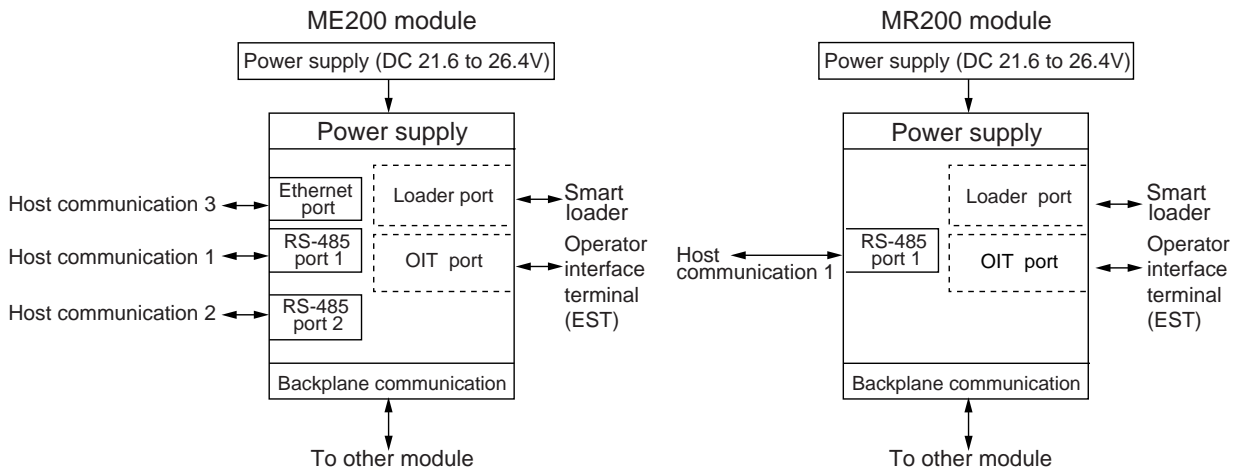

■ LED indications

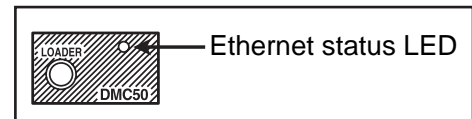
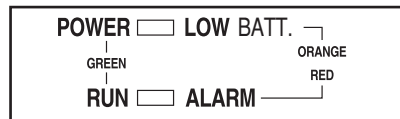

LED		Operation status
POWER	OFF	Power is not supplied.
	Lit in green	Power is supplied and the voltage of the built-in lithium battery is OK.
	Lit in orange	Power is supplied and the voltage of the built-in lithium battery drops.
	Flashing in orange	The rotary switch is set at "0". After the power has been turned ON, this LED flashes for approximately 5 sec., and then it is lit in green or orange.
RUN	OFF	No errors occur.
	Lit in red.	An error occurs.
Ethernet status (ME module only)	OFF	Ethernet is not linked.
	Lit in green.	Ethernet is being linked
	Lit in orange.	data is being exchanged through Ethernet.

■ Rotary switch



Relevant module address is set using this rotary switch. Set a module address ranging from 1 to F. It is also possible to set the same address as that set on a linked CTRL module.

! Handling Precautions

- Do not set the rotary switch to "0".
- Set the rotary switch properly. If the rotary switch is set to an incorrect position, such as that between two numbers, it is not possible to correctly communicate with the loader or other devices.

■ Communication types

Communication path	Port name / Communication H / W	Protocol	Connection method
Host communication 1	RS-485 port 1 / RS-485 compatible (5-wire)	CPL / Loader	Terminal connection
Host communication 2	RS-485 port 2 / RS-485 compatible (5-wire)	CPL / Loader	Terminal connection
Host communication 3	TCP / IP port 1 / Ethernet TCP / IP port 2 / Ethernet TCP / IP port 3 / Ethernet TCP / IP port 4 / Ethernet	Loader Loader CPL CPL	10BASE-T 10BASE-T 10BASE-T 10BASE-T
OIT(Operator Interface Terminal) communication	OIT port / RS-485 compatible(3-wire)	CPL	Modular jack
Loader communication	Loader port / CMOS	Loader	Loader jack

Chapter 3. INSTALLATION

WARNING



Do not touch any terminals or metal parts connected to the DMC50 when mounting or dismounting this module. Doing so might cause electric shock.



Do not disassemble the DMC50. Doing so might cause electric shock or faulty operation.

CAUTION



Use the DMC50 within the operating ranges recommended in the specifications (temperature, humidity, voltage, vibration, shock, mounting direction, atmosphere, etc.). Failure to do so might cause fire or faulty operation.



Do not block ventilation holes. Doing so might cause fire or faulty operation.



Wire the DMC50 properly according to predetermined standards. Also wire the DMC50 using designed power leads according to recognized installation methods. Failure to do so might cause electric shock, fire or faulty operation.

■ Installation place

Always install this module in a place where:

- High temperature, low temperature, high humidity, and low humidity do not exist.
- Corrosive gas, such as sulfured gas does not exist.
- Fine particle dust and oily smoke are minimized.
- Appropriate measures are taken so that it is neither exposed to direct sunlight, wind, nor rain.
- Mechanical vibration and impact are minimized.
- It is neither close to an electrical noise producing source, a place under the high-voltage cables, nor a welding machine.
- It is 15 m or more far away from a high-voltage ignition equipment, such as boiler.
- Effects of high magnetic field are minimized.
- Flammable fluid or steam does not exist.
- Heat produced by a heating element does not adversely affect.

■ Connecting modules

A module can be connected to other modules using the left and right multilink connectors on the base. Connect modules before mounting the modules on the DIN rail or the panel.

As modules are connected, the power supply of each module is connected. This might eliminate the power supply wiring.

■ Mounting

⚠ WARNING



Remove all protective seals from this module before putting this module into service.

Failure to do so may cause the faulty operation of this module itself or could result in fire due to this module overheating.

There are two mounting methods, panel mounting and DIN rail mounting. Select an appropriate method suitable for the equipment to be used.

The mounting posture allowed is only the mounting of this module on the vertical panel. It is not allowed to mount this module with its front display panel or terminal part faced upward.

Additionally, to prevent dust or metallic particles from entering this module through the ventilation holes until the operation is started, cover them with protective seals, when necessary.

To safely mount or unmount this module, a surrounding clearance shown in the following figure must be kept:

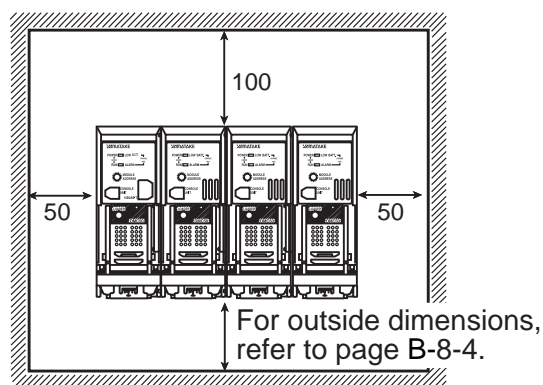

Unit: mm

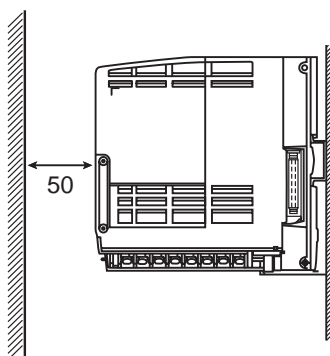

● Removing the body from the base

- (1) Remove the terminal block cover.
- (2) Loosen the terminal block fixing screw.

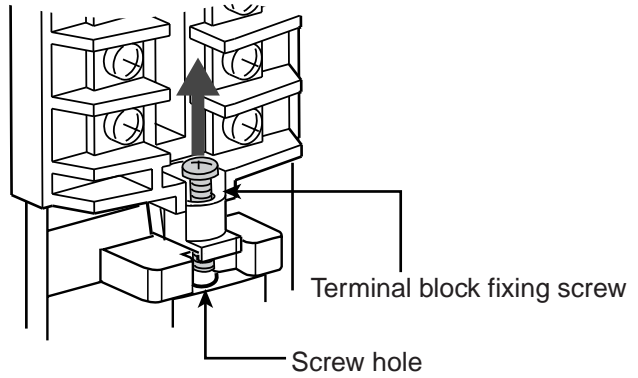
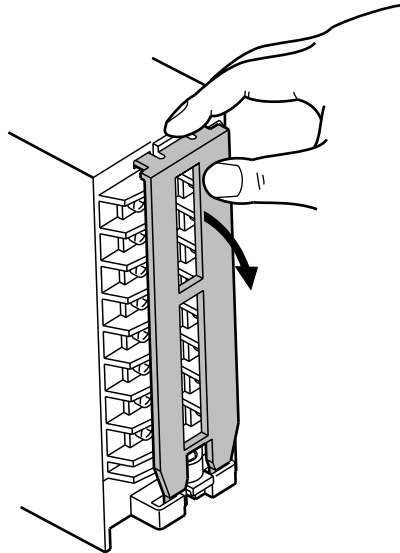

- (3) Raise the body in the direction indicated by an arrow to remove the body from the base.

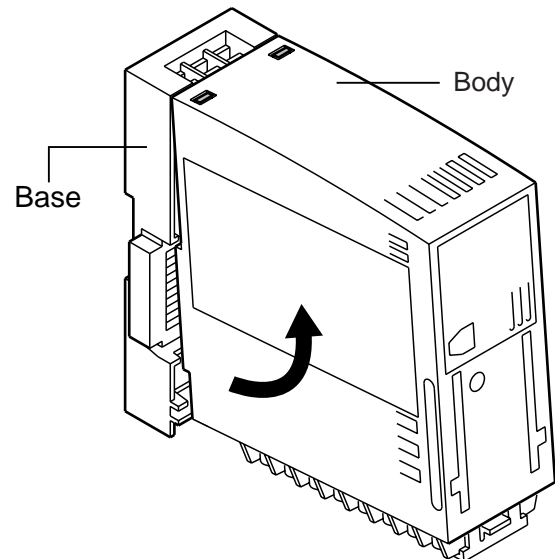

● panel mounting

Secure the base by tightening the M3 screws through the upper and lower base mounting holes. Here, the screw tightening torque is 1.8 N•m.

Unit : mm

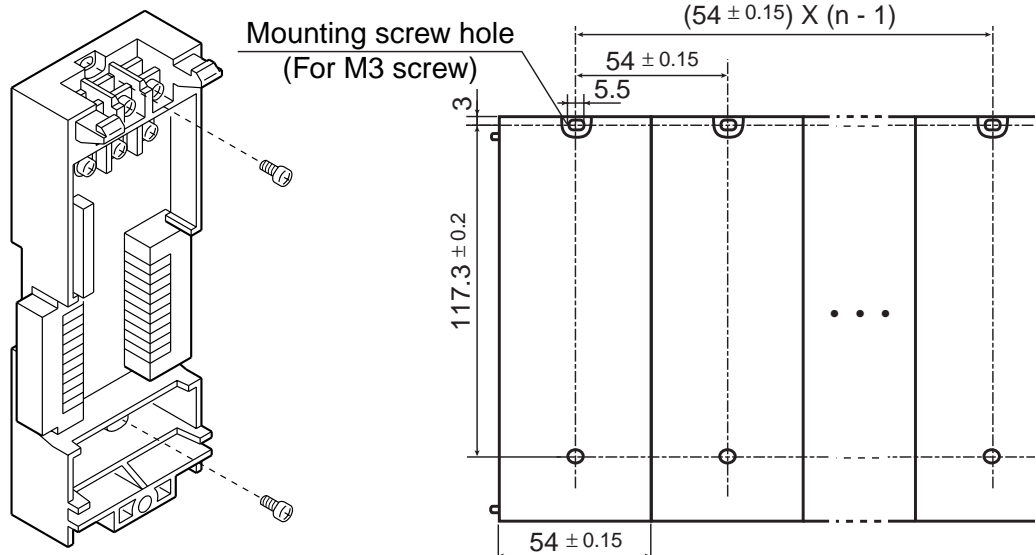

● **DIN rail mounting**

After the DIN rail has been secured, pull out the DIN rail stopper sufficiently until a click sounds, and then hang the base on the rail. Next, push up the DIN rail stopper to lock it. After that, mount the body.

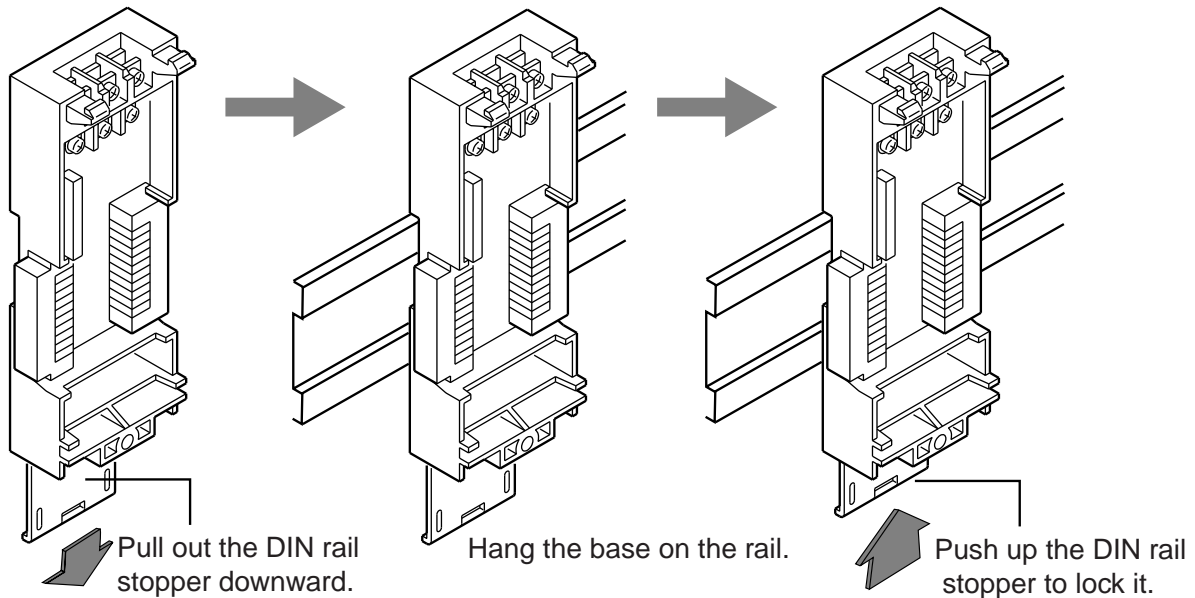

● **Mounting the body to the base**

Fit the hook holes onto the hooks and push the body toward the base until a click sounds.

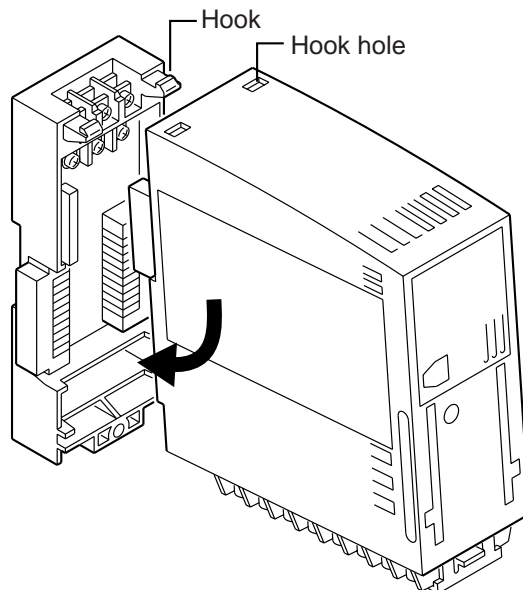

After the wiring to the terminal block has been completed, tighten the terminal block fixing screws firmly, and then attach the terminal block cover.

Chapter 4. WIRING

4 - 1 Wiring precautions

WARNING



Ground the FG terminal with a ground resistance of a maximum of 100 Ω before connecting this module to the measurement target or external control circuits.
Failure to do so might cause electric shock or fire.



Before removing / mounting or wiring the DMC50, be sure to turn the source power OFF.
Doing so might cause electric shock.



Do not touch electrically charged parts such as the power terminals.
Doing so might cause electric shock.

CAUTION



Wire the DMC50 properly according to predetermined standards.
Also wire the DMC50 using designed power leads according to recognized installation methods.
Failure to do so might cause electric shock, fire or faulty operation.



Do not allow lead clippings, chips or water to enter the DMC50 case.
Doing so might cause fire or faulty operation.



Firmly tighten the terminal screws and mounting screws at the torque listed in the specifications.
Insufficient tightening of terminal screws might cause electric shock or fire.



Do not use unused terminals on the DMC50 as relay terminals.
Doing so might cause electric shock, fire or faulty operation.





We recommend attaching the terminal cover after wiring the DMC50.
Failure to do so might cause electric shock.

Handling Precautions

- This module is not equipped with the power switch and protective fuse. When necessary, prepare such parts outside this module. For the controller power wiring, install a main power shutdown switch in an area where the operator can operate it easily.
- Before starting wiring, always check the controller models and terminal Nos. on the wiring diagram label attached to the side panel of the body.
- Keep the input signal lines and communication lines 50 cm or more away from power distribution lines, motor power cables and power supply lines having a voltage of 100V or more to eliminate adverse effects.
- Pay special attention so that no crimp terminals used for the terminal wiring are in contact with adjacent terminals.

■ Wiring diagram labels

The following shows the meanings of the symbols used in the wiring diagram labels attached to the side panels of this module:

-  Grounding terminal
-  Electric shock hazard
-  Warning/ Caution

● COM module (common to ME20X and MR20X modules)

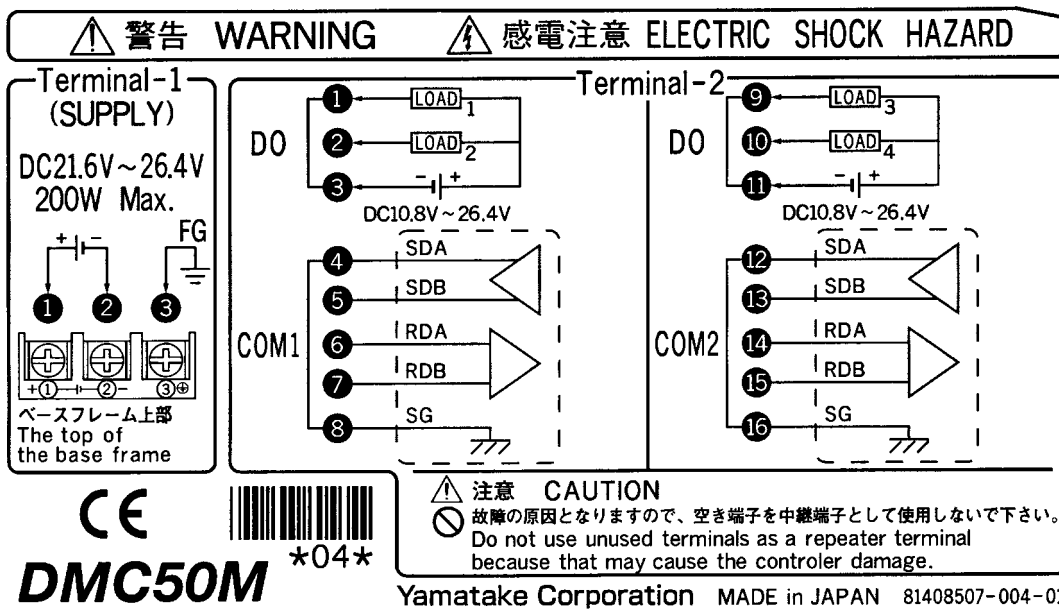

4 - 2 Connections

⚠ CAUTION

- ❗ Firmly tighten the terminal screws at the torque listed in the specifications. Insufficient tightening of terminal screws might cause electric shock or fire.
- ⊘ Do not use unused terminals on the DMC50 as relay terminals. Doing so might cause electric shock, fire or faulty operation.
- ❗ We recommend attaching the terminal cover after wiring the DMC50. Failure to do so might cause electric shock.

Always use an appropriate crimp terminal corresponding to the M3.5 screw.

Unit : mm

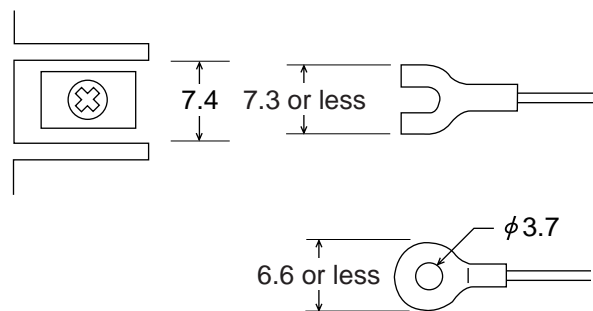

Terminal screw tightening torque is 0.78 to 0.98 N • m.

ⓘ Handling Precautions

- When installing this module in a place where the vibration or impact is large, always use appropriate crimp ring terminals so that wires do not come from the connection terminals.
- Pay special attention so that no crimp terminals are in contact with adjacent terminals.

■ Connecting the power supply

Connect the power supply terminals as shown in the following:

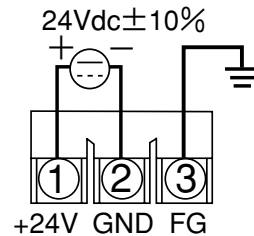

! Handling Precautions

- Connect an appropriate DC power supply with less switching noise to this module so that adverse effects of the noise are minimized. Failure to do so might cause the module to malfunction or the analog input to fluctuate.
- Always ground the FG terminal of the DC power supply properly. Failure to do so might cause the module to malfunction or the analog input to fluctuate.
- If the noise produced by the power supply is large, it is recommended to add an appropriate isolation transformer to the primary side of the DC power supply and to put a line filter for the DC power supply between this module and DC power supply.
- Do not bundle the power cable and grounding cable of this module together with power distribution lines or motor power cables, and do not put the power cable and grounding cable together with power distribution lines or motor power cables in the same wiring conduit or duct.
- Perform the wiring so that the length of the power cable is 30m or less.
- The power line is mutually connected between modules connected by multilink connectors. Therefore, connect the power supply to only one module. This will supply the electric power to all modules. Do not connect the power supply to multiple modules or do not connect multiple power supplies to one module. Doing so might cause a malfunction.
- The power line between the modules linked with the extension cable is not connected. Therefore, connect the power supply to each set of connected modules.

Examples of power supply connections

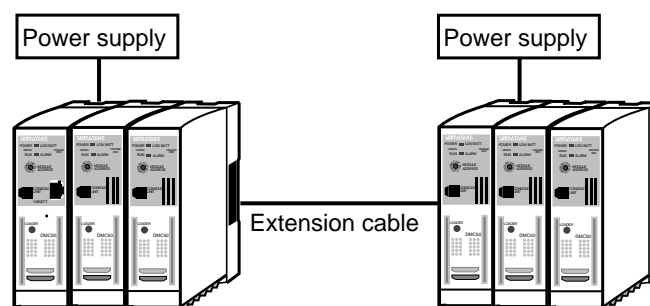

■ Grounding

Ground the FG terminal of this module properly.

Grounding resistance : 100Ω or less

Grounding cable : Annealed copper wire with a cross sectional area of 2 mm² (AWG14)

Length of grounding wire : 20m max.

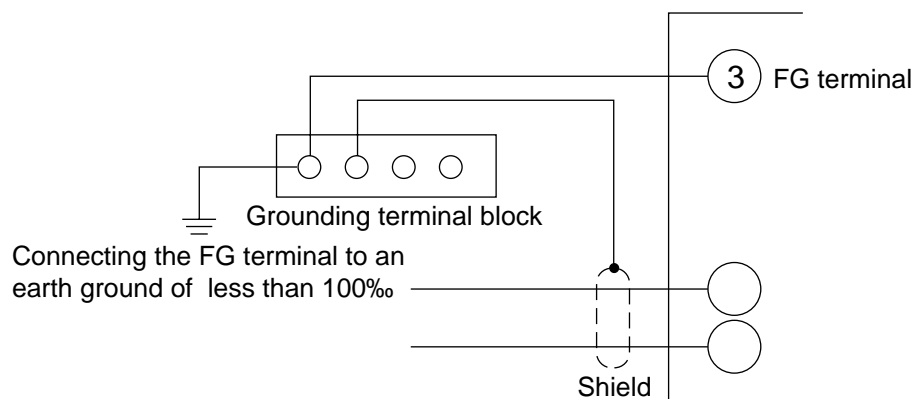

ⓘ Handling Precautions

- If it is difficult to ground the shielded cable, prepare a separate grounding terminal block (or earth bar).
- Do not connect the FG terminal of this module to the FG terminal of other instruments.
- The FG terminals are mutually connected between connected modules. Therefore, if only one module is grounded, all connected modules are grounded. Therefore, it is not necessary to connect the grounding cable to each module.
- The FG terminals between modules linked with the extension cable are not connected. Therefore, connect the grounding cable to each set of connected modules.

■ Connecting wires to the terminal block

To connect wires to input terminals, always use appropriate crimp terminals corresponding to the M3.5 screw.

! Handling Precautions

- When installing this module in a place where the vibration or impact is large, always use appropriate crimp ring terminals so that wires do not come loose from the connection terminals.
- Pay special attention so that no crimp terminals are in contact with adjacent terminals.

The terminal block is located at the lower portion of this module. However, the terminal block is designed to be movable to improve the wiring workability.

- (1) Put your finger on the terminal cover and pull the cover in the direction as shown in the Figure to remove it.
- (2) Loosen the terminal block fixing screw until it is removed from the screw hole.

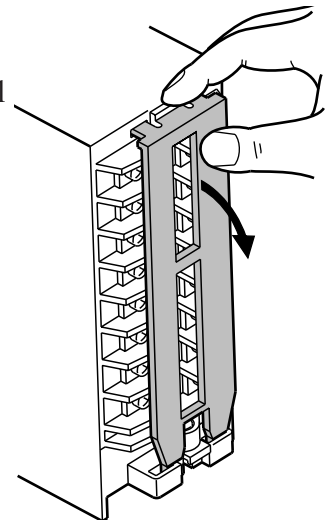

! Handling Precautions

Do not remove the terminal block fixing screw completely, but only loosen it.

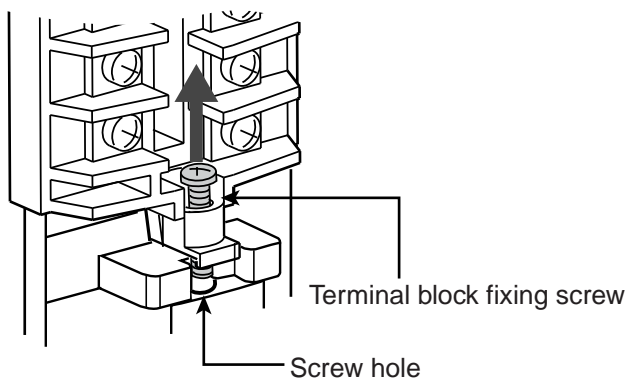

- (3) Pull the hook of the terminal block fixing screw part and pull out the terminal block in the direction indicated by an arrow.

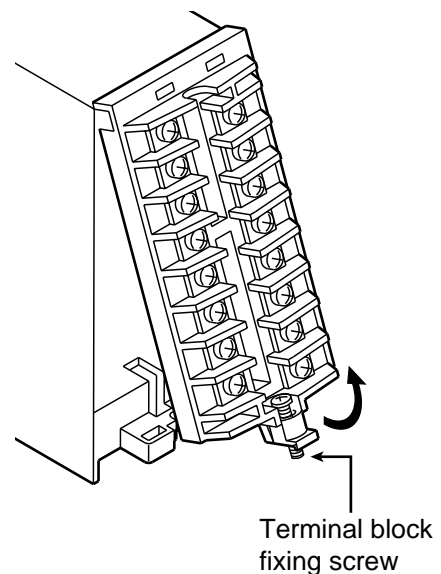

- (4) With the terminal block kept opened 90°, slide the terminal block in the slide grooves along with the front panel.

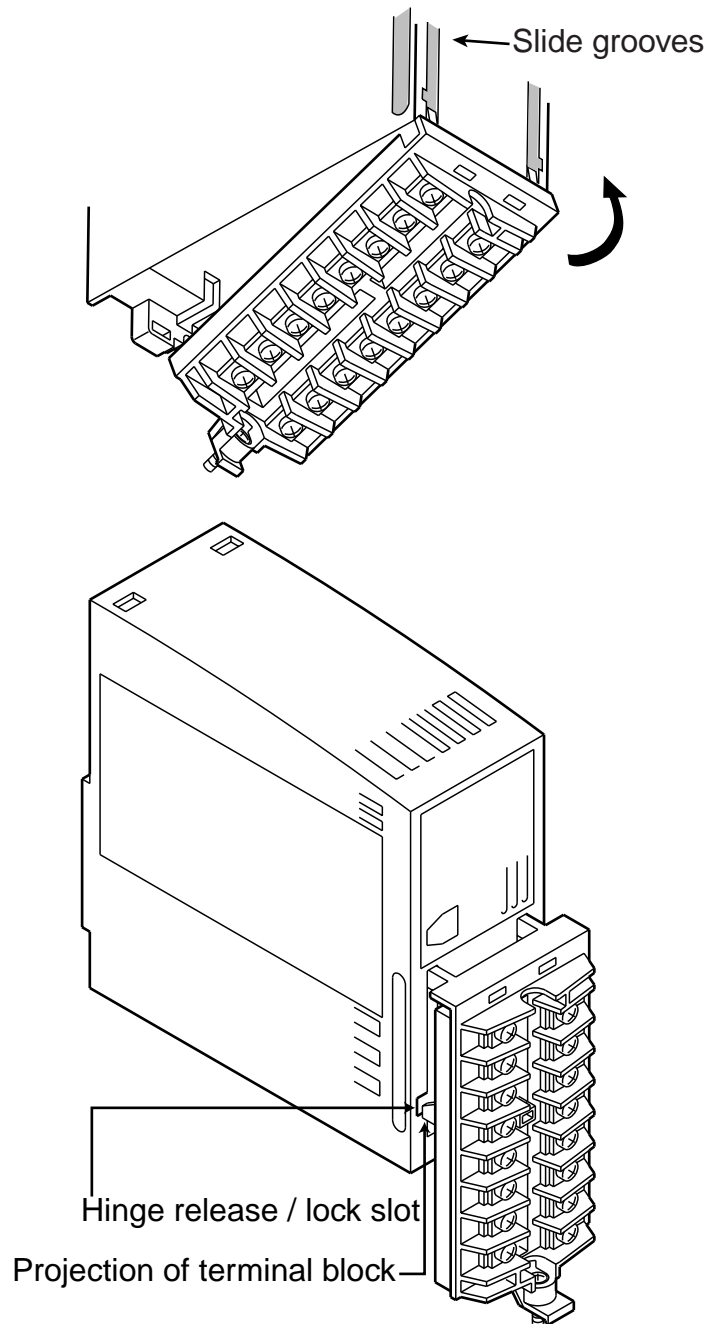

- (5) Connect the wires in this position.
(6) After the wires have been connected completely, return the terminal block to its original position in the reverse order of above steps and tighten the terminal block fixing screw.

■ Connecting the loader

This module uses smart loader package SLP-D50, which runs on a personal computer, as a loader. To connect to a personal computer, use the jack for the loader communication on the front display panel. To connect to a personal computer, use the loader cable (model 81440793-001).

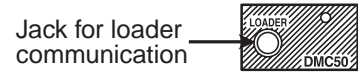

■ Linking Modules

Up to eight CTRL modules can be linked to one COM module. Once the power supply is connected to one module, the electric power is supplied to all the connected modules linked with multilink connectors. Furthermore, it is also possible to link the modules with the extension cable.

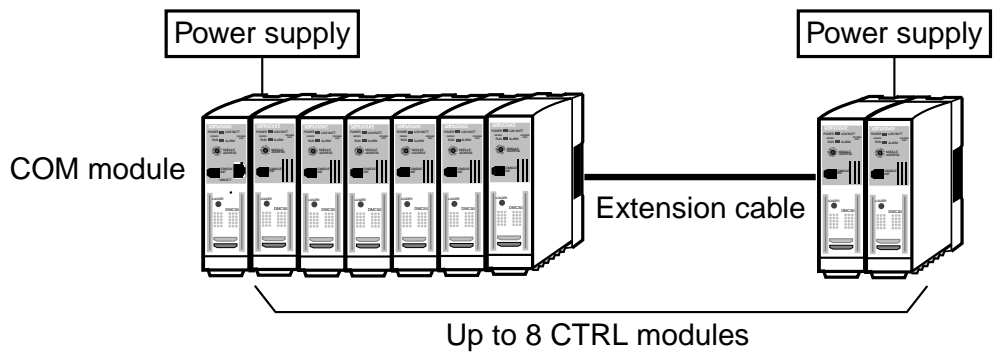

! Handling Precautions

- Insert the Multilink connector used for connecting the bases firmly.
- To link the modules with the extension cable, use an extension base. In this case, the power line is not connected. Therefore, separate power supply wiring is required.

■ Connecting with the extension base

Make the link with the extension base as shown in the Figure below.
To link the extension bases, use a shielded twist pair cable.

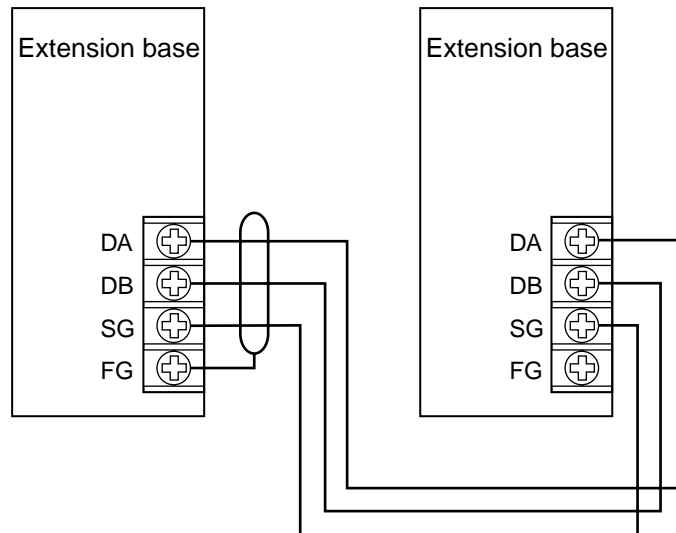

! Handling Precautions

- Perform the wiring so that the length of the extension cable is less than 20 m.
- Do not ground the FG terminals at both ends of the shielded extension cable. Ground only one FG terminal.

■ Operator Interface Terminal (OIT) communication

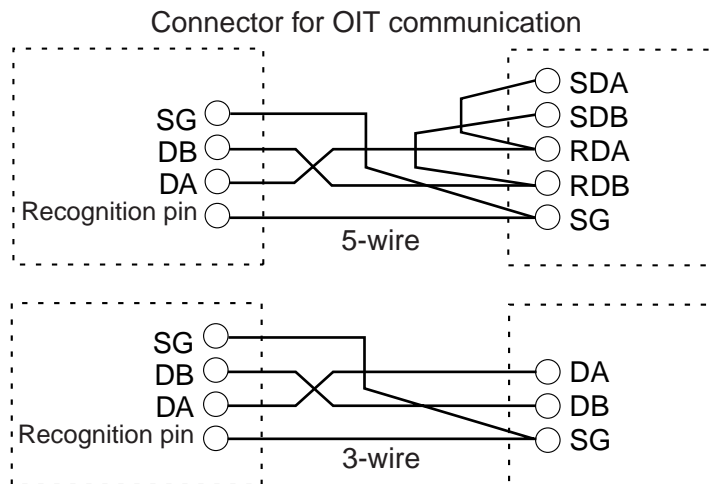
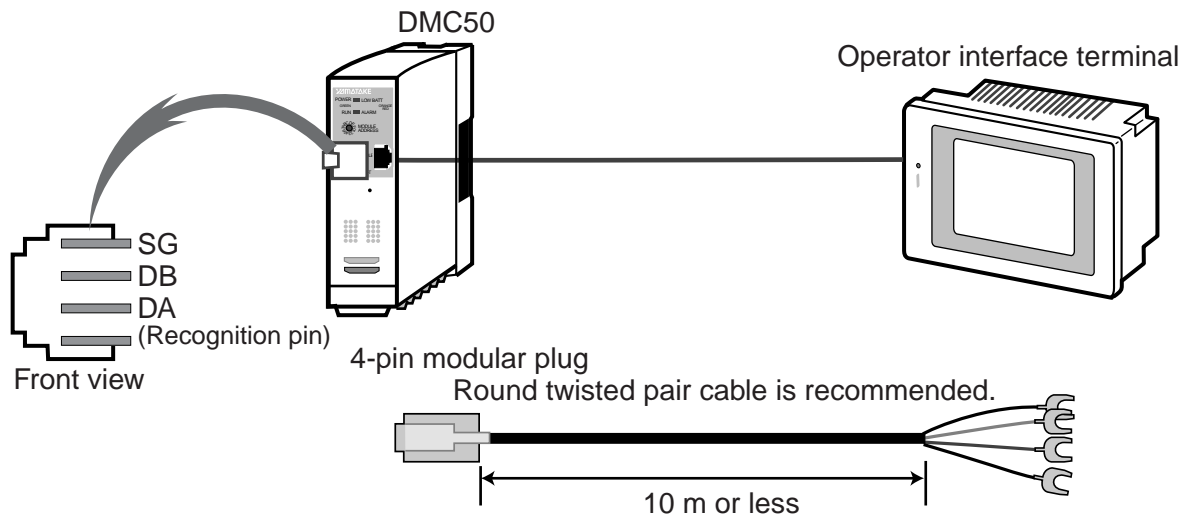

! Handling Precautions

- If the recognition pin is not connected to SG, the communication cannot be performed.
- When using the smart loader, plug out the modular plug.
- The OIT(Operator Interface Terminal) communication via the OIT port is not available in multi drop configurations.If connected in multi drop configuration, a communication error might occur.

■ Connecting wires for communications

The 5-wire or 3-wire RS-485 communication can be used. Short circuit between the SDA and RDA terminals, and between the SDB and RDB terminals when using the 3-wire RS-485 communication.

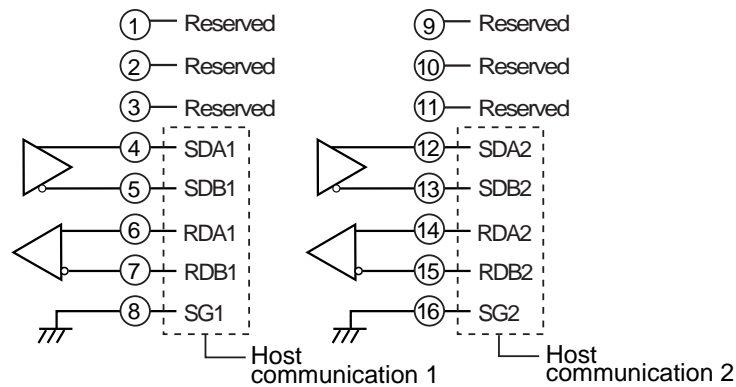

Terminal No.	Function	Terminal No.	Function
1	Reserved	9	Reserved
2	Reserved	10	Reserved
3	Reserved	11	Reserved
4	Host communication SDA1	12	Host communication SDA2
5	Host communication SDB1	13	Host communication SDB2
6	Host communication RDA1	14	Host communication RDA2
7	Host communication RDB1	15	Host communication RDB2
8	Host communication SG1	16	Host communication SG2

! Handling Precautions

- Do not short circuit between the SDA and SDB terminals or between the RDA and RDB terminals. Doing so might cause this module to break.
- Connect the terminating resistors (four resistors in total) to the physical ends of the communication path for the RS-485 communication (5-wire) and those (two resistors in total) to the physical ends of the communication path for the RS-485 communication (3-wire).
Use a resistor with a resistance of $150 \Omega \pm 5\%$ and a power consumption of $1 / 2W$ or more for the terminating resistor.
- Some devices connected to the host communication (RS-485 port) do not require terminating resistors. Always connect terminating resistors after checking the communication status.
- Set the COM module address so that it is not duplicated with the address already assigned to other connected device.
However, since the COM module functions as a master station in the communications with the CTRL modules, it is possible that the address assigned to the COM module is duplicated with the addresses assigned to the CTRL modules.
- Reserved terminals 1, 2, 3, 9, 10, and 11 are connected to the internal circuit. Therefore, do not use these terminals as relay terminals.

■ Connecting to 5-wire device

When connecting to a 5-wire device, make the wiring as shown in the Figure below.

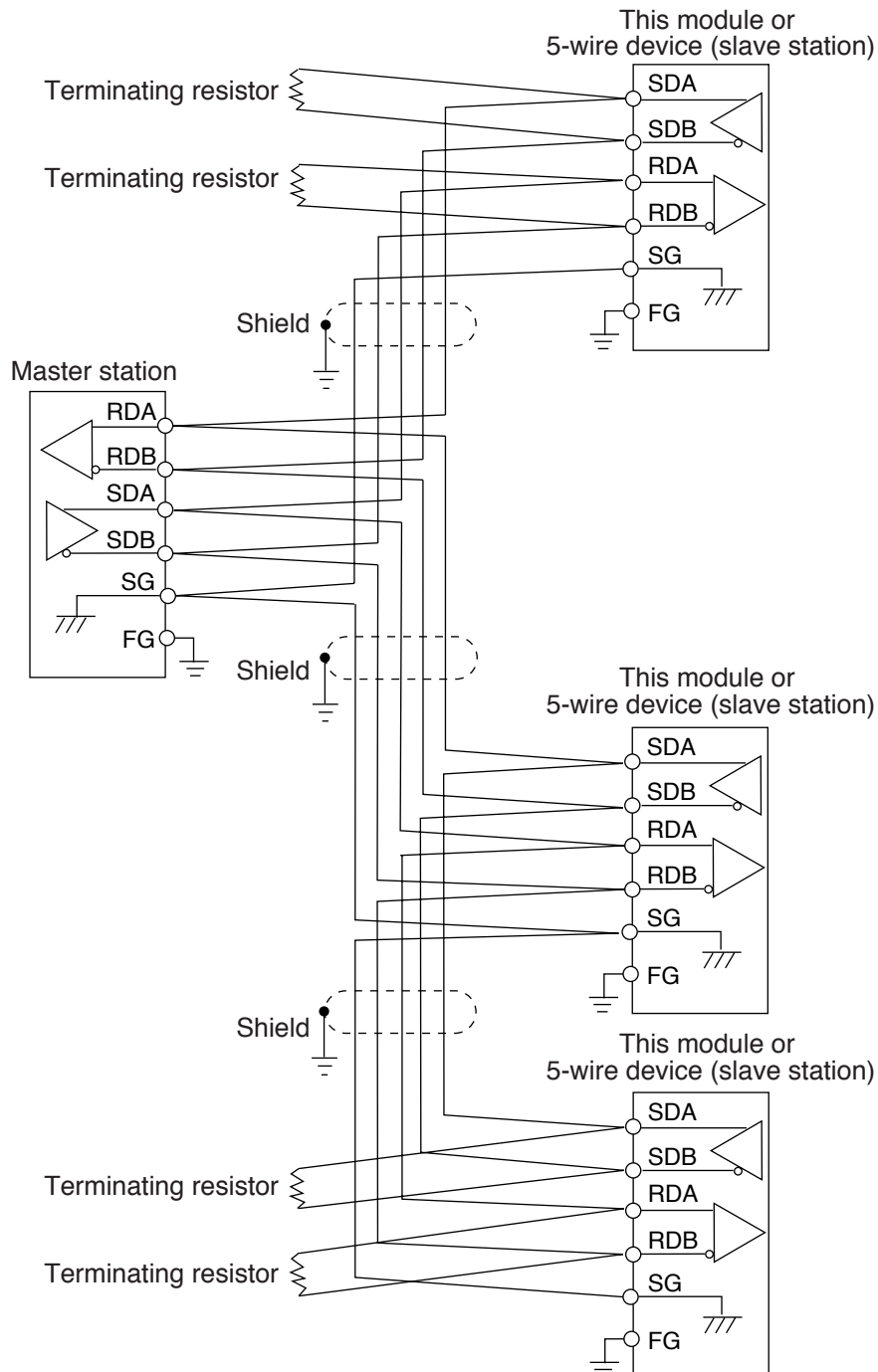

Connect a terminating resistor with a resistance of $150\Omega \pm 5\%$ and a power consumption of $1 / 2W$ or more to both ends of the communication path. Ground the shield to the FG at one end of the shield. Make sure that the shield is not grounded at both ends of the shield.

■ Connecting to 3-wire device

When connecting to a 3-wire device, make the wiring as shown in the Figure below.

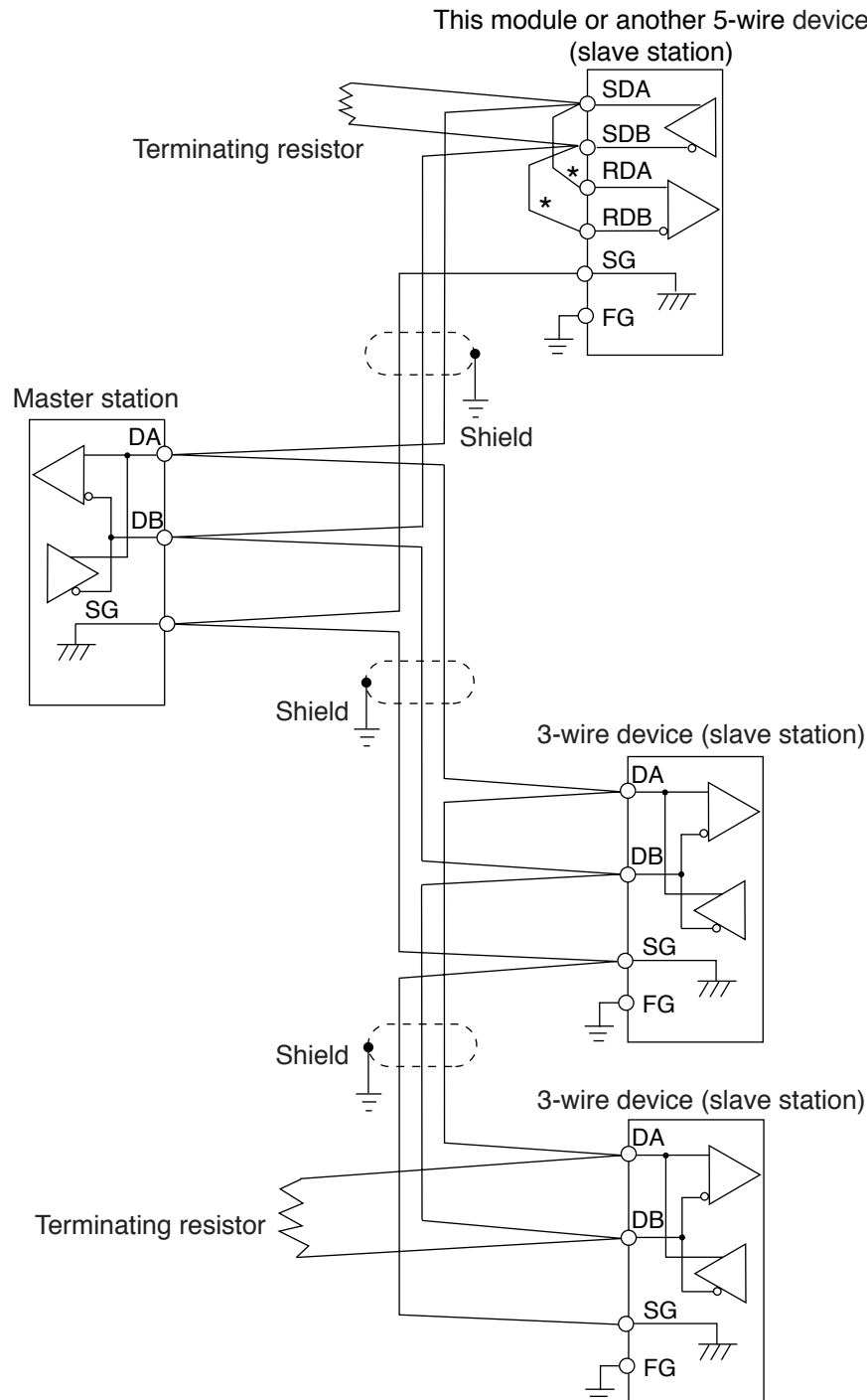

Connect a terminating resistor with a resistance of $150\Omega \pm 5\%$ and a power consumption of $1/2W$ or more to both ends of the communication path. Ground the shield to the FG at one end of the shield. Make sure that the shield is not grounded at both ends of the shield. Short circuit between the SDA and RDA terminals, and between the SDB and RDB terminals of each COM module.

■ Example of connection with EST240Z

To connect to the operator interface terminal, use an appropriate shielded twisted pair cable.

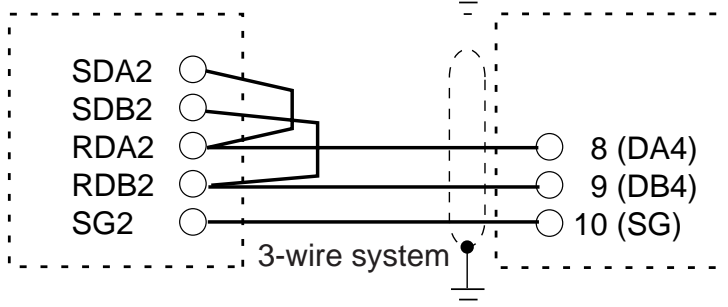
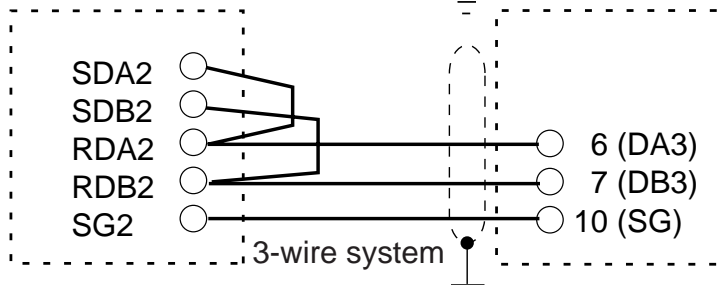
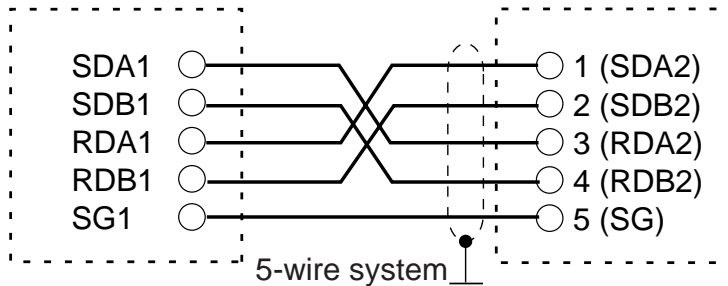
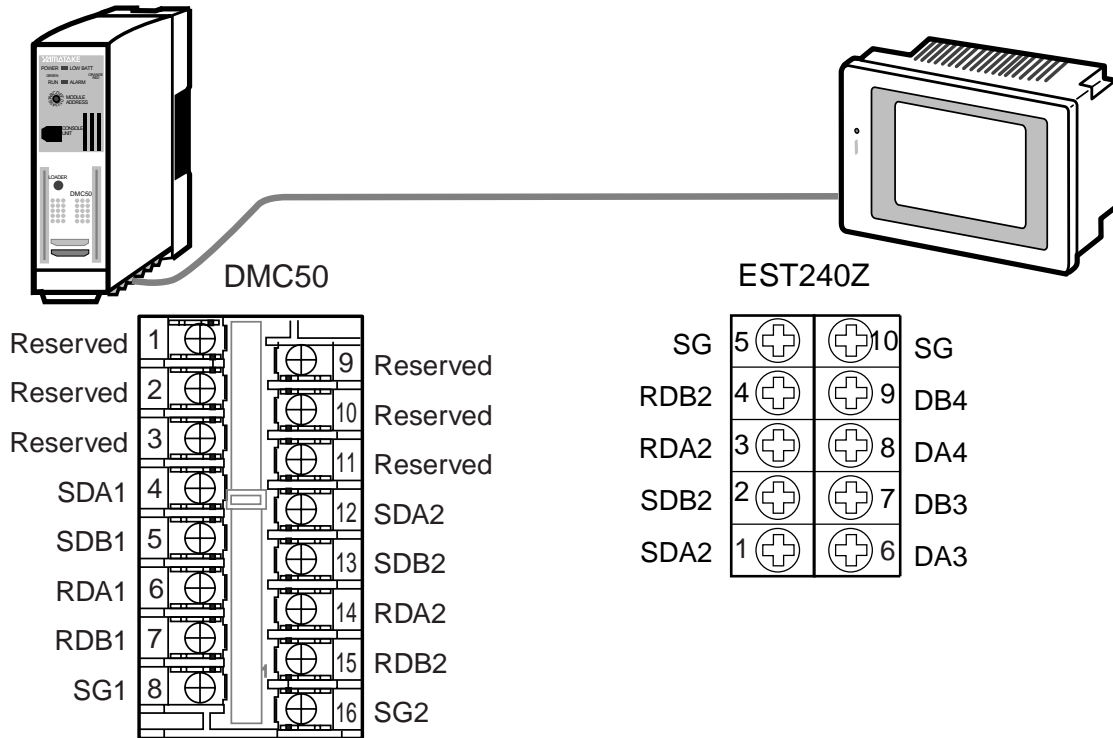

■ Recommended cables

Use a shielded twisted pair cable for the RS-485 cable.

For the Ethernet cable, use a category 3 / 4 / 5 shielded twisted pair cable for 10BASE-T.

! Handling Precautions

- It is also possible to use an unshielded twisted pair cable for the Ethernet. However, external noise may adversely affect the module.
- Connecting through 100BASE-TX / 10BASE-T auto-sensing or auto-negotiation switching hub, might cause trouble.
Do not use 100BASE-TX / 10BASE-T auto-sensing or auto-negotiation switching hub. Always use a repeater hub.
- Do not connect the devices with 10BASE-T cross-cable directly.
Doing so might cause incorrect recognition.

■ Isolation between input and output

The connections of this module are isolated as shown in the following:

Connection	Number of isolation blocks
Host communication 1 (RS-485 port 1)	1
Host communication 2 (RS-485 port 2)	1
Back-plane communication	1
Loader port / OIT port	1
Ethernet port	1

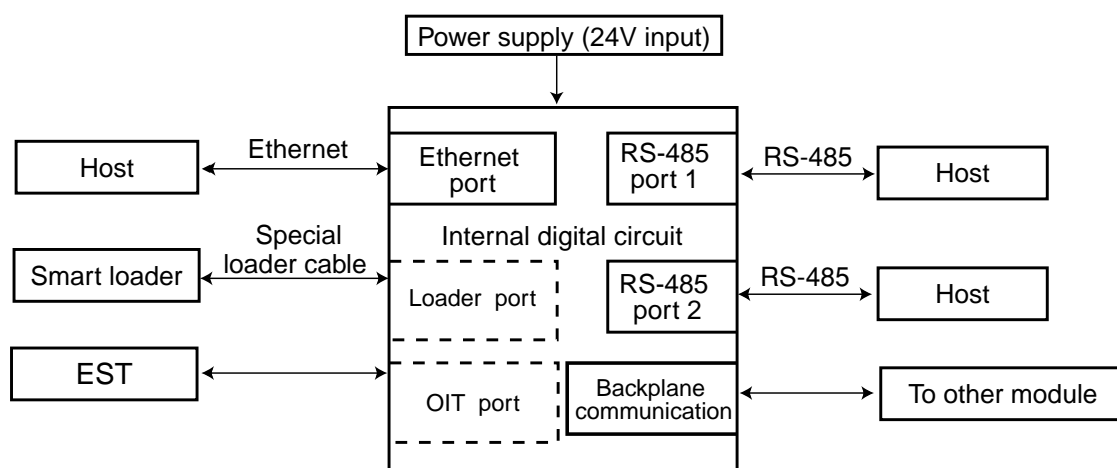

*Portions surrounded by solid lines are isolated from other blocks.

Chapter 5. PARAMETERS

5 - 1 Parameter lists

The following shows the Parameter lists of the COM module:

● System Parameters

Type label	Description
Date and Time Setup	The date and time of the built-in real-time clock of this module are set.
ME20X Communication Setup	This setup is only for the ME20X module. The settings related to the communication of the ME20X module are made.
MR20X Communication Setup	This setup is only for the MR20X module. The settings related to the communication of the MR20X module are made.
Front Port Communication Setup	The settings related to the front panel port are made. The transmission speed of the OIT(Operator Interface Terminal) port is changed.

● System Monitor Parameters

Type label	Description
System Alarm Log	Up to 16 latest system alarm generation / reset records can be checked.
H / W Info	The model and ROM revision of this module can be checked.
System Status	The alarm status of this module can be checked. The error status, such as memory error or battery voltage drop can be checked.
Date and Time Display	The date and time of the built-in real-time clock of this module can be checked.
ME20X Active Communication Setup	This is a Monitor Parameter only for the ME20X module. The communication settings actually being used on the ME20X module can be checked.
MR20X Active Communication Setup	This is a Monitor Parameter only for the MR20X module. The communication settings actually being used on the MR20X module can be checked.
Front Port Active Communication Setup	The communication settings actually being used for the front port can be checked.
MAC Address	This is a Monitor Parameter only for the ME20X module. The MAC address set on this module can be checked.

! Handling Precautions

Calculation Parameters, Calculation Monitor Parameters, Program Pattern Parameters, and User-defined Parameters are not provided on the COM module.

5 - 2 System Parameters

■ Date and Time Setup

The date and time of the built-in real time clock of this module are set.

Parameter type ID: 002h Group ID:001h

Item ID	Item name	Setting range	User level	Remarks	Data type
1	Year / Month / Day (BCD format)	00 01 01 to 99 12 31	0	This data is a value in the BCD format of "yymmdd". This value expresses like yy (year) -mm (month)-dd (day). "yy" shows the lower 2-digit value of the Christian year (1990 to 2089).	DWORD
2	Hour / Min / Sec	0 to 23 59 59 (BCD format)	0	This data is a value in the BCD format of "hhmmss". This value expresses hh (hour) -mm (minute)-ss (second). "hh" shows a value in the 24-hour format.	

● Item ID = 1 [Year / Month / Day]

The data of yymmdd expresses yy (year)-mm (month)-dd (day). "yy" shows the lower 2-digit value of the Christian year (1990 to 2089).

For example, to specify "January 1, 2000", enter "000101".

When [Year / Month / Day] is set, the day of the week is automatically set inside this module.

By reading this setting, it is also possible to check the currently set value.

● Item ID = 2 [Hour / Min / Sec]

The data of hhmmss expresses hh (hour)-mm (minute)-ss (second). "hh" shows a value in the 24-hour format.

For example, to specify "1:30:30 P.M.", enter "133030".

By reading this setting, it is also possible to check the currently set value.

■ ME20X Communication Setup

This setup is only for the ME20X module.

The communication settings of the ME20X module (RS-485 port 1, RS-485 port 2, and Ethernet) are made.

Parameter type ID: 0A1h Group ID: 001h

Item ID	Item name	Setting range	Factory setting	User level	Remarks	Data type
1	Trans. Speed (RS-485 port 1)	9600bps 19200bps 38400bps	9600bps	0		DINT
2	Protocol (RS-485 Port1)	0:None 1:CPL 2:Loader	1	0		
3	Trans. Speed (RS-485 port 2)	9600bps 19200bps 38400bps	9600bps	0		
4	Protocol (RS-485 Port2)	0:None 1:CPL 2:Loader	1	0		
5	IP Address	1.0.0.1 to 254.254.254.254	192.168.1.1	0		DWORD
6	Subnet Mask	0.0.0.0 to 255.255.255.255	255.255.255.0	0		
7	Default Router	0.0.0.0 to 254.254.254.254	0.0.0.0	0		
8	KeepAliveTime	60 to 32767s	7200	0		DINT
9	IP Port1	1024 to 65535	1250	0		
10	Protocol (IP Port1)	2:Loader	2	0	Fixed at setting 2 (loader). The setting cannot be changed.	
11	IP Port2	1024 to 65535	1251	0		
12	Protocol (IP Port2)	2:Loader	2	0	Fixed at setting 2 (loader). The setting cannot be changed.	
13	IP Port3	1024 to 65535	1252	0		
14	Protocol (IP Port3)	1:CPL	1	0	Fixed at setting 1 (CPL). The setting cannot be changed.	
15	IP Port 4	1024 to 65535	1253	0		
16	Protocol (IP Port4)	1:CPL	1	0	Fixed at setting 1 (CPL). The setting cannot be changed.	

For details about communication facilities,

☞ refer to Module Type Controller DMC50 User's Manual "Communications Connection" CP-SP-1093E.

[!] Handling Precautions

- Even though the setting is changed, this setting will not take effect immediately. The setting will take effect when the power is turned ON next time.
- The ME20X Communication Setup cannot be changed through the CPL communication. The setting must be changed from the SLP-D50.

● **Item ID = 2 [Protocol (RS-485 Port1)]**● **Item ID = 4 [Protocol (RS-485 Port2)]**

The protocol used for the RS-485 communication port can be changed.

When using the CPL communication, set this setting item to "setting 1 (CPL)".

When connecting to the SLP-D50, set this setting item to "setting 2 (Loader)".

● **Item ID = 5 [IP Address]**● **Item ID = 6 [Subnet Mask]**● **Item ID = 7 [Default Router]**● **Item ID = 8 [KeepAliveTime]**

These are the communication settings related to Ethernet.

The setting values vary depending on the network environment of the user. For details, consult the network administrator in charge of your network environment.

[!] Note

• IP Address

An IP address (currently, 4-byte length) is assigned to a device equipped with the IP protocol.

The IP address is set and changed by the user.

The user performs the communication using the IP address.

An appropriate IP address must be given by the system administrator of the place (department) where the module is actually used.

Ethernet allows construction of a large scale network through the bridge or modem. Therefore, there must be some kind of administration so that no IP addresses are duplicated.

• Subnet Mask

This setting subdivides one IP network address into multiple sub-IP networks. The upper bits representing the sub-IP network are "1" and all lower bits are "0".

• KeepAliveTime

This setting is a duration, at which the ME20X module checks the inactive TCP / IP connection which may be caused by power-down, reboot, or process-kill operation at the host / workstation without shutting-off of the connection to the ME20X module.

If the value is kept as the factory setting of 7,200 sec. (= 2 hrs.), the disconnection, caused by such operations as above, is not informed for 2 hrs, and the connection is kept active.

- Item ID = 9 [IP port 1],
- Item ID = 11 [IP port 2],
- Item ID = 13 [IP port 3],
- Item ID = 15 [IP port 4],
- Item ID = 10 [Protocol (IP port 1)]
- Item ID = 12 [Protocol (IP port 2)]
- Item ID = 14 [Protocol (IP port 3)]
- Item ID = 16 [Protocol (IP port 4)]

Four IP ports are provided on the ME20X module. The following shows factory settings of each IP port number and its protocol. Two ports can be used for the CPL communication. However, one port is used for backup if the timeout error occurs. Do not use two ports at the same time.

No.	Port No.	Protocol
IP port 1	1250	Loader communication server
IP port 2	1251	Loader communication server
IP port 3	1252	CPL communication server
IP port 4	1253	CPL communication server

Note

Port number

This number identifies the service type on TCP.

An IP address specifies a device or station, and a port number specifies a service type in the device or station.

Data to / from each port is handled separately.

IANA (Internet Assigned Numbers Authority) registers port numbers ranging from 1024 to 49151 as registered ports and opens the list of registered port numbers to public.

Factory setting port numbers 1250 to 1253 are registered ports, and you should check yourself the availability in your environment.

■ MR20X Communication Setup

This setup is only for the MR20X module.

The communication settings of the MR20X module (RS-485 port 1) are made.

Parameter type ID: 0A2h Group ID: 001h

Item ID	Item name	Setting range	Factory setting	User level	Remarks	Data type
1	Trans. speed (RS-485 port1)	9600bps 19200bps 38400bps	9600bps	0		DINT
2	Protocol (RS-485 port1)	0: None 1: CPL 2: Loader	1	0		

For details about communication facilities,

☞ refer to Module Type Controller DMC50 User's Manual "Communications Connection" CP-SP-1093E.

ⓘ Handling Precautions

- Even though the setting is changed, this setting will not take effect immediately. The setting will take effect when the power is turned ON next time.
- The MR20X Communication Setup cannot be changed through the CPL communication. The setting must be changed from the SLP-D50.

● Item ID = 2 [Protocol (RS-485 Port1)]

The protocol used for the RS-485 communication port can be changed.

When using the CPL communication, set this setting item to "setting 1 (CPL)".

When connecting to the SLP-D50, set this setting item to "setting 2 (Loader)".

■ Front Port Communication Setup

The settings related to the front port are made.

Parameter type ID: 0A3h Group ID: 001h

Item ID	Item name	Setting range	Factory setting	User level	Remarks	Data type
1	Trans. speed (OIT port)	9600bps 19200bps 38400bps	9600bps	0		DINT

The transmission speed of the OIT(Operator Interface Terminal) port can be changed.

For details about communication facilities,

☞ refer to Module Type Controller DMC50 User's Manual "Communications Connection" CP-SP-1093E.

 **Note**

- Two front ports are provided, "OIT port" and "Loader port".
- When connecting the loader port, the transmission speed is fixed at "9600 bps".

 **Handling Precautions**

- If the transmission speed is changed, this setting will take effect when the power is turned ON next time. Therefore, it is necessary to turn OFF the power, and turn it ON again if the transmission speed is changed.
- Note that the loader port and OIT port cannot be used at the same time.
If the jack for the loader communication and the modular connector for the OIT communication are connected at the same time, the communication cannot be performed correctly.
- The Front Port Communication Setup cannot be changed through the CPL communication. The setting must be changed from the SLP-D50.
- For the CTRL module, the setting cannot be changed in Operating mode. Always change the setting in Application inactive mode.

5 - 3 System Monitor Parameters

■ System Alarm Log

Up to 16 latest system alarm generation / reset records can be checked.

Parameter type ID: 0C4h Group ID: 001h

Item ID	Item name	Setting range	User level	Remarks	Data type
1	Latest Log Number	0 to 16	0	Latest log number "0" means that no logs exist.	DINT
2	Log 1 (Contents)	0 to FFFFFFFF	0	System alarm log (HEX format)	DWORD
3	Log 1 (Year / Month / Day)	00 01 01 to 99 12 31 (BCD format)	0	The year / month / day data of the system alarm generation / reset is a value in the BCD format of "yymmdd". This value expresses yy (year)-mm (month)-dd (day). "yy" shows the lower 2-digit value of the Christian year (1990 to 2089).	
4	Log 1 (Hour / Min / Sec)	0 to 23 59 59 (BCD format)	0	The hour / minute / second data of the system alarm generation / reset is a value in the BCD format of "hhmmss". This value expresses hh (hour)-mm (minute)-ss (second). "hh" shows a value in the 24-hour format.	
⋮	⋮	⋮	⋮	⋮	
47	Log 16 (Contents)		0		
48	Log 16 (Year / Month / Day)		0		
49	Log 16 (Hour / Min / Sec)		0		

For details about logging capability,

☞ refer to the appendix, Logging capability. (page B-App.-2).

● Item ID = 1 [Latest Log Number]

This shows the latest logged record number. When this value is 0, this shows that no logs exist.

Once the logging is performed, the value will be incremented only in a range from 1 to 16.

The next number of latest log number 16 is "1".

Additionally, when the value is set to "0", the log data will be cleared so that all the 16 records of [Log (Contents)], [Log (Year / Month / Day)], and [Log (Hour / Minute / Second)] data are cleared to "0".

● **Item ID = 2 to 49** [Log (Contents)], [Log (Year / Month / Day)], and [Log (Hour / Min / Sec)]

The logging results of the system alarms are shown. For details about system alarms,

☞ refer to the appendix, System status bit data, (page B-App-1).

■ **H / W Info**

The model and ROM revision of this module can be checked.

Parameter type ID: 001h Group ID: 001h

Item ID	Item name	Setting range	User level	Remarks	Data type
1	ROM ID	Not writable.	0		DINT
2	ROM ITEM		0		
3	ROM Revision		0		
4	Model ID		0	For model identification	
5	Module Type 1		0	For module type identification	
6	Module Type 2		0	Additional information by module type	
7	Num of AI Points		0		
8	Num of AUX-IN Points		0		
9	Num of AO Points		0		
10	Num of DI Points		0		
11	Num of DO Points		0		
12	Communication Option		0	Bit data (HEX format)	
13	Rotary Switch Position		0	For checking of module address. This shows the rotary switch position when the power is turned ON. Even though the rotary switch is changed while the power is being supplied, this setting does not reflect the change immediately.	

● **Item ID = 4** [Model ID]

Data	Description
1	MR20X (COM module: RS-485 type)
2	ME20X (COM module: Ethernet type)

● **Item ID = 5** [Module Type 1]

Data	Description
0	NG (Board configuration error)
1	COM module

● Item ID = 6 [Module Type2]

Data	Description
0	NG (Board configuration error)
1	Normal operation

● Item ID = 12 [Communication Option]

Model	Built-in communication ports				Data
	bit3	bit2	bit1	bit0	
	Ethernet port	RS-485 port 2	RS-485 port 1	OIT port Loader port	
MR20X	No	No	Yes	Yes	0003 h
ME20X	Yes	Yes	Yes	Yes	000F h

■ System Status

The alarm status of this module can be checked.

Parameter type ID: 0C1h Group ID: 001h

Item ID	Item name	Setting range	User level	Remarks	Data type
1	System Alarms	Not writable. (HEX format)	0	For COM module, the monitored values are always "0".	DWORD
2	AI Alarms		0		
3	AUX-IN Alarms		0		

The system status is expressed by the bit data.

For details,

☞ refer to the appendix, System status bit data, (page B-App.-1).

■ Date and Time Display

The date and time of the built-in real-time clock of this module are displayed.

Parameter type ID: 0C3h Group ID: 001h

Item ID	Item name	Setting range	User level	Remarks	Data type
1	Year	Not writable.	0	Christian year (1990 to 2089)	DINT
2	Month		0		
3	Day		0		
4	Day of Week		0	0: Sunday, 1: Monday, 2: Tuesday, 3: Wednesday, 4: Thursday, 5: Friday, 6: Saturday	DWORD
5	Hour		0	24-hour system	DINT
6	Min		0		
7	Sec		0		

■ ME20X Active Communication Setup

This is a monitor Parameter only for the ME20X module. The communication settings actually being used for each communication port (RS-485 port 1, RS-485 port 2, and Ethernet) of the ME20X module can be checked.

Parameter type ID: 0F1h Group ID: 001h

Item ID	Item name	Setting range	User level	Remarks	Data type
1	Trans. Speed (RS-485 port1)	Not writable.	0		DINT
2	Protocol (RS-485 port1)		0		
3	Trans. Speed (RS-485 port2)		0		
4	Protocol (RS-485 port 2)		0		
5	IP Address		0		DWORD
6	Subnet Mask		0		
7	Default Router		0		
8	KeepActiveTime		0		DINT
9	IP Port 1		0		
10	Protocol (IP port1)		0		
11	IP Port2		0		
12	Protocol (IP port2)		0		
13	IP Port 3		0		
14	Protocol (IP port3)		0		
15	IP Port4		0		
16	Protocol (IP port4)		0		

■ MR20X Active Communication Setup

This is a monitor Parameter only for the MR20X module.
The communication settings actually being used for each communication port (RS-485 port 1) of the MR20X module can be checked.

Parameter type ID: 0F2h Group ID: 001h

Item ID	Item name	Setting range	User level	Remarks	Data type
1	Trans. Speed (RS-485 port 1)	Not writable.	0		DINT
2	Protocol (RS-485 port 1)		0		

■ Front Port Active Communication Setup

The communication settings actually being used for the front port can be checked.

Parameter type ID: 0F3h Group ID: 001h

Item ID	Item name	Setting range	User level	Remarks	Data type
1	Trans. Speed (OIT port)	Not writable.	0		DINT
2	Trans. Speed (loader port)		0		

■ MAC Address

This is a Monitor Parameter only for the ME20X module.
The MAC address assigned to this module can be checked.

Note

- MAC address (Ethernet address)

This MAC address is 6-byte address assigned to all Ethernet devices.

The MAC address is a specific address assigned to each device and cannot be changed.

Additionally, there are no duplicated MAC addresses throughout the world.

A specific MAC address has been assigned to each ME20X module at shipment from the factory.

Since the client program uses the IP address, it can perform the communication without consideration of the MAC address.

Parameter type ID: 1E8h Group ID: 001h

Item ID	Item name	Setting range	User level	Remarks	Data type
1	MAC Address (Upper 4 nibbles)	Not writable.	0		DWORD
2	MAC Address (Upper 8 nibbles)		0		

Chapter 6. DATA ADDRESSES

6 - 1 Data address structure

Data address to be used for the CPL communication is a 32-bit address and expressed in the hexadecimal notation.

The data address space consists of only one area, "Parameter Address (PA)". The COM module does not include "Network address (NA)", which is available on the CTRL module.

■ About PA

Data specified by the address is "Parameter" specially designed for DMC50.

The following table shows the data address space:

Data address area	Data class	Address classifications
00010000 to FFFFFFFFh	Parameter	Parameter Addresses (PA)

Note

- The following kinds of Parameters are provided.
 - System Parameters
 - System Monitor Parameters
- The COM module does not include "Network address (NA)", which is available on the CTRL module.

■ Parameter Address (PA) structure

Parameter Address (PA) has the following structure:

* * * * * * * * h
 (1) (2) (3)

(1) Parameter type ID

The Parameter type ID represents a specific No. to identify such as AI Setup and PID_A Options. This ID consists of 12 bits and is expressed in hexadecimal notation in the data address list.

(2) Group ID

The group ID represents a channel No. , PID group No. or etc. This ID consists of 12 bits and is expressed in hexadecimal notation in the data address list.

(3) Item ID

The item ID represents an item No. This ID consists of 8 bits and is expressed in hexadecimal notation in the data address list.

● Example of data address

The PA of the System Alarms (item ID = 1) in the System Status (Parameter type ID = 0C1h) becomes "0C100101h".

6 - 2 Data address list (PA area)

The following table shows the data address list.

- Parameters are listed in order of address.
- The Parameter type ID and group ID are expressed in hexadecimal notation.
- For details about item IDs, refer to each Parameter list.
- The "Read / Write" column shows the accessibility for the CPL communication. The following shows the meanings of the "Read / Write" column:
 ✓ : Allowed.
 Blank: Not Allowed.

● System Parameters / System Monitor Parameters

Data address area	Parameter type ID	Group ID	Type label	Read	Write	Remarks
00100101 to 0010010D	001h	001h	H / W Info	✓		
00200101 to 00200102	002h	001h	Date and Time Setup	✓	✓	
0A100101 to 0A100110	0A1h	001h	ME20X Communication Setup	✓		
0A200101 to 0A200102	0A2h	001h	MR20X Communication Setup	✓		
0A300101 to 0A300101	0A3h	001h	Front Port Communication Setup	✓		
0C100101 to 0C100103	0C1h	001h	System Satus	✓		
0C300101 to 0C300107	0C3h	001h	Date and time display	✓		
0C400101 to 0C400131	0C4h	001h	System Alarm Log	✓	✓	
0F100101 to 0F100110	0F1h	001h	ME20X Active Communication Setup	✓		
0F200101 to 0F200102	0F2h	001h	MR20X Active Communication Setup	✓		
0F300101 to 0F300101	0F3h	001h	Front Port Active Communication Setup	✓		

! Handling Precautions

- The Communication Setups(ME20X /, MR20X /, Front Port) cannot be changed through the CPL communication. These settings are changed from the SLP-D50.
- The Calculation Parameters, Calculation Monitor Parameters, Program Pattern Parameters, and User-defined Parameters are not provided on the COM module.

Chapter 7. MAINTENANCE AND TROUBLESHOOTING

■ Maintenance

● Cleaning

To remove the dirt and dust from the controller, clean it with a dry soft cloth rag.

● Part replacement

Only expert engineers are allowed to carry out the parts replacement work.

■ Troubleshooting

● System alarms related

Indication / Symptom	Possible Cause	When detected
The RUN LED flashes in red at intervals of 1 sec.	ROM error	Every time the power is turned ON.
The RUN LED is lit in red and the calibration data error alarm is generated.	Calibration data error	Every time the power is turned ON.
The RUN LED is lit in red and the board configuration error alarm is generated.	Board configuration error	Every time the power is turned ON.
The RUN LED is lit in red and the System Parameter error alarm is generated.	Parameter error	During operation
The POWER LED is lit in orange, the RUN LED is lit in red, and the battery voltage drop alarm is generated.	Battery voltage drop	During operation
The CPL communication cannot be performed through RS-485.	CPL communication error (Wrong RS-485wiring)	During operation
When a client connected to the COM module through TCP / IP is abruptly aborted due to error, this connection remains for a long period of time.	(Keep Alive Time setting)	During operation

Description	Corrective actions
It has been detected that an error has occurred in the system program stored in ROM. Since the operation of this module cannot be started, the loader communication cannot also be operated.	Contact Yamatake Corporation.
It has been detected that an error has occurred in the calibration data copied from the non-volatile memory to RAM. In the COM module, the MAC Address is stored as calibration data.	Contact Yamatake Corporation.
Hardware (printed circuit board) combination not matching any valid module model has been detected.	Contact Yamatake Corporation.
It has been detected that an error has occurred in the Parameters stored in the backup RAM.	Download the application again. If the same error occurs after the application has been downloaded again, contact Yamatake Corporation.
Voltage drop of the battery for backing up data in RAM has been detected.	DO NOT replace the battery yourself. Contact Yamatake Corporation.
3-wire connection has been performed for a device not supporting 3-wire RS-485 connection. (Host communication 1 and 2)	Make the wiring by means of the supported connection method while referring to the instruction manual for the connected device.
The COM module does not check inactive TCP / IP connection unless an idle time of 2 hrs. (factory setting) elapses. The host / workstation connected to the COM module through TCP / IP has been powered OFF or reset without explicit disconnection from the server.	To release the inactive connection earlier than factory setting of 2 hrs., it is necessary to change the settings. Select [System Parameters] → [ME20X Communication Setup] → [Instance] → [KeepAliveTime] to change the setting (unit: sec). If KeepAliveTime setting is changed, this may affect other devices.

● Loader communication related

Indication / Symptom	Possible Cause	When detected
SLP-D50 shows the error message, "Timeout", and the loader communication cannot be performed.	Power supply is faulty.	
	Loader cable connection is faulty.	
	Rotary switch setting is faulty.	During operation
	The module address setting on SLP-D50 is faulty.	During operation
	The communication path setting on SLP-D50 is faulty.	During operation
	The connector for the OIT communication is connected at the same time.	
SLP-D50 cannot be connected through the COM module.	Rotary switch settings are duplicated.	During operation

Description	Corrective actions
Power is not supplied to this module.	Check that the POWER LED is lit in green.If the POWER LED is not lit in green, this shows that the power is not supplied.Supply the power to this module correctly.
The dedicated loader cable for connecting this module and personal computer is not connected correctly.	Connect the loader cable correctly. module address setting, and then turn ON the power again.
The rotary switch (module address setting) is set at "0" or at an intermediate position between numbers.	Set the rotary switch to a position other than "0" meeting the
The module address setting of the project (this is set by selecting [Project Options] from the [Options] menu in SLP-D50) does not match the rotary switch setting on this module (Module Address setting).	Adjust the module address setting in SLP-D50 to the rotary switch setting.
The communication path setting in SLP-D50 (this is set using the [Project Options] of the [Options] menu) does not meet the actual communication path.	Adjust the communication path setting in SLP-D50 to the communication path to be connected actually.
The loader communication cannot be performed when the modular plug is plugged in the modular jack for the OIT(Operator Interface Terminal) communication.	Disconnect the modular plug.
Rotary switch settings (module address setting) on multiple CTRL modules linked to one COM module are duplicated.	Make the settings so that the rotary switch settings on the CTRL modules are not duplicated, and then turn ON the power again.

Chapter 8. SPECIFICATIONS

■ General specifications

Item		Specifications	
Power supply	Power supply voltage	24Vdc \pm 10%	
	Power ON inrush current	30 A / 50 μ s or less per module	
	Start-up time	10s or less	
	Insulation resistance	20 M Ω or more between the power supply (24V) and isolated input / output and between the isolated input and output	
	Dielectric strength	DC 500V for 1 min. between the power supply (24V) and isolated input / output and between the isolated input and output	
	Current consumption	0.2 A or less	
	Power consumption	6 W or less	
	Battery life	10 years or longer under no power supply and standard conditions	
	Isolation	ME20X (Ethernet)	MR20X (RS-485 compatible)
	For internal circuit, loader communication, and OIT communication	For internal circuit, loader communication, and OIT communication	
	1 block	1 block	
	For backplane communication	For backplane communication	
	1 block	1 block	
	For host communication 1	For host communication 1	
	1 block	1 block	
	For host communication 2		
	1 block		
	For Ethernet		
	1 block		
	Total 5 isolation blocks	Total 3 isolation blocks	
Standard conditions	Ambient temperature	23°C \pm 2°C	
	Ambient humidity	60% \pm 5%RH (No condensation allowed)	
	Power supply voltage	24Vdc \pm 2%	
	Vibration resistance	0 m / s ²	
	Shock resistance	0 m / s ²	
	Mounting angle	Reference plane \pm 3°	
	Warm-up time	2 hrs. or longer	
	Ambient ventilation condition	To be installed in a place where wind is minimized.	
Operating conditions	Ambient temperature	0°C to 50°C	
	Ambient temperature for guaranteed accuracy	0°C to 50°C	
	Ambient humidity	20% to 90%RH (No condensation allowed.)	
	Vibration resistance	0.00 to 1.96 m / s ² (Panel mounting)	
	Shock resistance	0.00 to 9.80 m / s ² (Panel mounting)	
	Mounting angle	Reference plane \pm 10°	
	Approvals	EN61326-1-1997, AI-1998	

Item		Specifications
Transport / Storage conditions	Ambient temperature	-20°C to +70°C
	Ambient humidity	10% to 95%RH (No condensation allowed.)
	Vibration resistance	0 to 4.90 m / s ² (10 to 60 Hz for 2 hrs. each in X, Y, and Z directions)
	Shock resistance	0 to 490 m / s ² (3 times each for up and down)
	Package drop test	Drop height: 60 cm (1 angle, 3 edges, and 6 planes; free fall)
Other conditions	Maximum number of linkable modules	Up to eight CTRL modules are linked to one COM module
	Mounting	Panel mounting or DIN rail mounting M3 screw (Tightening torque: 1.8 N · m)
	Terminal screw	M3.5 screw (Tightening torque: 0.78 to 0.98 N·m)
	Case material	Modified PPE, Glass 10%
	Terminal cover material	PC (Polycarbonate) resin
	Mass	600 g or less

■ Communication specifications

Item		Specifications
Backplane communication	Transmission line type	RS-485 compatible, 3-wire, bus type
	Mode	Half-duplex
	Synchronization method	Asynchronous communication
	Maximum cable length	20m max. (with special loader cable)
	Terminating resistor	Not required.
	Connector	Special connector
Loader communication	Transmission line type	Special communication, one-to-one
	Mode	Half-duplex
	Synchronization method	Asynchronous communication
	Maximum cable length	2m max.(special cable needs to be used.)
	Transmission speed	9600 bps
	Connector	Stereo mini-pin jack (for special loader cable)

Item		Specifications
OIT communication	Operator Interface Terminal	EST-Z-series
	Transmission line type	RS-485 compatible, 3-wire, one-to-one
	Mode	Half-duplex
	Synchronization method	Asynchronous communication
	Maximum cable length	10m max.
	Terminating resistor	Not required.
	Transmission speed	9600 bps, 19200 bps, 38400 bps
	Bit length	8 bits
	Stop bit length	1 stop bit
	Parity bit	Even parity
	Connector	Special connector cable (One end is modular plug RJ-11: 4-pole and 4-core. ← → and the other end is terminals)
Host communication 1, 2	Transmission line type	RS-485 compatible, 5-wire / 3-wire, bus type
	Mode	Half-duplex
	Synchronization method	Asynchronous communication
	Maximum cable length	500m max.
	Terminating resistor	150Ω terminating resistors should be installed at both ends of the bus if necessarily.
	Transmission speed	9600 bps, 19200 bps, 38400 bps
	Bit length	8 bits
	Stop bit length	1 bit
	Parity bit	Even parity
	Connector	Terminal
	Bit rate error	withtin 2.0%
	Communication protocol	CPL
Host communication 3	Transmission line type	Ethernet, IEEE802.3, 10BASE-T
	Mode	CSMA / CD
	Maximum cable length	100 m / segment
	Terminating resistor	Not required.
	Transmission speed	10Mbps
	Number of ports	4 ports
	Number of connections	Up to 8 lines (Total number of all ports)
	Connector	10BASE-T modular jack, RJ-45 connector
	Communication protocol	TCP / IP (Transfer protocol), CPL (Application protocol), Protocol for loader communication (Application protocol)

■ Outside dimensions

Unit: mm

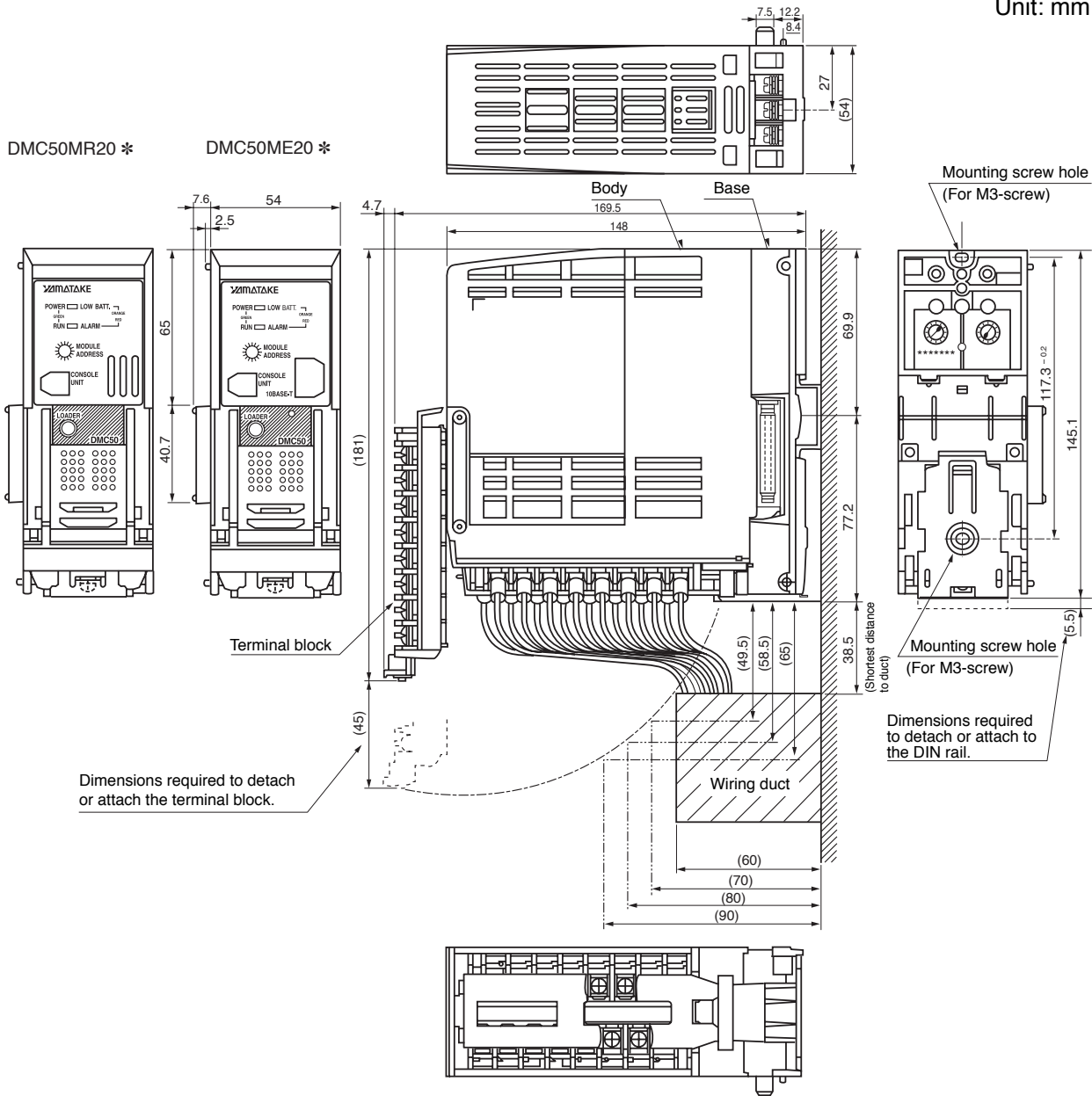

APPENDIX

System Status bit data

This System Status is 32-bit data showing the alarm status of this module.

The following describes the details of the System Alarms bit data:

■ System Alarms

Bit	Alarm name	When detected	Description	Corrective actions
0	Calibration data error	Every time the power is turned ON.	<ul style="list-style-type: none"> It has been detected that an error has occurred in the calibration data copied from the non-volatile memory to RAM. In the ME20X module, the MAC address is stored as calibration data. 	<ul style="list-style-type: none"> Contact Yamatake's local sales representative.
1	System Parameter error	During operation	<ul style="list-style-type: none"> The System Parameters backed up in memory have been corrupted. 	<ul style="list-style-type: none"> Download the application again. If the same error occurs after the application has been downloaded again, contact Yamatake's local sales representative.
2	Reserved.			
3	Reserved.			
4	Reserved.			
5	Reserved.			
6	Reserved.			
7	Reserved.			
8	Reserved.			
9	Reserved.			
10	Reserved.			
11	Reserved.			
12	Reserved.			
13	Reserved.			
14	Reserved.			
15	Reserved.			
16	Board configuration error	Every time the power is turned ON.	<ul style="list-style-type: none"> Hardware (printed circuit board) combination not matching any valid module model has been detected. 	<ul style="list-style-type: none"> Contact Yamatake's local sales representative.
17	Battery voltage drop	Intervals of 100 ms	<ul style="list-style-type: none"> Voltage drop of the battery used for backing up data in RAM has been detected. 	<ul style="list-style-type: none"> DO NOT replace the battery yourself. Contact Yamatake's local sales representative.
18 to 31	Reserved.			

Logging capability

■ About logging capability

This module automatically performs logging of three data; status code, year / month / day, and hour / minute / second of alarm generation / reset of the System Status (System Alarms). Each alarm record is logged into the corresponding Log Parameter(System Alarm Log). By reading this data, the alarm log can be checked.

■ Update time and the number of logging records

- The logging capability is always active.
- Newest 16 occurrences of alarm record are stored. The log data is updated through the ring buffer structure. The latest data is judged by the latest log number and time stamp. (The data is not sorted automatically by the time stamp.)
- Status change of alarms is checked at intervals of 100 ms. At that time, if the alarm data becomes different from the previous log data, it is determined that a new alarm has been generated or the alarm has been reset, and then the alarm log is updated automatically.
- As the log is updated, the value of the latest log number increments and relevant record containing status code, year / month / day, and hour / minute / second items are added automatically.
- To clear the log data, write "0" to [Latest Log Number]. As the value is set to "0", all the [Contents], [Year / Month / Day], and [Hour / Min / Sec] items of 16 are cleared to "0".

Parameter data types

■Parameter data types

The following shows the data types of Parameter elements, which are data specially designed for the DMC50:

Data type	Contents	Range
BOOL	Boolean value	0 to 1(0: FALSE,1: TRUE)
DINT	Double-precision integer	-2147483647 to +214748647
DWORD	32-bit binary	0 to FFFFFFFFh
REAL	Real number	Approximately 10^{-38} to 10^{38} (7-digit precision)

Note

- The following Parameters are provided in this module:
 - System Parameters
 - System Monitor Parameters
- Data type of each Parameter item can be found in the relevant Parameter table.
- DINT type is 32-bit signed integer data. Note that the range is started from "-2147483647".
- DWORD type is 32-bit data. This data is normally used to handle binary images, such as bit data.
- REAL type is 32-bit floating-point (single precision) data in conformity with IEEE 754.

Specifications are subject to change without notice.

YAMATAKE

Yamatake Corporation

Control Products Division

Head office : Totate International Building
2-12-19 Shibuya Shibuya-ku Tokyo 150-8316 Japan

Inquiries to : International Business Division

Phone : 81-3-3486-2331, Fax : 81-3-3486-2300 (Sales)

Phone : 81-466-20-2307, Fax : 81-466-27-9264 (Customer Service)

<http://www.yamatake.com>

This has been printed on recycled paper.

Printed in Japan.
1st Edition: Issued in Dec., 2002(N)

Description change based on the European standards revision

The descriptions in this User's Manual have been changed due to the European standards revision.

The changes are as follows:

1. SAFETY REQUIREMENTS

- “EN61326-1-1997, AI-1998” or equivalent mentioned in the APPLICABLE STANDARDS has been changed to “EN61326”.
- “Installation category: Category II (IEC664-1, EN61010-1)” in the EQUIPMENT CONDITIONS has been changed to “Over-voltage category: Category II (IEC60364-4-443, IEC60664-1)”.
- “Specifications of common mode voltage: The common mode voltages of all I/O except for main supply and relay outputs are less than 30Vrms, 42.4V peak and 60Vdc” in the EQUIPMENT INSTALLATION has been changed to “Specifications of common mode voltage: The common mode voltages of all I/O except for main supply and relay outputs are less than 33Vrms, 46.7V peak and 70Vdc”.

2. SPECIFICATIONS

“Altitude: Max. 2000m” has been added in the OPERATING CONDITIONS.

3. WIRING

Two cautions have been added in the WIRING PRECAUTIONS.

- Devices and systems to be connected to this unit must have the basic insulation sufficient to withstand the maximum operating voltage levels of the power supply and input/output parts.
- Use power supply with reinforced insulation for DC model.