

## Distributed Multi-channel controller DMC10S/DMC10D User's Manual



Thank you for purchasing the Distributed Multi-channel controller DMC10S/ DMC10D.

This manual describes only precautions for ensuring correct use of the Distributed Multi-channel controller DMC10S/DMC10D, specifications and wiring.

Be sure to keep this manual nearby for handy reference.

For further details on correct use, read the Distributed Multi-channel controller DMC10 User's Manual (Description of Functions Version) CP-UM-5143E.

### RESTRICTIONS ON USE

This product has been designed, developed and manufactured for general-purpose application in machinery and equipment.

Accordingly, when used in applications outlined below, special care should be taken to implement a fail-safe and/or redundant design concept as well as a periodic maintenance program.

- Safety devices for plant worker protection
- Start/stop control devices for transportation and material handling machines
- Aeronautical/aerospace machines
- Control devices for nuclear reactors

Never use this product in applications where human safety may be put at risk.

### REQUEST

Make sure that this User's Manual is handed over to the user before the product is used.

Copying or duplicating this User's Manual in part or in whole is forbidden. The information and specifications in this User's Manual are subject to change without notice. Considerable effort has been made to ensure that this User's Manual is free from inaccuracies and omissions. If you should find any inaccuracies or omissions, please contact Yamatake Corporation.

In no event is Yamatake Corporation liable to anyone for any indirect, special or consequential damages as a result of using this product.

©2000 Yamatake Corporation ALL RIGHTS RESERVED

### SAFETY PRECAUTIONS

Safety precautions are for ensuring safe and correct use of this product, and for preventing injury to the operator and other people or damage to property. You must observe these safety precautions. Also, be sure to read and understand the content of this user's manual.



## WARNING

Warnings are indicated when mishandling this product might result in death or serious injury to the user.



## CAUTION

Cautions are indicated when mishandling this product might result in minor injury to the user, or only physical damage to this product.



### CAUTION

- Before wiring or installing the DMC10S/DMC10D, be sure to turn the power OFF.  
Failure to do so might cause the DMC10S/DMC10D to malfunction.
- Do not disassemble the DMC10S/DMC10D.  
Doing so might cause faulty operation.
- Use the DMC10S/DMC10D within the operating ranges (temperature, humidity, vibration, shock, mounting direction, atmosphere, etc.) recommended in the specifications.  
Failure to do so might cause fire or faulty operation.
- Do not block ventilation holes.  
Doing so might cause fire or faulty operation.
- Wire the DMC10S/DMC10D properly according to predetermined standards.  
Also wire the DMC10S/DMC10D using designated power leads according to recognized installation methods.  
Failure to do so might cause electric shock, fire or faulty operation.
- Do not allow lead clippings, chips or water to enter the DMC10S/DMC10D case.  
Doing so might cause fire or faulty operation.
- Firmly tighten the terminal screws at the torque listed in the specifications.  
Insufficient tightening of terminal screws might cause fire.
- Do not use unused terminals on the DMC10S/DMC10D as relay terminals.  
Doing so might cause electric shock, fire or faulty operation.
- Use Yamatake Corporation's SurgeNon if there is the risk of power surges caused by lightning.  
Failure to do so might cause fire or faulty operation.
- When disposing of the DMC10S/DMC10D, dispose of it appropriately as industrial waste in accordance with bylaws and regulations.
- Use the relay on the DMC10S/DMC10D within the rated life described in the specifications. Continued use of the DMC10S/DMC10D outside of the rated life might cause fire or faulty operation.
- The DMC10S/DMC10D will not function for about ten seconds after turning the power ON. Pay attention to this when using the relay output from the DMC10S/DMC10D as an interlock signal.
- Prevent the total power consumption of all linked modules from exceeding 100W.  
Failure to do so might cause fire or faulty operation.
- Do not supply power from two or more lines to all linked modules.  
Doing so might cause fire or faulty operation.
- Connect only one DMC10S/DMC10D to all linked modules.  
Failure to do so might cause the DMC10S/DMC10D to malfunction.
- Do not short the control output section (at voltage pulse output). Doing so might activate the overcurrent protection circuit for the internal power supply, and reset the DMC10S/DMC10D.

## 1. Model Selection Guide

Basic Model No	Number of Channels	Wiring Method	Control Output	Option	Additional Processing	Specifications
DMC10S						Standard model
DMC10D						Advanced function model *1
	2					2-channel input *2
	4					4-channel input *3
		T				Terminal wiring
		C				Connector wiring
			R			Relay output
			V			Voltage pulse output (for SSR drive)
				00		None
				01		2 CT inputs, 4 event relay outputs
				02		2 CT inputs, 4 external switch inputs
				03		2 AUX outputs, 4 event relay outputs
				04		2 AUX outputs, 4 external switch inputs
				05		2 CT inputs, 2 event relay outputs, 2 event voltage outputs
				06		2 CT inputs, 2 external switch inputs, 2 event voltage outputs
					00	None
					D0	Inspection Certificate provided
					Y0	Complying with the traceability certification

\*1: When the advanced model is selected, you can select options "05" and "06".

\*2: When 2-channel input is selected, option "00" cannot be selected.

\*3: When 4-channel input is selected, the wiring method is fixed to "C", and option "00" is fixed.

## 2. Names and Functions of Parts

### Body

#### Loader jack:

Used for connecting the special cable packaged with the Smart Loader Package SLP-D10J20 (provided separately) for performing setup and monitoring on the Loader.

#### Rotary switch for device address:

Sets the address used for host communications.

0 : Communications disabled  
1 to F : Communications enabled

#### POWER lamp:

Lights when power is being supplied (factory setting). Blinks for approx. 10 seconds for initialization after the power is turned ON.

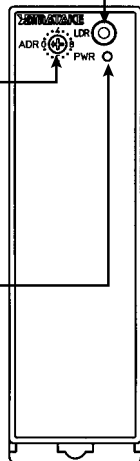

### Base

#### Mounting holes (2 locations):

For securing the base with M3 screws

#### Communications disconnection switch:

Used for disabling local CPL communications with devices linked on the left side (factory setting: CONNECT ←) (linked state)

#### Mounting hole:

Used for securing on a DIN rail

**Lever:**  
For securing the body

#### Power supply terminal

No.	Signal
1	24Vdc(+)
2	24Vdc(-)
3	Do not use

#### Local CPL communications terminal:

3-lead RS-485 connector terminal

No.	Signal
4	DA
5	DB
6	SG

## 3. Installation

### Mounting Locations

Avoid installing the DMC10S/DMC10D in the following locations:

- Locations subject to low and high temperature and humidity
- Locations subject to corrosive gases such as sulfide gases
- Locations subject to dust or oil smoke
- Locations subject to direct sunlight, wind or rain
- Locations subject to vibration or shock
- Locations under high-voltage lines and near sources of electrical noise such as welders
- Locations within 15 meters of high-voltage ignition equipment such as boilers
- Locations where magnetic fields are generated
- Locations near flammable liquid or steam

### Linking modules

The DMC10S/DMC10D can be linked with other modules by the connectors on the left and right of the base. Modules must be linked before the DMC10S/DMC10D is mounted on the DIN rail or mounted by screws.

By linking modules together, the power supply of each module and CPL communications are connected, eliminating the need for wiring.

CPL communications can be disconnected by the communications disconnection switch on the base.

### Installation Procedure

The DMC10S/DMC10D can be mounted in either of two ways, by mounting its base by screws or by securing on a DIN rail.

#### When mounting the base by screws

Secure the two mounting holes on the base by M3 screws.

#### When securing on a DIN rail

Secure the DMC10S/DMC10D on the DIN rail, fully draw out the DIN rail stopper and hook the base onto the DIN rail. Next, push the mounting lever upwards until you hear it click into place.

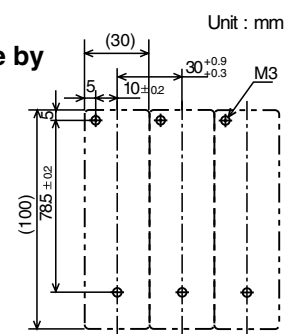

## ■ Mounting the body on the base

Fit the hook into the base and push the body into the base until you hear it click into place.

To remove the body from the base, pull the body towards you while pressing down the lever.

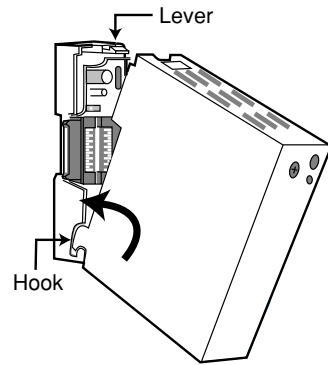

## 4. Wiring

### ■ Wiring Precautions

- Check the model number of the controller and terminal numbers on the label on the side of the controller to prevent any wiring errors.
- Use crimped terminals for M3.5 screws to connect terminals.
- Prevent crimped terminals from coming into contact with adjacent terminals.
- I/O signal lines should be routed at least 50 cm away from power lines. Also, do not route I/O leads through the same distribution box or ducts.
- Before connecting in parallel to other equipment, thoroughly check the conditions of the other equipment.
- Pass a lead wire for carrying the heater current through a current transformer. Do not use a heater current that exceeds the allowable current described in the specifications. Doing so might damage the DMC10S/DMC10D.
- The controller is designed not to function for ten seconds after the controller is turned ON. This is to allow it to stabilize. The controller then enters the Run mode. However, allow at least 30 minutes for the controller to warm up so that the specified accuracy is satisfied.
- When wiring is finished, check the connections for any miswiring before turning the power ON.

### ■ Connecting the Power Supply

Connect the power terminal as follows:

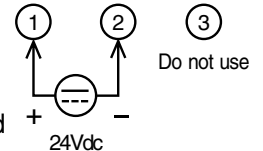

### ! Handling Precautions

- Power is mutually connected between linked modules.
- Supply power to one of the linked modules.
- Select a power supply that can cover the total power consumption of all linked modules.

### ■ Connecting CPL communications

CPL communications (RS-485) is performed using a 3-lead connection.

\* CPL (Controller Peripheral Link) communications network is the Yamatake Corporation's host-communications.

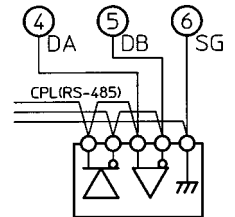

Ex: Connection with a 5-lead device

### ! Handling Precautions

Do not connect an external terminating resistor as the DMC10S/DMC10D has a built-in resistor equivalent to a terminating resistor.

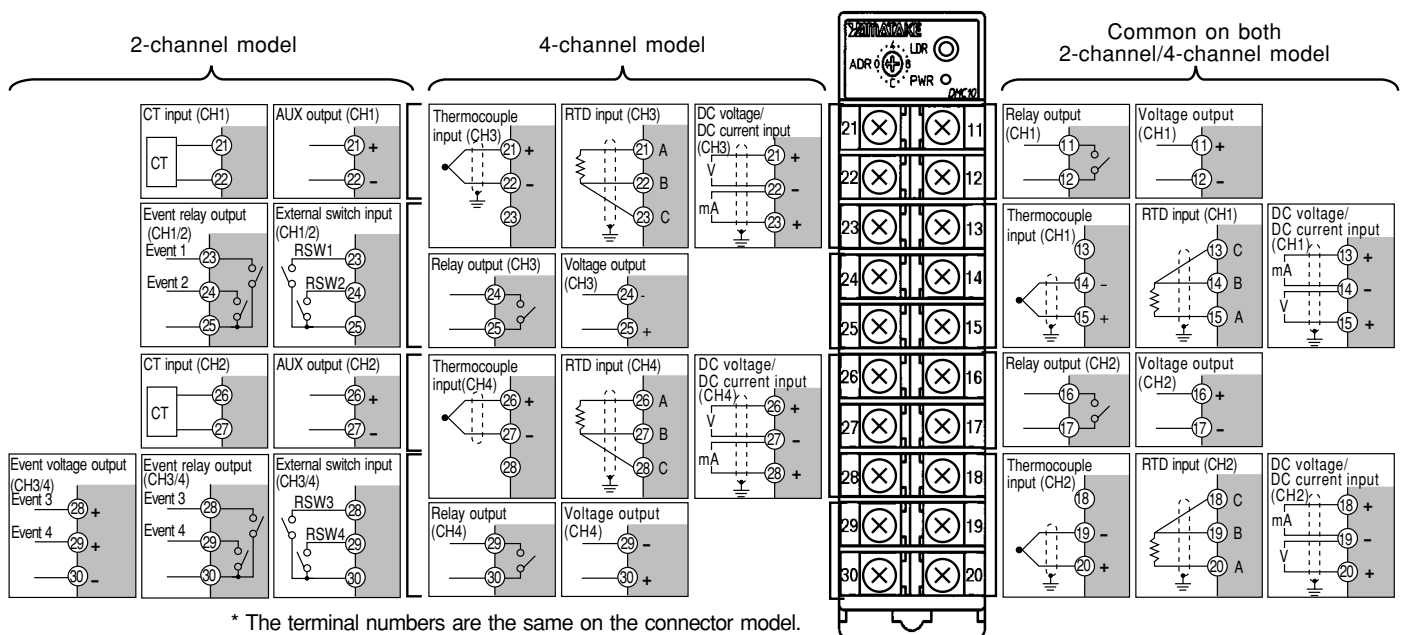

\* The terminal numbers are the same on the connector model.

## 5. Specifications

### ■ Isolation of DMC10S/DMC10D

Dotted lines in the following figure mean non-isolated areas:

PV CH1	Power supply	OUT CH1 *1
PV CH2		OUT CH2 *1
PV CH3		OUT CH3 *1
PV CH4		OUT CH4 *1
RSW CH1	Logic	EVENT CH1
RSW CH2		EVENT CH2
RSW CH3		EVENT CH3 *1
RSW CH4		EVENT CH4 *1
CT CH1	Loader communications	AUX CH1
CT CH2		AUX CH2
		CPL communications

\*1: When a voltage output type is selected, the power supply is not isolated.

### ■ Specifications

Item	Specifications	
PV input	Input type	Thermocouple : K, J, T, E, R, S, DINU, DINL, PLII RTD : Pt100, JPt100 DC voltage : 1 to 5V, 0 to 5V, 0 to 1V DC current : 4 to 20mA
	Accuracy	DMC10S ±0.5% FS ±1 digit ±1% FS ±1 digit for minus area for thermocouples DMC10D ±0.3% FS ±1 digit ±0.6% FS ±1 digit for minus area for thermocouples CJ error at linking with other modules Terminal type: max. ±1°C Connector type: max. ±2°C
	Sampling cycle	500ms
	Isolation between inputs	Yes (Different types can be input for each channel.)
	SP setup	Number of setup points 1 to 8/channel (2-channel model) 1 to 4/channel (4-channel model)
Control output	Output type	Relay contact output      Voltage pulse output (for SSR drive)
	Control action	ON/OFF, time-proportional
	Output rating	Contact type: SPST      Open terminal voltage: Contact rating:      13.0Vdc ±10% 250Vac, 3A, 30Vdc, 3A      Internal resistance: Life: 100,000      150Ω ±5% operations or more      OFF leakage current: (resistive load)      max. 100μA Min. switching      Output current: specification:      max. 30mA 5V, 10mA
Event output	Number of points	2 or 4
	Output type	Relay contact output      Voltage output
	Output rating	Contact type: SPST      Open terminal voltage: Contact rating:      13.0Vdc ±10% 250Vac, 3A, 30Vdc, 3A      Internal resistance: Life: 100,000      150Ω ±5% operations or more      OFF leakage current: (resistive load)      max. 100μA Min. switching      Output current: specification:      max. 30mA 5V, 10mA
	Type of action /optional functions	For details, refer to the Distributed Multi-channel controller DMC10 User's Manual of (Description Functions Version) CP-UM-5143E.
External switch input	Number of points	2 or 4
	Input type	Dry contact input or open collector input Allowable ON contact resistance : max. 250Ω Allowable OFF contact resistance : min. 100kΩ Allowable ON residual voltage : max. 2V Open terminal voltage : 13Vdc ±10% Terminal current when ON : approx. 5mA
Current output (AUX)	Number of points	2 or 4
	Output type	0 to 20mAAdc/4 to 20mAAdc
	Output content	PV, SP, OUT, etc.
	Allowable load resistance	Max. 300Ω
Output accuracy	DMC10S : ±0.5%FS / DMC10D : ±0.3%FS Accuracy not assured at DC1mA or less	

Item	Specifications	
Current transformer input	Number of points	2 or 4
	Measurement range	0.4A to 50.0A
	Accuracy	±5% FS ±1 digit
General specifications	Recording method	Non-volatile semiconductor memory
	Rated power voltage	24Vdc
	Allowable operating voltage range	21.6 to 26.4Vdc
	Power consumption	Max. 5W (in operating state)
	Insulation resistance	Across primary and secondary sides: min. 500Vdc 20Mz
	Dielectric strength	Across primary and secondary sides: 500Vac 1min
	Power ON rush current	Max. 10A
	Case, base material/color	Polycarbonate/light gray (munsell: 2.5Y7.5/1 or equivalent)
	Mass	Max. 200g

### ■ External Dimensions

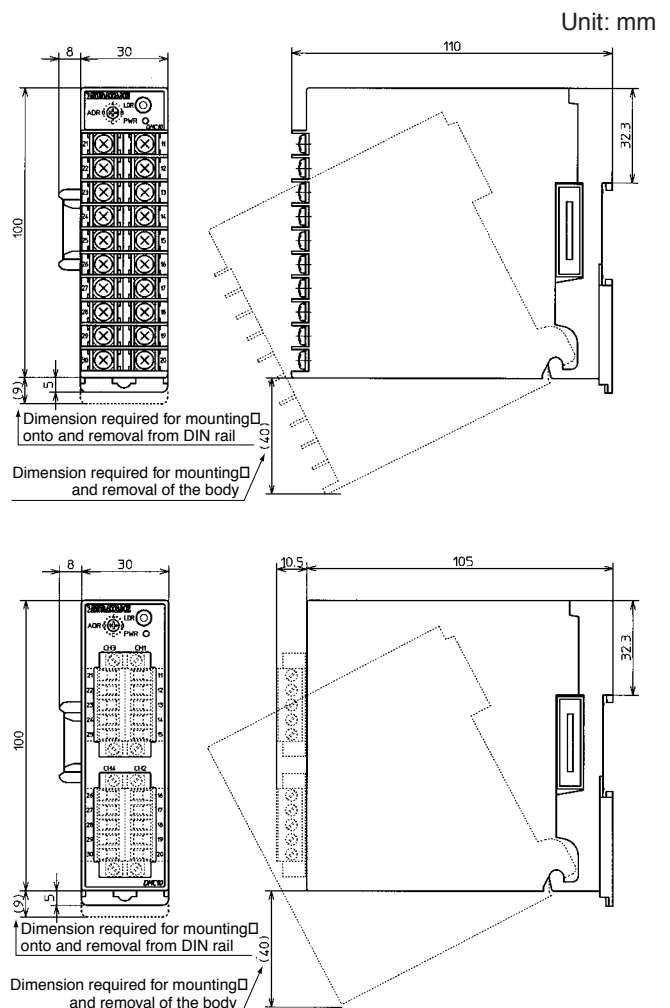

**YAMATAKE**

Specifications are subject to change without notice.

**Yamatake Corporation**  
**Advanced Automation Company**  
**International Business Headquarters**

Totate International Building  
 2-12-19 Shibuya Shibuya-ku  
 Tokyo 150-8316 Japan

URL: <http://www.yamatake.com>

Printed in Japan.  
 1st Edition: Issued in Sep., 2000(C)  
 8th Edition: Issued in Sep., 2003(W)