

## DigitroniK

# Distributed Multi-Channel Controller

## DMC10

The DigitroniK DMC10 is a module type 2 or 4-channel compact digital controller.

Inputs are full multiple, supporting thermocouple, RTD, DC voltage and DC current inputs.

Control mode is time proportional (ON/OFF) PID control. Control outputs are relay output and voltage pulse output. Continuous PID control is attained by an auxiliary output, as an optional function.

A dedicated PC loader configures setup, control parameters and setpoint data.

### ■ Features

- Accuracy of  $\pm 0.5\%FS$
- Sampling cycle of 500ms
- Full multiple input function is equipped, supporting various analog input sensors.
- Communication function (RS-485) is provided as standard. Communication performance is enhanced by supporting 19200bps.
- 30×100×110mm compact size
- Two event outputs are available for each channel. "AND/OR" logic is used as an event between channels by the internal event function. (Under development)
- Current transformer (CT) input is provided for each channel.
- Easy setting by a personal computer loader, also enabling monitoring of trial operation.
- Connector type and terminal type models available for the I/O wiring unit
- A side-face connector is used to connect modules, therefore communication and power wiring is not required.
- "Quick-FITTER" Control, a high-speed recovery control function is equipped as standard. This function enables the quick recovery of setpoint temperature and over-shoot suppression at the occurrence of disturbances.
- CE approval obtained



### ■ DMC10 Basic Function Block Diagram

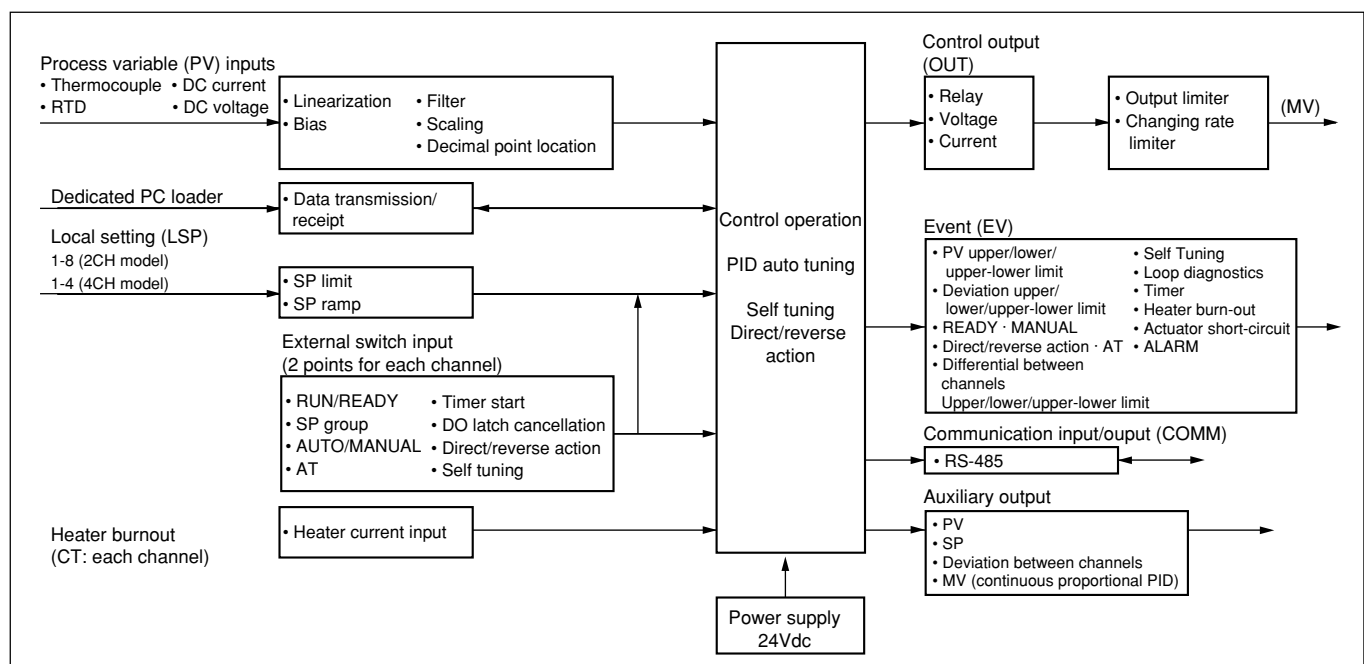

## ■ Specifications

Model No.		DMC10S2T	DMC10S2C	DMC10S4C
No. of control channels		2	2	4
Connection method for external device		Terminal plate	Connector	Connector
PV Input	Input type	Thermocouple, RTD, DC voltage, DC current (see table 1)		
	PV readout accuracy	±0.5%FS ±1 digit (under standard conditions)		
	Cold junction compensation accuracy	Included in PV readout accuracy		
	Sampling cycle	0.5s		
	Input filter	0.0 to 480.0s		
	Input bias current	T/C input: 0.2μA max. (under standard conditions) RTD input: 1mA (typ) DC voltage input: 1V max. ∙ 0.2μV / Ωmax. (under standard conditions) 1 to 5V ∙ 1.5μV / Ωmax. (under standard conditions)		
	Action at burnout	T/C: Upscale RTD: (refer to details on the right) Voltage input: Upscale Current input: Downscale	Sensor element broken: Upscale "A" wire broken: Upscale "B" wire broken: Downscale "C" wire broken: Downscale 2 to 3 wires broken: Downscale A-B wires shorted: Downscale A-C wires shorted: Downscale	
Setting, Indication	Setting method	By dedicated PC loader (SLP-D10J20) or communication program		
	No. of set points	Max. 8 points (2CH model) or max. 4 points (4CH model) for each channel		
	Memory storage	Non-volatile semiconductor memory		
	Device address setting	Front rotary switch		
	Front indication LED	1 point, operation contents settable (lights at power ON at factory shipment)		
Control Output	Type of control output	Relay output	Voltage pulse output	
	Control action	Time proportional PID or ON/OFF control	Time proportional PID or ON/OFF control	
	No. of PID groups	1 group/channel	1 group/channel	
	Output rating	Contact rating: 3A (30Vdc/250Vac, resistive load) Contact type: 1a Minimum switching voltage: 5V Minimum switching current: 100mA Contact life: 100,000 cycles (electrical)	Driving system: Voltage Opening terminal voltage: 13Vdc ± 10% Internal resistance: 150Ω ± 5%	
	Time proportional cycle	5 to 120s	5 to 120s	
	Proportional band (P)	0.1 to 999.9%	0.1 to 999.9%	
	Integral time (I)	0 to 3600s	0 to 3600s	
	Derivative time (D)	0 to 1200s	0 to 1200s	
	Differential gap (ON/OFF control)	1 to 10000 units	1 to 10000 units	
	Output limiter upper limit	Output limiter lower limit to 100.0%	Output limiter lower limit to 100.0%	
	Output limiter lower limit	0.0 to output limiter high limit	0.0 to output limiter high limit	
	Control action changeover	Direct/reverse	Direct/reverse	
	Event Output	No. of outputs	4 (model with event output) 4 (with event output module DMC10E) Event action can be assigned to control output (to be developed) * Max. No. of outputs is 8	
No. of set points		8 (total of external outputs, plus outputs to internal bus)		
Event output types		Upper PV, Lower PV, Upper & Lower PV, Upper DEV, Lower DEV, Upper & Lower DEV, Upper DEV between channels, Lower DEV between channels, Upper & Lower DEV between channels, READY, MANUAL, Direct-Reverse Op, AT, Self-tuning, Loop diagnostics, Timer, Heater Line break/over-current, Heater short-circuit, Individual channel PV alarm, Individual channel alarm		
Differential gap		0 to 10000 units		
Optional functions		Stand-by sequence, latch, delay, AND/OR output (to be developed)		
Output action		ON/OFF		
Output rating		250Vac, 1A or 30Vdc, 1A		
Contact type		Relay output, 1A		
Contact life		100,000 cycles (electrical)		
Minimum switching voltage		5V		
Minimum switching current		10mA		

<b>External Contact Input</b>	<b>No. of input points</b>	4 (model with external contact input) 4 (input from internal bus)		
	<b>Operation types</b>	SP selection, RUN/READY changeover, AUTO/MANUAL changeover auto-tuning start/stop, self-tuning operation timer event start trigger, event output latch cancellation		
	<b>Input type</b>	Dry contact or open collector		
	<b>Opening terminal voltage</b>	13Vdc $\pm$ 10%		
	<b>Allowable contact resistance at ON time</b>	250 $\Omega$ max. (under operating conditions)		
	<b>Allowable contact resistance at OFF time</b>	100k $\Omega$ min. (under operating conditions)		
	<b>Allowable residual voltage at ON time</b>	2V max. (under operating conditions)		
	<b>Allowable leak current at OFF time</b>	100 $\mu$ A max. (under operating conditions)		
	<b>Minimum hold time of ON detection</b>	100ms		
	<b>Insulation</b>	(Refer to isolation drawing)		
<b>Current Transformer Input</b>	<b>No. of inputs</b>	2		
	<b>Measurement range</b>	0.4 to 50.0A		
	<b>Effective setting range</b>	0.4 to 50.0A		
	<b>Current value detection accuracy</b>	$\pm$ 5%FS $\pm$ 1 digit		
<b>Communications</b>	<b>Communication system</b>	<b>Communication protocol</b>	RS-485 (3-wire type)	
		<b>Network</b>	Multi-drop, (slave-station function only provided)	
		<b>Data flow</b>	Half duplex	
		<b>Synchronization</b>	Start/stop synchronization	
		<b>Max. No of connectable units</b>	16 units including host computer	
	<b>Interface system</b>	<b>Transmission system</b>	Balanced (differential)	
		<b>Data line</b>	Bit serial	
		<b>Signal lines</b>	Data transmission and receipt: 3 wires	
		<b>Transmission speed</b>	2400, 4800, 9600, 19200bps selectable	
		<b>Communication distance</b>	500m max.	
		<b>Communication response waiting time</b>	1, 10, 100, 200ms selectable	
		<b>Others</b>	RS-485 compliance (3-wire)	
	<b>Message characters</b>	<b>Format</b>	<ul style="list-style-type: none"> <li>· 8 bit length, even parity and 1 stop bit</li> <li>· 8 bit length, no parity and 2 stop bits</li> </ul>	
	<b>General Specifications</b>	<b>Memory back-up</b>	Non-volatile semiconductor memory	
<b>Rated power voltage</b>		24Vdc		
<b>Allowable power voltage</b>		24Vdc $\pm$ 10%		
<b>Power consumption</b>		DMC10S: 5W max. (under standard conditions) DMC10E: 3W max. (under standard conditions)		
<b>Insulation resistance</b>		20M $\Omega$ min. between power terminal and secondary terminal (by 500Vdc megger)		
<b>Dielectric strength</b>		500Vac, 1 min between power terminal and secondary terminal/case		
<b>Standard conditions</b>		<b>Ambient temperature</b>	23 $\pm$ 2 $^{\circ}$ C	
		<b>Ambient humidity</b>	60 $\pm$ 5%RH	
		<b>Vibration resistance</b>	0m/s $^2$	
		<b>Shock resistance</b>	0m/s $^2$	
		<b>Mounting angle</b>	(Reference plane) $\pm$ 3 $^{\circ}$	
<b>Operating conditions</b>		<b>Ambient temperature</b>	0 to 50 $^{\circ}$ C	
		<b>Ambient humidity</b>	10 to 90%RH (no condensation allowed)	
		<b>Vibration resistance</b>	0 to 2m/s $^2$ (10 to 60Hz, 2hr each in X, Y and Z directions)	
		<b>Shock resistance</b>	0 to 10m/s $^2$ (3 times in each direction when panel mounted)	
		<b>Mounting angle</b>	(Reference plane) $\pm$ 10 $^{\circ}$	
<b>Transport/storage conditions</b>		<b>Ambient temperature</b>	-20 to +70 $^{\circ}$ C	
		<b>Ambient humidity</b>	10 to 90%RH (no condensation allowed)	
		<b>Vibration resistance</b>	0 to 5m/s $^2$ (10 to 60Hz, 2hr each in X, Y and Z directions)	
		<b>Shock resistance</b>	0 to 392m/s $^2$ (3 times in each direction when screw mounted) 0 to 196m/s $^2$ (3 times in each direction when DIN rail mounted)	
		<b>Package drop test</b>	Drop height: 60cm (1 angle, 3 edges, 6 planes) free fall	
<b>Case material</b>		Polycarbonate resin		
<b>Mounting</b>	DIN rail or screw mount			
<b>Environment for use</b>	Avoid rusting gases and accumulated dust			
<b>Accessories</b>	User's manual			
<b>Weight</b>	200g			

**Table 1 Input type and ranges**

Input type	Sensor	Range No.	Temperature range (°C)	Accuracy (±%FS)
Thermo-couple	K	01	0 to 1200	0.5
		02	0 to 600	0.5
		03	0 to 400	0.5
		04	-200 to 0	1.0
	J	05	0 to 800	0.5
		06	-200 to 0	1.0
	E	07	0 to 600	0.5
	T	08	-200 to 0	1.0
	DINU	09	-200 to 0	1.0
	DINL	10	0 to 800	0.5
	R	11	0 to 1600	0.5

Input type	Sensor	Range No.	Temperature range (°C)	Accuracy (±%FS)
RTD	Pt100	21	-200 to +500	0.5
		23	0 to 200	0.5
		28	-50 to +100	0.5
	JPt100	24	-200 to +500	0.5
		26	0 to 200	0.5
		30	-50 to +100	0.5
		Current	41	4 to 20mA
Voltage	42	1 to 5V	0.5	
	43	0 to 5V	0.5	
	44	0 to 1V	0.5	

## ■ Event Output Module Specifications

### ● Features

- The number of event outputs can be added in combination with the DMC10.
- One event module can be connected to a side-connection gang-mounted group.
- By adding an event output module, this unit can respond to a wide variety of temperature control application requirements.



Model No.	DMC10E
No. of inputs	4
Output action	ON/OFF
Contact type	Relay output 1a × 2 points, 1c × 2 points
Output rating	250Vac, 1A or 30Vdc, 1A
Contact life	100,000 cycles (electrical)
Minimum switching voltage	5V
Minimum switching current	10mA
Operation types	Upper PV, Lower PV, Upper & Lower PV, Upper DEV, Lower DEV, Upper & Lower DEV, Upper DEV between channels, Lower DEV between channels, Upper & Lower DEV between channels, READY, MANUAL, Direct-Reverse Op, AT, Self-tuning, Loop diagnostics, Timer, Heater Line break/over-current, Heater short-circuit, Individual channel PV alarm, Individual channel alarm
Differential gap	0 to 10000 units
Optional function	Stand-by sequence, latch, delay, AND/OR output (to be developed)
Setting method	Assign the internal bus output of the DMC10S
Mounting method	Connectable by a side connector, same as DMC10S
No. of connectable units	Up to one unit per group can be connect by a side-connector DMC10S : DMC10E=N :1
Power voltage	24Vdc ± 10%
Power consumption	3W

## ■ Model Selection Guide

### ● 2-Channel type

I II III IV V VI VII

Example: DMC10S2TR0100

I	II	III	IV	V	VI	VII	Description
Basic model No.	Type	No. of channels	Wiring method	Control output	Options	Additional processing	
DMC10	S	2	T	C	R	V	Multi-channel controller
							Standard function
	2 channels						
	Terminal wiring						
	Connector wiring						
	Relay output						
	Voltage pulse output						
	01	4 Event outputs, 2 current transformer inputs					
	02	4 External contact inputs, 2 current transformer inputs					
	03	4 Event outputs, 2 continuous proportional PID (4-20mA 300Ω Max.)					
	04	4 External contact inputs, 2 continuous proportional PID (4-20mA 300Ω Max.)					
	00	None					
	D0	Inspection certificate					
	Y0	Traceability certificate					

### ● 4-Channel type

I II III IV V VI VII

Example: DMC10S4CR0000

I	II	III	IV	V	VI	VII	Description
Basic model No.	Type	No. of channels	Wiring method	Control output	Options	Additional processing	
DMC10	S	4	C	R	V	00	Multi-channel controller
							Standard function
	4 channels						
	Connector wiring						
	Relay output						
	Voltage pulse output						
	None						
	00	None					
	D0	Inspection certificate					
	Y0	Traceability certificate					

## ■ Peripheral Device Model Numbers

### ● Event Output Module

I II III IV V VI VII

Example: DMC10E4CR0000

I	II	III	IV	V	VI	VII	Description
Basic model No.	Type	No. of channels	Wiring method	Control output	Options	Additional processing	
DMC10	E	4	C	R	00	00	-
							Event output module
	4 channels						
	Connector wiring						
	Relay output						
	None						
None							

### ● PC loader software

I II

Example: SLP-D10J20

I	II	Description
Basic model No.	Option	
SLP-D10		PC Loader for DMC10
	J20	Japanese version (with dedicated cable)

\*PC/AT converter complies with Windows 95/98

## ■ Dimensions

### ● DMC10S2T□□□□

(Unit: mm)

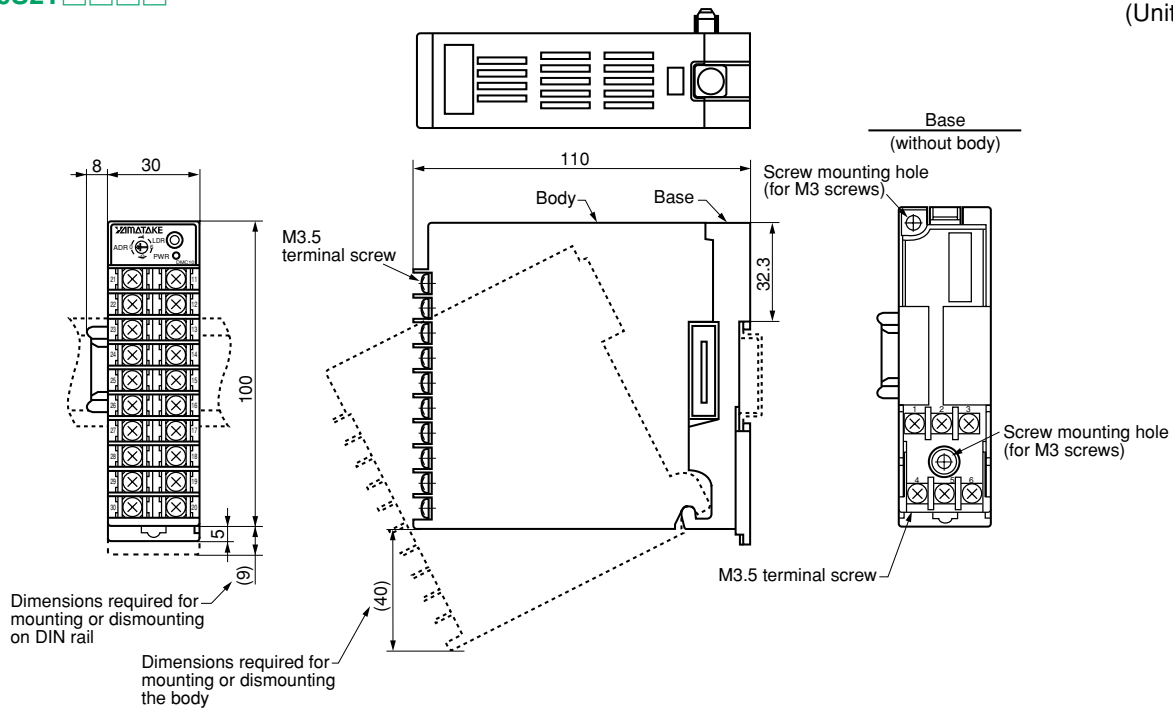

### ● DMC10S□C□□□□, DMC10E (Event output module)

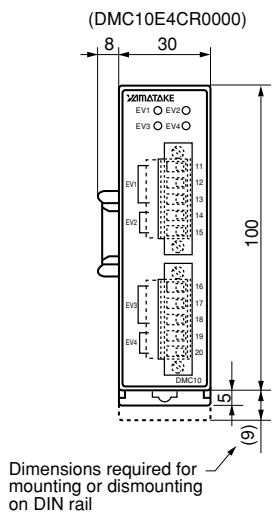
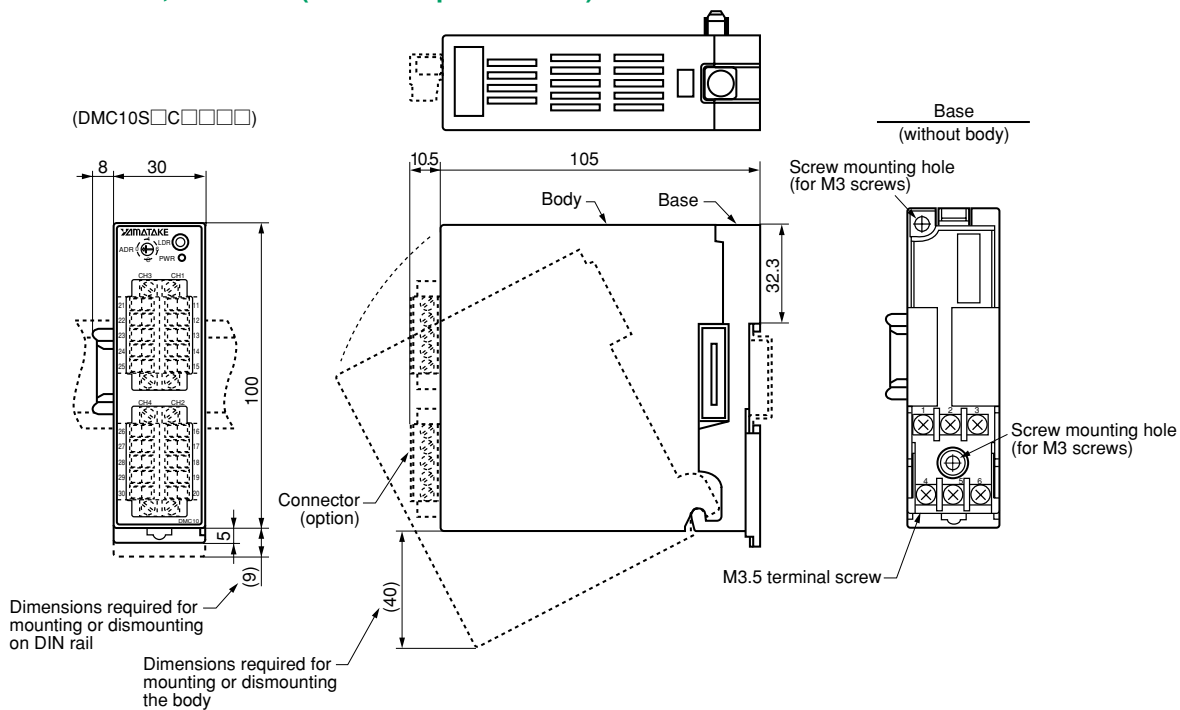

## ■ Wiring

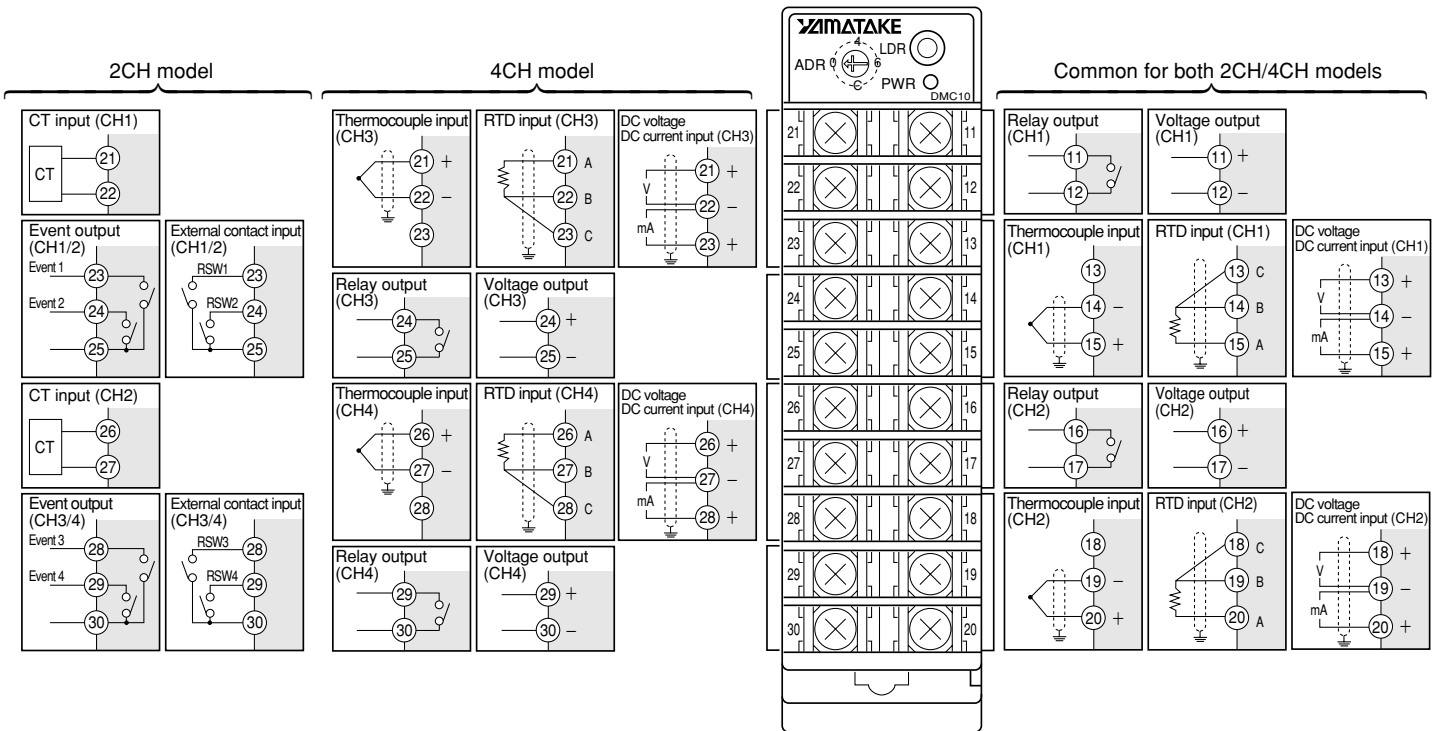

Note: Terminal numbers are the same for both connector and terminal plate types.

## ■ Connecting Power

Connect the power terminals, as shown below

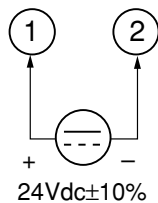

### ! Handling Precautions

- Power is jointly connected between linked modules
- Apply power to any of the connected modules
- Select power which can fully support the total power consumption for all modules

## ■ Wiring Precautions

- Before wiring, confirm the model No. and terminal numbers on the attached label (side-face)
- Be sure to use crimp-style terminals adaptive to M3.5 terminal screws.
- Ensure that the crimp-style terminals do not contact the adjacent terminals.
- Maintain a distance of at least 50cm between the I/O signal leads and the power lead. Also, do not pass these leads through the same piping or wiring duct.
- When connecting in parallel with other instruments, be sure to check the conditions of the peripheral products before installation.

## ■ Connecting CPL Communications

3-wire type connection of CPL communications (RS-485)

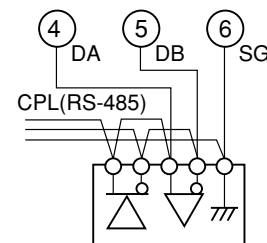

Example: Method to connect with a 5-wire type instrument

### ! Handling Precautions

Do not externally connect a terminating resistor, as a resistance equivalent is already provided.

- Pass the heater-current leads through the current transformer. Do not use the heater-current in excess of the allowable current specified in the specification table. In doing so, this device may malfunction.
- This device is designed so as not to function for a maximum of 10 seconds after application, for safety purposes. The device status then moves to operation, before a warm-up period of more than 30 minutes in order to comply with the specified accuracy.
- After wiring is completed, be sure to inspect and check the wiring state before supplying power, to ensure that there is no wiring error.

## ■ Dimensions for Mounting with Screws

(Unit: mm)

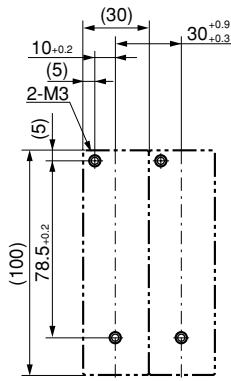

## ■ Name of Each Unit and Function

### ● Body

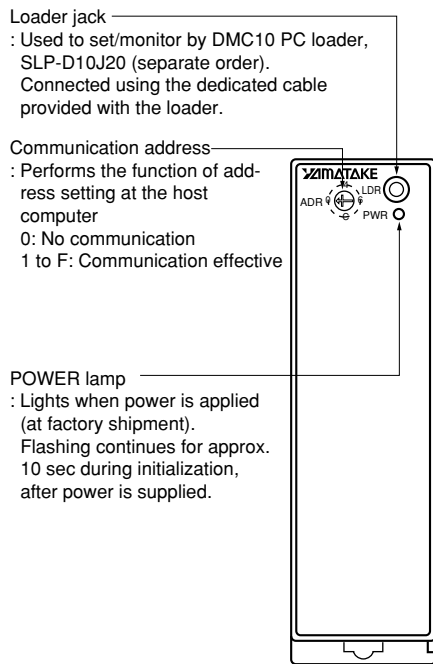

### ● Base

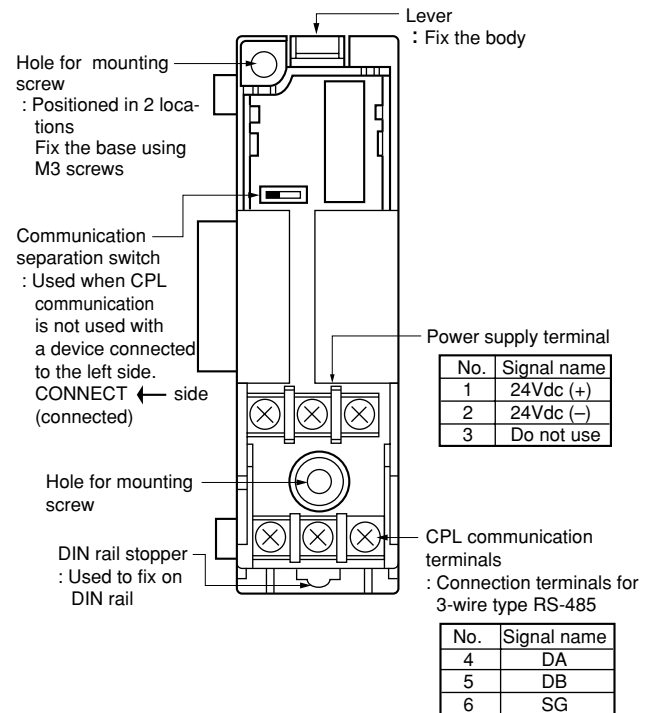

## ■ Connecting Module

This device can be connected to other modules, using connectors provided on both the left and right sides. Be sure to connect the module before mounting on DIN rail or by screws. Power and CPL communications are jointly connected between lined modules, saving wiring. CPL communication can be separated by a communication separation switch at the base.

## ■ Precautions on Installation

### ● Location for Installation

Mount the instrument at a location that satisfies the following conditions:

- Mount the instrument in location: Not subject to high or low temperatures, or high or low humidity.
- Free of corrosive gas (sulfide gas, etc.)
- Free of dust particles, soot, or the like.
- Not exposed to direct sunlight, rain or wind
- Free of mechanical vibrations and shock
- Do not mount the instrument near a high-voltage line, a welder, or electrical noise generating sources
- Make sure the instrument is within 15m from a boiler or other high-voltage ignition devices.
- The location should not be subject to a strong magnetic field.
- Where flammable liquid or steam does not exist.

## ■ Isolated areas

Solid line — indicates isolated area.

Broken line - - - - indicates areas that are not isolated.

PV CH1	Power	OUT CH1 *1
PV CH2		OUT CH2 *1
PV CH3		OUT CH3 *1
PV CH4		OUT CH4 *1
RSW CH1		EVENT CH1
RSW CH2		EVENT CH2
RSW CH3		EVENT CH3
RSW CH4		EVENT CH4
CT CH1	Logic	CPL communication
CT CH2		
Loader communication		

\*1: Voltage output type is not isolated with power

 **RESTRICTIONS ON USE**

This product has been designed, developed and manufactured for general-purpose application in machinery and equipment. Accordingly, when used in the applications outlined below, special care should be taken to implement a fail-safe and/or redundant design concept as well as a periodic maintenance program.

- **Safety devices for plant worker protection**
- **Start/stop control devices for transportation and material handling machines**
- **Aeronautical/aerospace machines**
- **Control devices for nuclear reactors**

Never use this product in applications where human safety may be put at risk.

*Specifications are subject to change without notice.*

**YAMATAKE**

**Yamatake Corporation**  
**Advanced Automation Company**  
**International Business Headquarters**

Totate International Building  
2-12-19 Shibuya Shibuya-ku  
Tokyo 150-8316 Japan

URL:<http://www.yamatake.com>

*This has been printed on recycled paper.* (01)

Printed in Japan. (H)  
1st Edition: Issued in Sep., 1996  
2nd Edition: Issued in May, 2003