

Electromagnetic calorimeter Model MCM10A

OVERVIEW

The Yamatake model MCM10A is a custody transfer meter used to measure the calorie consumption of air conditioning systems in buildings or shopping malls or it can be used in district heating/cooling applications.

The flow rate is measured by an electromagnetic magnetic flow meter having field proven Yamatake technologies.

It measures the flow rate of chilled water/water with glycol/hot water and calculates calorie consumption with its two temperature inputs (supply and return).



Nominal size: 25 to 100 mm

ADVANTAGES

Reduced total cost of ownership

No additional computing system for calorie consumption calculation is necessary.

Precise cooling/heating cost measurement

Yamatake electromagnetic flow meter technology ensures accurate flow measurement.

Its temperature sensor compensation function provides accurate calorie consumption measurement.

Energy efficient

No pressure loss occurs with the electromagnetic flow meter thus resulting in less energy required for the flow.

FEATURES

- The Yamatake model MCM10A has a calorie consumption calculation program.
- It has two terminals for the temperature sensor (Pt 100 Ω RTD sensor) input (supply and return).
- The device is provided with two types of output, analog (4 to 20mA) and pulse output (totalized value).
- The Yamatake model MCM10A accumulates the totalized values of calorie consumption for both cooling and heating modes.

Applications

Buildings / Shopping malls

Calorie consumption measurement for air conditioning systems

District heating/cooling

Calorie consumption measurement

For converter**FUNCTIONAL SPECIFICATIONS****Type of protection**

IEC IP65 (for indoor use)

Input signal**Temperature** (two inputs: supply and return)3-wire Pt 100 Ω sensor

IEC751 "Tolerance class A" is recommended.

Output signal**Analog output**

4 to 20mA DC (flow rate)

Load resistance: 0 to 400 Ω **Pulse output**

Open collector (calorific value consumption)

Contact capacity: 30 V DC max., 100mA max.

Pulse frequency: 500 Hz max.

Pulse width: 1ms to 1s

Adjustable between 1ms and 1s or fixed at 50% of

duty.

Pulse scale: 0.01, 0.1, or 1 in the selected calorific unit.

Calorific unit

GJ, MJ, Gcal, Mcal, MBTU, kBTU

Display**Display: LCD**

Main display: 7-segment, 8 digits for totalized calorific value of consumption.

Sub display: 16 digits, 2 lines for mode indication, % flow rate, calorific unit, and supply and return fluid temperatures.

Data setting

Operation by four key switches.

Damping (for flow rate)

Adjustable between 0.5 and 199.9 seconds.

Low flow cutoff (for flow rate)

Adjustable from 0 to 10% of the setting range.

If below the selected value, the output will be driven to the zero flow rate signal level.

Dropout (for flow rate)

Adjustable from 0 to 10% of the setting range.

If below the selected value, the pulse output will be cut.

Empty pipe detection

If the detector is empty, analog output and pulse output will be fixed at zero. The flow rate on the display will be zero and "EMPTY" will be written on the display.

Temperature sensor compensationBy inputting resistances at 0°C and 100°C, the deviation of two Pt 100 Ω sensors (supply and return) is cancelled.**Failure diagnostics**

If the converter malfunctions, the analog output will be automatically fixed at 3.6mA.

Power failure

An EEPROM retains a data record of the totalized values of the consumed calorific value for both cooling and heating modes.

Power supply24 V DC \pm 10%**Power consumption**

2.4 W max.

Ambient temperature limits

0 to 50°C

Ambient humidity limits

5 to 85% RH (no condensation)

Optional specifications**Traceability certificate**

The following three documents are included.

- Trace-ability system chart
- Trace-ability certificate
- Test report

PHYSICAL SPECIFICATIONS**Case material**

Polycarbonate

Case cover material

Polycarbonate

INSTALLATION**Cable gland**

Plastic gland (5 pieces)

Cable

Applicable cable outer diameter

Power supply/outputs: ϕ 6 to ϕ 12 mmTemperature sensor inputs: ϕ 4 to ϕ 8 mm

Applicable cable conductor

Power supply:

AWG 14 to 22 (0.32 to 2.03 mm²)

Outputs/temperature sensor inputs:

AWG 16 to 26 (0.13 to 1.31 mm²)**Mounting**

Integral only

GroundingGrounding resistance should be less than 100 Ω .

For detector

FUNCTIONAL SPECIFICATIONS**Type of protection**

IEC IP65 (for indoor use)

Temperature range of process fluid

-20 to 90°C

Pressure range of process fluid2.0 MPa max. (20 kgf/cm² max.)**Measurable process fluid**

Chilled water, water with glycol, hot water (no corrosive fluid, no abrasive fluid)

Measurable electrical conductivity

50 µS/cm min.

Measurement flow range**Table 1 Measurement flow range**

Size (mm)	Minimum range (m ³ /h)	Maximum range (m ³ /h)
25	0 to 1.768	0 to 8.835
40	0 to 4.524	0 to 22.619
50	0 to 7.069	0 to 35.342
65	0 to 11.946	0 to 52.729
80	0 to 18.096	0 to 90.477
100	0 to 28.275	0 to 141.371

Size

25, 40, 50, 65, 80, 100 mm

Flange rating

JIS 10K, JIS 20K, ANSI150, DIN PN10, DIN PN16

Ambient temperature limits

0 to 50°C

Ambient humidity limits

5 to 85%RH (no condensation)

Test reports (for flow meter only)

Calibration certificate, withstand voltage test, insulation resistance hydrostatic pressure test, and physical inspection are included.

PERFORMANCE SPECIFICATIONS**Accuracy (flow rate)**

Vf = velocity of process fluid

Vf (m/s)	Accuracy
$1 \leq Vf \leq 5$	± 0.5% of rate
$Vf < 1$	± 0.5% of span

PHYSICAL SPECIFICATIONS**Main body materials****Case material**

SUS304 stainless steel

Measuring pipe material

SUS304 stainless steel

Process wetted materials**Lining**

Polypropylene

Electrode

SUS316L stainless steel

Grounding ring (downstream side only)

SUS304 stainless steel

INSTALLATION**Pipe connection**

Wafer style

Grounding

Grounding resistance should be less than 100 Ω

Length of straight pipe**Upstream side**

A minimum of five straight pipe diameters

A minimum of 10 straight pipe diameters is required if diffuser/valve/pump installed on the upstream side.

Downstream side

Two straight pipe diameters are recommended.

Mounting

Integral style (installed on the piping)

Optional specification**Carbon steel bolts and nuts**

Carbon steel bolts and nuts for installing the detector on the piping are provided.

MODEL SELECTION

Electromagnetic calorimeter 25 to 100 mm wafer type (Integral style only)

Basic Model No.		Selections		Options	
MCM10A					
Size	25 mm	025		X	None
	40 mm	040		B	Traceability certificate
	50 mm	050		C	Carbon steel bolts and nuts
	65 mm	065		K	Setting customer's requested range
	80 mm	080			
	100 mm	100			
Power supply	24 V DC	G			
Centering jig (customer's piping)	Wafer JIS10K				11
	Wafer JIS20K				12
	Wafer ANSI150				21
	Wafer DIN PN10				41
	Wafer DIN PN16				42

DIMENSIONS

[Unit: mm]

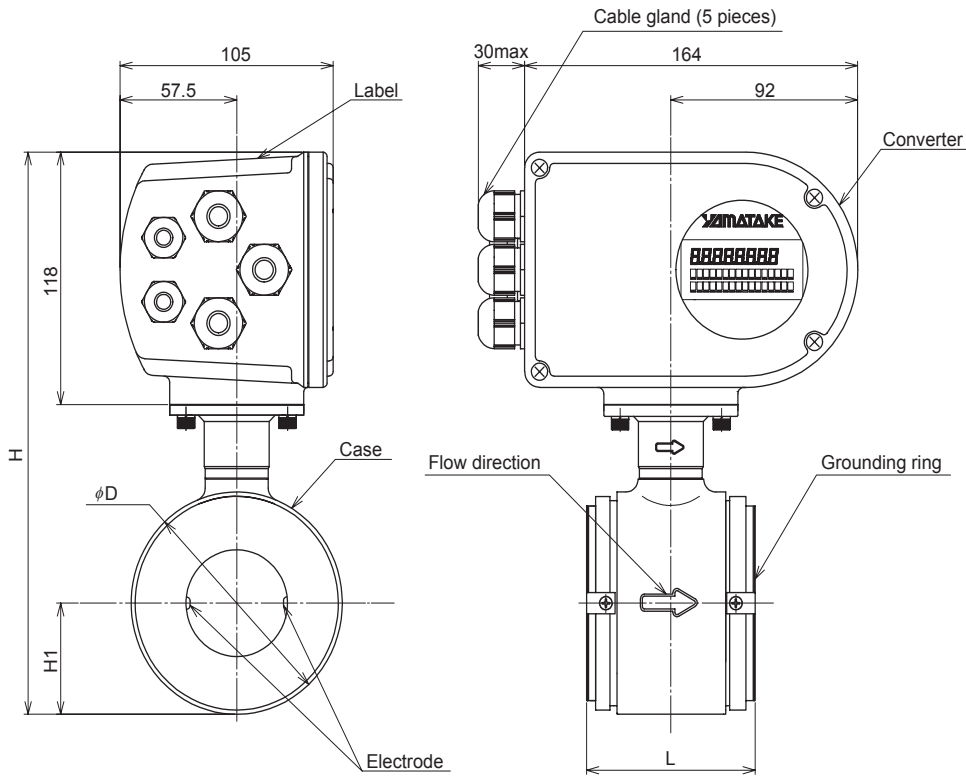

Nominal size (mm)		25	40	50	65	80	100
Face-to-face dimension (mm)	L	56	77	83	93	103	117
	H	229	245	263	280	293	318
Height (mm)	H1	34	43.5	52	62	67	79.5
	D	68	87	104	124	134	159



Savemation

Saving through Automation

Yamatake Corporation

Totate international Building
2-12-19 Shibuya
Shibuya-ku, Tokyo 150-8316
Japan
Tel : 81-3-3486-2310
Fax : 81-3-3486-2593



Certificate No. Q17862



Certificate No. E8318
For Shonan Factory