

Communication Controller CMC10G (PLC / Controller Converter) User's Manual



Thank you for purchasing the Communication Controller CMC10G.

This manual contains information ensuring correct use of the Communication Controller CMC10G. It also provides necessary information for installation and maintenance. To setup provide the AP editor which is sold as option. For further details on correct use, read the User's manual. (CP-UM-5146E)

RESTRICTIONS ON USE

When using this product in applications that require particular safety or when using this product in important facilities, pay attention to the safety of the overall system and equipment. For example, install fail-safe mechanisms, carry out redundancy checks and periodic inspections, and adopt other appropriate safety measures as required.

REQUEST

Make sure that this Instruction Manual is handed over to the user before the product is used.

Copying or duplicating this Instruction Manual in part or in whole is forbidden. The information and specifications in this Instruction Manual are subject to change without notice.

Considerable effort has been made to ensure that this Instruction Manual is free from inaccuracies and omissions.

If you should find any inaccuracies or omissions, please contact Yamatake Corporation.

In no event is Yamatake Corporation liable to anyone for any indirect, special or consequential damages as a result of using this product.

©2000 Yamatake Corporation ALL RIGHTS RESERVED

SAFETY PRECAUTIONS

Safety precautions are for ensuring safe and correct use of this product, and for preventing injury to the operator and other people or damage to property. You must observe these safety precautions. Also, be sure to read and understand the content of this user's manual.



WARNING

Warnings are indicated when mishandling this product might result in death or serious injury to the user.



CAUTION

Cautions are indicated when mishandling this product might result in minor injury to the user, or only physical damage to this product.

CAUTION

- Before wiring, removing or installing the CMC10L, be sure to turn the power OFF. Failure to do so might cause faulty operation.
- Do not disassemble the CMC10L. Doing so might cause faulty operation.
- Use the CMC10L within the operating ranges (temperature, humidity, voltage, vibration, shock, mounting direction, atmosphere, etc.) recommended in the specifications. Failure to do so might cause fire or faulty operation.
- Do not block ventilation holes. Doing so might cause fire or faulty operation.
- Wire the CMC10L properly according to predetermined standards. Also wire the CMC10L using designated power leads according to recognized installation methods. Failure to do so might cause electric shock, fire or faulty operation.
- Do not allow lead clippings, chips or water to enter the CMC10L case. Doing so might cause fire or faulty operation.
- Firmly tighten the terminal screws at the torque listed in the specifications. Insufficient tightening of terminal screws might cause fire.
- Do not use unused terminals on the CMC10L as relay terminals. Doing so might cause electric shock, fire or faulty operation.
- Use Yamatake Corporation's SurgeNon if there is the risk of power surges caused by lightning. Failure to do might cause fire or faulty operation.
- Do not throw used batteries into fire or discard them as general garbage. If you discard them at your site, follow regulations and rules stipulated by your local self-governing body.
- Do not short-circuit the batteries, and do not expose them to water as they may become hot or catch fire.
- If the battery is replaced, the clock data and trend data will be lost.
- When disposing of the CMC10L, dispose of it appropriately as industrial waste in accordance with local bylaws and regulations.

1. NAMES AND FUNCTIONS OF PARTS

Body

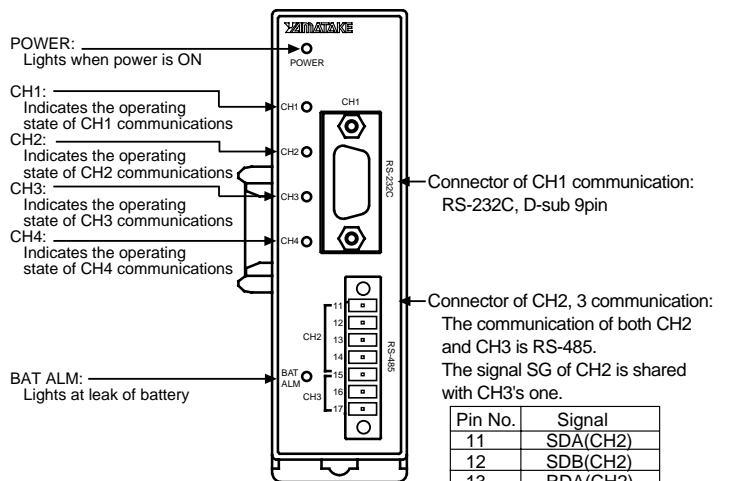

Pin No.	Signal
11	SDA(CH2)
12	SDB(CH2)
13	RDA(CH2)
14	RDB(CH2)
15	SG(CH2, 3)
16	DA(CH3)
17	DB(CH3)

■ Base

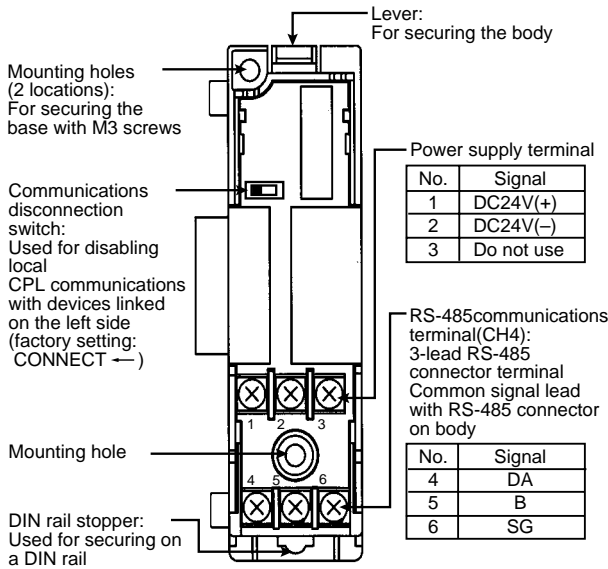

● When securing on a DIN rail

Secure the CMC10G on the DIN rail, fully draw out the DIN rail stopper and hook the base onto the DIN rail. Next, push the mounting lever upwards until you hear it click into place.

■ Mounting the body on the base

Please the hook into the base and push the body into the base until you hear it click into place.
To remove the body from the base, pull the body towards you while pressing down the lever.

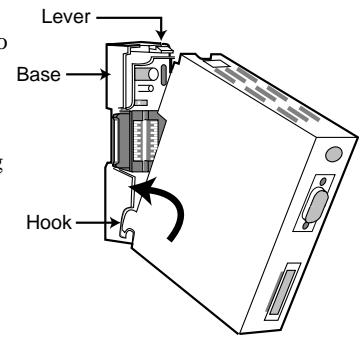

! Handling Precautions

Do not use unused terminals as relay terminals.

2.MOUNTING

■ Mounting Locations

Avoid installing the CMC10G in the following locations:

- Locations subject to low and high temperature and humidity
- Locations subject to corrosive gases such as sulfide gases
- Locations subject to dust or oil fume
- Locations subject to direct sunlight, wind or rain
- Locations subject to vibration or shock
- Locations under high-voltage lines and near sources of electrical noise such as welders
- Locations within 15 meters of high-voltage ignition equipment such as boilers
- Locations where magnetic fields are generated
- Locations near flammable liquid or steam

■ Linking modules

The CMC10G can be linked with other modules by the connectors on the left and right of the base. Modules must be linked before the CMC10G is mounted on the DIN rail or mounted by screws.
By linking modules together, the power supply of each module and RS-485 (CH4) communications are connected, eliminating the need for wiring.
RS-485 (CH4) communications can be disconnected by the communications disconnection switch located on the base.

■ Mounting method

The CMC10G can be mounted in either of two ways, by mounting its base by screws or by securing on a DIN rail.

● When mounting the base by screws

Secure the two mounting holes on the base by M3 screws.

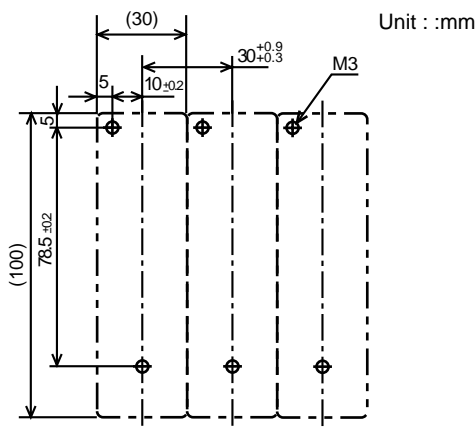

3.WIRING

■ Compensating Lead

- Use shielded polyethylene insulated vinyl sheathed cable for instrumentation for RS-485 input/output and power supply.
- Use shielded cable for RS-232C input/output.

■ Wiring precautions

Be sure to use crimped terminals for wiring terminals. When wiring is finished, check the connections for any miswiring before turning the power ON.

■ Connecting the power supply

Connect the 24Vdc power supply to terminals (1) and (2) on the base.

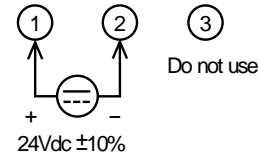

! Handling Precautions

- Power is mutually connected between linked modules. Supply power to one of the linked modules.
- Select a power supply that can cover the total power consumption of all linked modules.

■ Connecting for CH1 Communications(RS-232C)

Connect the cable to the D-SUB 9-pin connector on the CMC10G.

Pin No.	Signal	TERMINAL Contents
1 *1	CD	Unused
2	RD	Receive data (Peer device → CMC10G)
3	SD	Send data (CMC10G → Peer device)
4 *1	ER	Unused
5	SG	Signal ground
6 *1	DR	Unused
7 *2	RS	Unused
8 *2	CS	Unused
9	CI	Unused

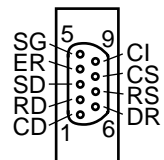

- *1 Pin Nos. 1, 4 and 6 are each connected internally.
- *2 Pin Nos. 7 and 8 are connected internally.

■ Connecting for CH2 Communications(RS-485)

This communication is performed a 5-leads connection of RS-485 and it's also performed a 3-leads. The connector for this interface is installed.

Connect the terminator (150Ω, 1/2W).

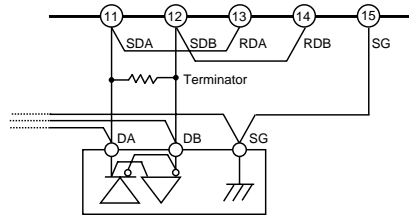

Fig:Example of connecting to 3-leads product

■ Connecting for CH3 Communications(RS-485)

This communication is performed a 3-leads connection of RS-485. The connector for this interface is installed. This is shared with CH2.

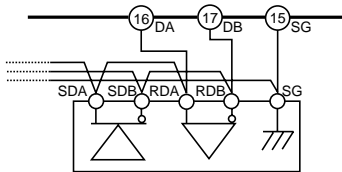

Fig:Example of connecting to 5-leads product

! Handling Precautions

Don't connect the terminator because of installing this function such as the terminator in the product.

■ Connecting for CH4 Communications(RS-485)

This communication is performed a 3-leads connection of RS-485. This interface is connecting to the terminal of base.

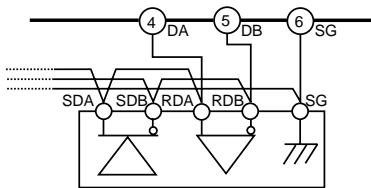

Fig:Example of connecting to 5-leads product

! Handling Precautions

Don't connect the terminator because of installing this function such as the terminator in the product.

4.SETUP

To setup, provide the AP editor which is sold as option, Model number : ESTX240SWWJC000.

It is also shared with another product, EST240Z. In this product, a part of this editor is just used.

Refer to the Smart Terminal EST240Z user's manual (CP-UM-5146E).

5. MAINTENANCE

■ Charge the battery

! CAUTION

- Do not throw used batteries into fire or discard them as general garbage. If you discard them at your site, follow regulations and rules stipulated by your local self-governing body.
- Do not short-circuit the batteries, and do not expose them to water as they may become hot or catch fire.
- If the battery is replaced, the clock data and trend data will be lost.

● Procedure

- (1) Take off the printed wiring board from case.
(Pull it while rising two hook at the case)
- (2) Release both printed wiring boards.
- (3) Remove the battery from the board.
- (4) Set the new battery.

! Handling Precautions

Pay attention to the polarity of battery.

- (5) Connect both printed wiring boards.
- (6) Set the boards to case.

📖 NOTE

Please change the battery within the date which is written at the side of case.

(YYYY: means year, MM: means month)

6.SPECIFICATIONS

■ Specifications

Item	Specifications		
Communica-tions	CH1	RS-232C Full duplex Max. 15m D-sub 9pin	
	CH2	RS-485 Full duplex 5-lead Max. 500m connector	
	CH3	RS-485 Half duplex 3-lead Max. 500m connector	
	CH4	RS-485 Half duplex Max. 500m Screw terminal	
General specifications	Rated power voltage	24Vdc	
	Operating power voltage	21.6 to 26.4Vdc	
	Power consumption	Max. 3W	
	Insulation resistance	Min. 20MΩ by 500Vdc megger (between case and 24Vdc power terminal)	
	Dielectric strength	500Vac for 1min. (between case and 24Vdc power terminal)	
	Isolation	Between communication and power is isolated. Each CH of communication isn't isolated.	
	Memory backup	Min. 4years at 25°C	
	Operating condition	Ambient Temp.: 0 to 50°C Ambient Humidity : 30 to 90%RH	
	Transport/storage conditions	Ambient Temp.: -20 to +70°C Ambient Humidity : 10 to 95%RH	
	Screw tightening torque	Power terminal and CH4 communication terminal : 0.8 to 1.0N•m	
	Mounting	DIN rail mount or screw mount	
	Mask/Case	Mask/Case materials	Mask:Polycarbonate, Case:Polycarbonate, Base:Polycarbonate
		Mask/Case color	Mask:Navy blue, Case:Light gray, Base:Light gray
Mass	Approx.200g		
Applicable standards	EN50081-2, EN61000-6-2		
Accessories	User's Manual (No.CP-UM-5185E) 1packet (This Manual)		
	CH2, CH3 Communication Conector 1piece		
Maintenance Parts	Battery Model No.:81446345-001		
Optional parts	RS-232C Cable Model No.:CBL232FFT02		

■ External Dimensions

Unit :mm

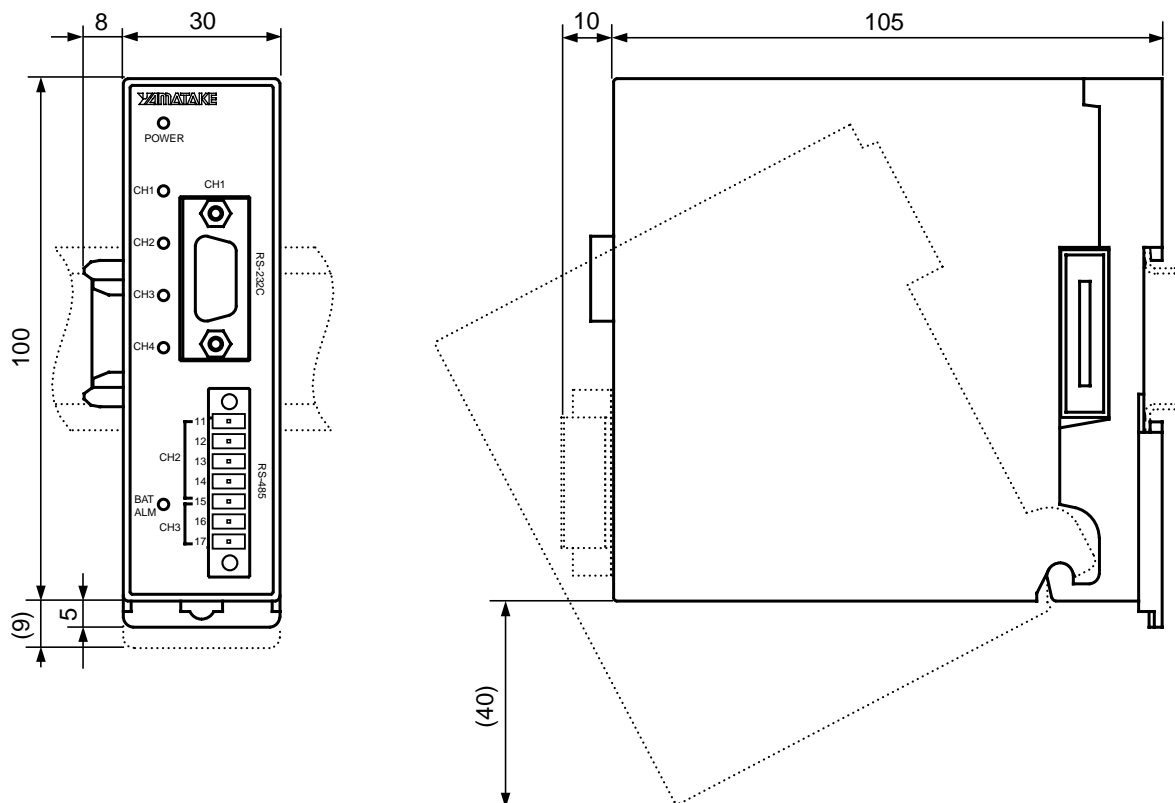

Specifications are subject to change without notice.

YAMATAKE

Yamatake Corporation

Control Product Division

Sales contact: Yamatake Corporation,
IBD Sensing and Control Department
Totate International Building

2-12-19 Shibuya Shibuya-ku Tokyo 150-8316 Japan

Phone: 81-3-3486-2380

Fax: 81-3-3486-2300

This has been printed on recycled paper.

Printed in Japan.

1st Edition: Issued in Sep.,2000(W)

3rd Edition: Issued in Mar., 2001(C)