

# Communication Controller CMC10B (CPL / CPL Converter) User's Manual

## SAFETY PRECAUTIONS

Safety precautions are for ensuring safe and correct use of this product, and for preventing injury to the operator and other people or damage to property. You must observe these safety precautions. Also, be sure to read and understand the content of this user's manual.



## WARNING

Warnings are indicated when mishandling this product might result in death or serious injury to the user.



## CAUTION

Cautions are indicated when mishandling this product might result in minor injury to the user, or only physical damage to this product.

Thank you for purchasing the Communication Controller CMC10B.

This manual contains information ensuring correct use of the Communication Controller CMC10B. It also provides necessary information for installation and maintenance.

This manual should be read by those who design and maintain devices that use the Communication Controller CMC10B. Be sure to keep this manual nearby for handy reference.

For further details on correct use, read the Communication Controller CMC10B (CPL/CPL converter) User's Manual (Design Manual) CP-SP-1064E.

## RESTRICTIONS ON USE

When using this product in applications that require particular safety or when using this product in important facilities, pay attention to the safety of the overall system and equipment. For example, install fail-safe mechanisms, carry out redundancy checks and periodic inspections, and adopt other appropriate safety measures as required.

## REQUEST

Make sure that this Instruction Manual is handed over to the user before the product is used.

Copying or duplicating this Instruction Manual in part or in whole is forbidden. The information and specifications in this Instruction Manual are subject to change without notice.

Considerable effort has been made to ensure that this Instruction Manual is free from inaccuracies and omissions.

If you should find any inaccuracies or omissions, please contact Yamatake Corporation.

In no event is Yamatake Corporation liable to anyone for any indirect, special or consequential damages as a result of using this product.

©2000 Yamatake Corporation ALL RIGHTS RESERVED



## CAUTION

- Before wiring, removing or installing the CMC10B, be sure to turn the power OFF. Failure to do so might cause faulty operation.
- Do not disassemble the CMC10B. Doing so might cause faulty operation.
- Use the CMC10B within the operating ranges (temperature, humidity, voltage, vibration, shock, mounting direction, atmosphere, etc.) recommended in the specifications. Failure to do so might cause fire or faulty operation.
- Do not block ventilation holes. Doing so might cause fire or faulty operation.
- Wire the CMC10B properly according to predetermined standards. Also wire the CMC10B using designated power leads according to recognized installation methods. Failure to do so might cause electric shock, fire or faulty operation.
- Do not allow lead clippings, chips or water to enter the CMC10B case. Doing so might cause fire or faulty operation.
- Firmly tighten the terminal screws at the torque listed in the specifications. Insufficient tightening of terminal screws might cause fire.
- Do not use unused terminals on the CMC10B as relay terminals. Doing so might cause electric shock, fire or faulty operation.
- Use Yamatake Corporation's SurgeNon if there is the risk of power surges caused by lightning. Failure to do might cause fire or faulty operation.
- When disposing of the CMC10B, dispose of it appropriately as industrial waste in accordance with bylaws and regulations.

# 1. NAMES AND FUNCTIONS OF PARTS

## Body

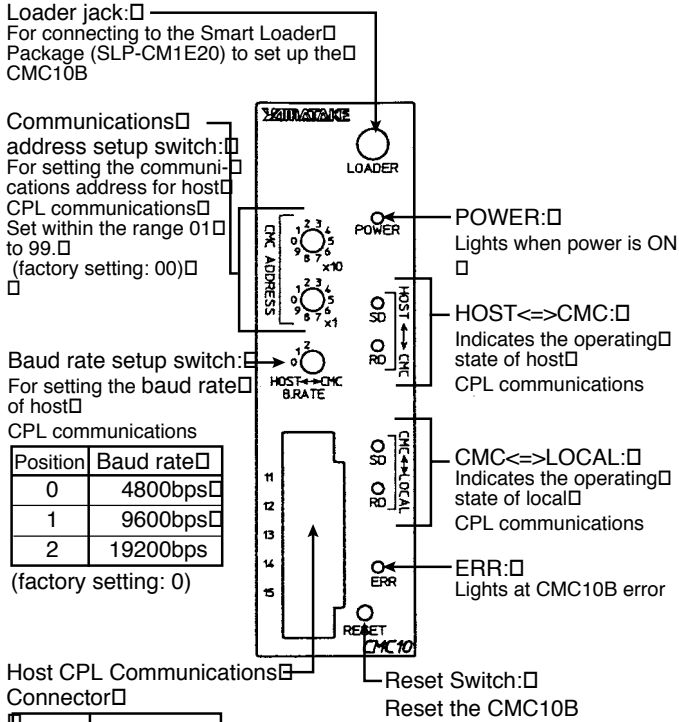

## Base

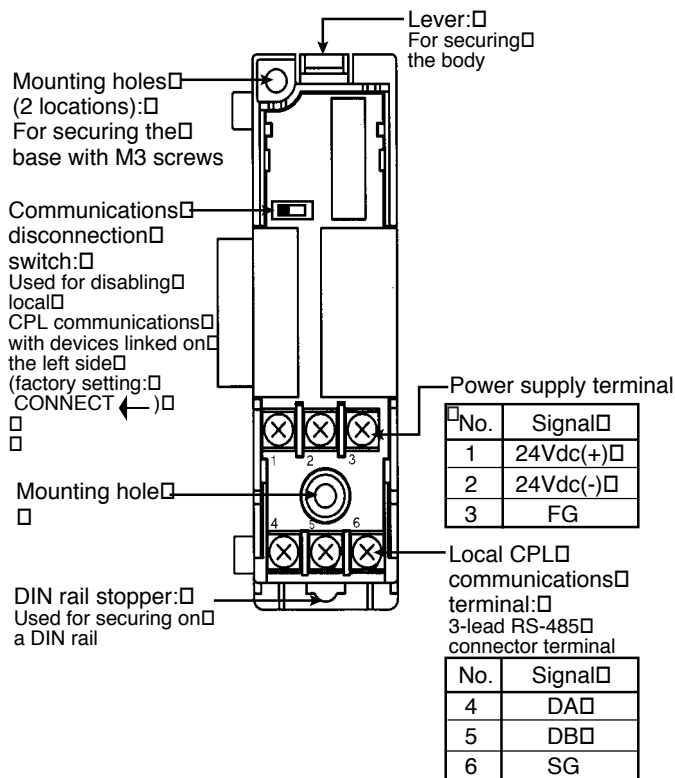

# 2. MOUNTING

## Mounting Locations

Avoid installing the CMC10B in the following locations:

- Locations subject to low and high temperature and humidity
- Locations subject to corrosive gases such as sulfide gases
- Locations subject to dust or oil fume
- Locations subject to direct sunlight, wind or rain
- Locations subject to vibration or shock
- Locations under high-voltage lines and near sources of electrical noise such as welders
- Locations within 15 meters of high-voltage ignition equipment such as boilers
- Locations where magnetic fields are generated
- Locations near flammable liquid or steam

## Linking modules

The CMC10B can be linked with other modules by the connectors on the left and right of the base. Modules must be linked before the CMC10B is mounted on the DIN rail or mounted by screws. By linking modules together, the power supply of each module and local CPL communications are connected, eliminating the need for wiring. Local CPL communications can be disconnected by the communications disconnection switch located on the base.

## Mounting method

The CMC10B can be mounted in either of two ways, by mounting its base by screws or by securing on a DIN rail.

### When mounting the base by screws

Secure the two mounting holes on the base by M3 screws.

Unit:mm

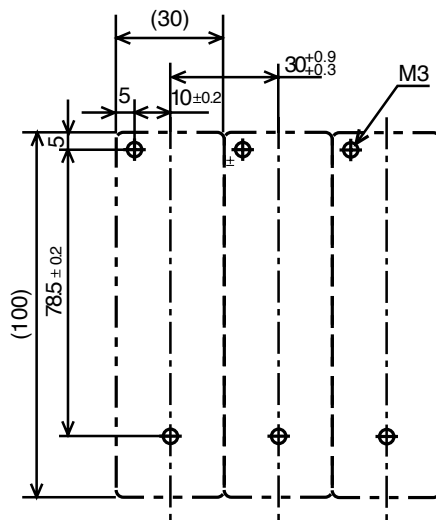

### When securing on a DIN rail

Secure the CMC10B on the DIN rail, fully draw out the DIN rail stopper and hook the base onto the DIN rail. Next, push the mounting lever upwards until you hear it click into place.

### ■ Mounting the body on the base

Please the hook into the base and push the body into the base until you hear it click into place.

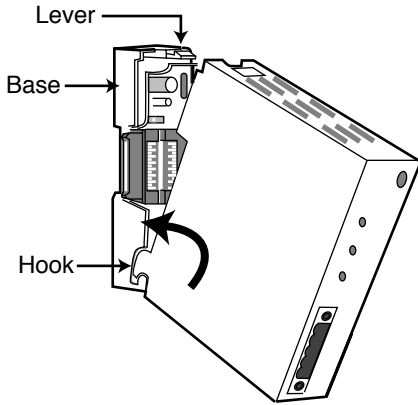

To remove the body from the base, pull the body towards you while pressing down the lever.

## 3.WIRING

### ■ Compensating Lead

Use shielded polyethylene insulated vinyl sheathed cable for instrumentation for inputs/outputs and power supply.

### ■ Wiring precautions

Be sure to use crimped terminals for wiring terminals. When wiring is finished, check the connections for any miswiring before turning the power ON.

### ■ Connecting the power supply

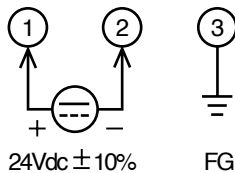

Connect the power terminal as follows:

### ! Handling Precautions

Power is mutually connected between linked modules.

Supply power to one of the linked modules.

Select a power supply that can cover the total power consumption of all linked modules.

### ■ Connecting local CPL communications (CMC<=>LOCAL)

Local CPL communications (RS-485) is performed using a 3-lead connection.

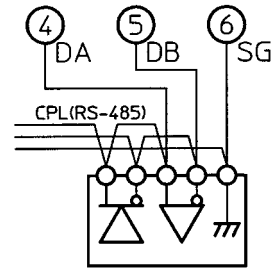

Ex: Connection with a 5-lead device

### ■ Connecting host CPL communications (HOST<=>CMC)

Host CPL communications is performed using a connector.

The applicable connector is 81440792-001 (set of 4) MSTB2,5/5-STF-5,08 AU made by Phoenix Contacts Ltd. or equivalent product.

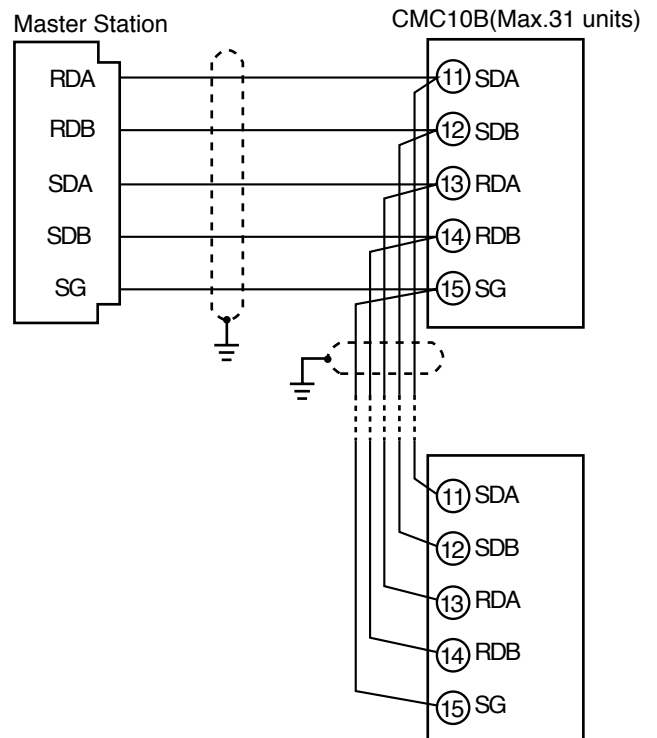

Ex: Connection with a 5-lead device

## 4.SETUP

Set up the CMC10B as follows before use:

- (1) Set the CMC10B communications address for host CPL communications.
- (2) Set the baud rate for host CPL communications.
- (3) Set the communications disconnection switch.
- (4) Make settings relating to the CPL communications mode configuration.

Make these settings via the loader jack.

For details, refer to the Communication Controller CMC10B (CPL/CPL converter) User's Manual (Design Manual) CP-SP-1064E.

## 5.SPECIFICATIONS

### ■ Specifications

Item	Specifications
Communications mode	HOST↔CMC communications CPL (RS-485 5-lead type)
	CMC↔Local communications CPL (RS-485 3-lead type)
	CMC↔PC communications CPL (cable provided with Smart Loader Package)
Operating conditions	Ambient temperature 0 to 50°C
	Ambient humidity 30 to 90%RH
	Power voltage 24Vdc ± 10%
Transport/storage conditions	Ambient temperature -20 to +70°C
	Ambient humidity 10 to 95%RH
	Vibration resistance Max.4.9m/s <sup>2</sup> (10 to 60 Hz, for 2h each in X, Y and Z directions)
	Impact resistance Screw mount: max. 392m/s <sup>2</sup> DIN rail mount: max. 196m/s <sup>2</sup>
	Package drop test Drop height 60cm (1 corner, 3 sides, 6 planes, free fall)
Other	Insulation resistance Min. 50Ω (by 500Vdc megger)
	Dielectric strength 500Vac for 1min
	Mass Approx.300g
	Mounting Screw mount or DIN rail mount
	Screw tightening torque •Power terminal,CPL communications terminal 0.8 to 1N•m •Connector terminal for host CPL communication connection 0.8N•m •Connector mount for host CPL communication connection 0.8N•m
	Power voltage 24Vdc ± 10%
	Power consumption 5W
	Applicable standards EN50081-2, EN50082-2
	Sold separately Smart Loader Package SLP-CM1E20

### ■ External Dimensions

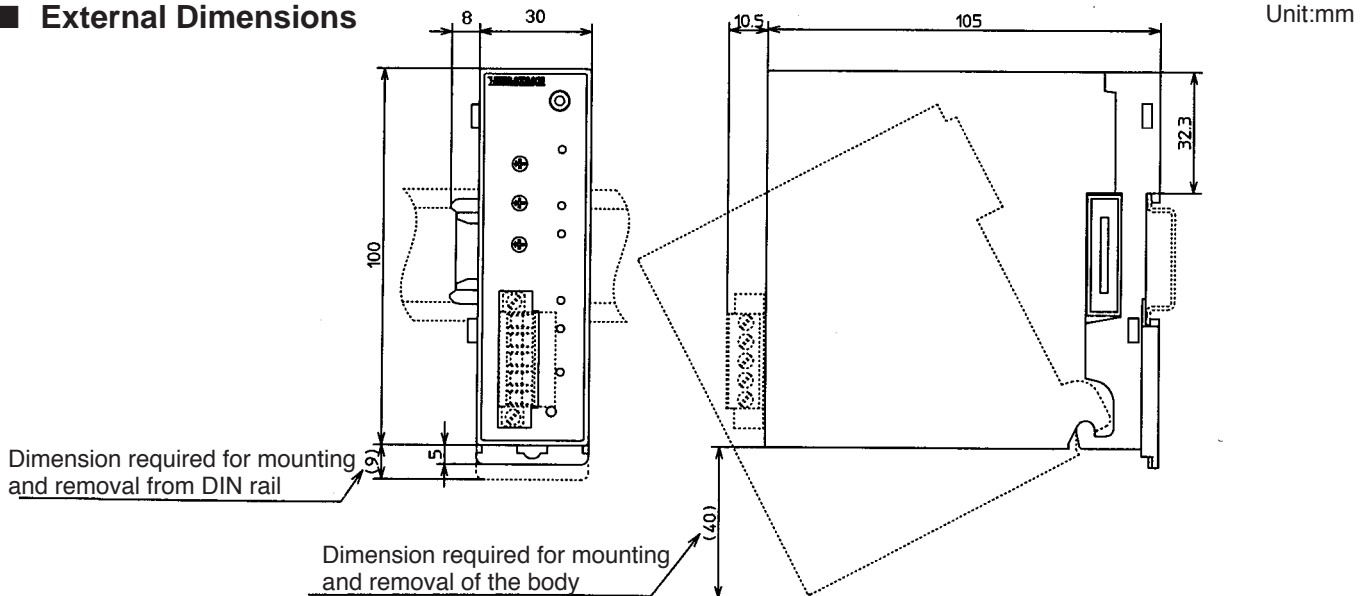

Specifications are subject to change without notice.

**YAMATAKE**

### Yamatake Corporation

#### Control Products Division

Head office : Totate International Building  
2-12-19 Shibuya Shibuya-ku Tokyo 150-8316 Japan

**Inquiries to :** International Business Division

Phone : 81-3-3486-2331, Fax : 81-3-3486-2300 (Sales)

Phone : 81-466-20-2307, Fax : 81-466-27-9264 (Customer Service)

<http://www.yamatake.com>

This has been printed on recycled paper.

Printed in Japan.

1st Edition: Issued in July, 2000(W)

3rd Edition: Issued in July, 2002(W)