

Communication Controller CMC10P (PROFIBUS-DP/CPL Converter)

User's Manual Design Manual

Thank you for purchasing the CMC10P. This manual contains information for ensuring correct use of the CMC10P. It also provides necessary information for installation, maintenance, and troubleshooting.

This manual should be read by those who design and maintain devices that use the CMC10P.

Be sure to keep this manual nearby for handy reference.

Yamatake Corporation

RESTRICTIONS ON USE

When using this product in applications that require particular safety or when using this product in important facilities, pay attention to the safety of the overall system and equipment. For example, install fail-safe mechanisms, carry out redundancy checks and periodic inspections, and adopt other appropriate safety measures as required.

REQUEST

Ensure that this User's Manual is handed over to the user before the product is used.

Copying or duplicating this User's Manual in part or in whole is forbidden. The information and specifications in this User's Manual are subject to change without notice.

Considerable effort has been made to ensure that this User's Manual is free from inaccuracies and omissions.

If you should find any inaccuracies or omissions, please contact Yamatake Corporation.

In no event is Yamatake Corporation liable to anyone for any indirect, special or consequential damages as a result of using this product.

©2002 Yamatake Corporation ALL RIGHTS RESERVED

Windows® and Microsoft® Excel are registered trademarks of Microsoft Corporation USA and other countries.

Other company names and product names listed in this manual are registered trademarks or trademarks of respective companies.

SAFETY PRECAUTIONS

■ About Icons

Safety precautions are for ensuring safe and correct use of this product, and for preventing injury to the operator and other people or damage to property. You must observe these safety precautions. The safety precautions described in this manual are indicated by various icons.

As the following describes the icons and their meanings, be sure to read and understand the descriptions before reading this manual:



WARNING

Warnings are indicated when mishandling this product might result in death or serious injury to the user.













CAUTION

Cautions are indicated when mishandling this product might result in minor injury to the user, or only physical damage to this product.

■ Examples

	<p>Triangles warn the user of a possible danger that may be caused by wrongful operation or misuse of this product.</p> <p>These icons graphically represent the actual danger. (The example on the left warns the user of the danger of electrical shock.)</p>
	<p>White circles with a diagonal bar notify the user that specific actions are prohibited to prevent possible danger.</p> <p>These icons graphically represent the actual prohibited action. (The example on the left notifies the user that disassembly is prohibited.)</p>
	<p>Black filled-in circles instruct the user to carry out a specific obligatory action to prevent possible danger.</p> <p>These icons graphically represent the actual action to be carried out. (The example on the left instructs the user to remove the plug from the outlet.)</p>

CAUTION

	<p>Before wiring, removing or installing the CMC10P, be sure to turn the power OFF. Failure to do so might cause faulty operation.</p>
	<p>Do not disassemble the CMC10P. Doing so might cause faulty operation.</p>
	<p>Use the CMC10P within the operating ranges (temperature, humidity, voltage, vibration, shock, mounting direction, atmosphere, etc.) recommended in the specifications. Failure to do so might cause fire or faulty operation.</p>
	<p>Do not block ventilation holes. Doing so might cause fire or faulty operation.</p>
	<p>Wire the CMC10P properly according to predetermined standards. Also wire the CMC10P using designated power leads according to recognized installation methods. Failure to do so might cause electric shock, fire or faulty operation.</p>
	<p>Do not allow lead clippings, chips or water to enter the CMC10P case. Doing so might cause fire or faulty operation.</p>
	<p>Firmly tighten the terminal screws at the torque listed in the specifications. Insufficient tightening of terminal screws might cause fire.</p>
	<p>Do not use unused terminals on the CMC10P as relay terminals. Doing so might cause electric shock, fire or faulty operation.</p>
	<p>Use Yamatake Corporation's SurgeNon if there is the risk of power surges caused by lightning. Failure to do so might cause fire or faulty operation.</p>
	<p>When disposing of the CMC10P, dispose of it appropriately as industrial waste in accordance regulations.</p>

The Role of This Manual

In all, two manuals have been prepared for the CMC10P. Read the manual according to your specific requirements. The below lists all the manuals that accompany the CMC10P and gives a brief outline of the manual. If you do not have the required manual, contact Yamatake Corporation or your dealer.

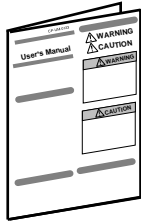

Communication Controller CMC10P (PROFIBUS-DP/CPL Converter) Manual No.CP-UM-5243E

This manual is packaged with the CMC10P.

It describes only precautions and how to handle the CMC10P. Be sure to read this manual when installing and wiring the CMC10P.

For further details on how to handle the CMC10P, read the Communication Controller CMC10P (PROFIBUS-DP/CPL Converter) Design Manual No. CP-SP-1126E.

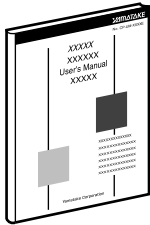

Communication Controller CMC10P (PROFIBUS-DP/CPL Converter) User's Manual (Design Manual)

Manual No.CP-SP-1126E

This manual.

This manual should be read by for those who use the CMC10P, those who design hardware for integrating the CMC10P into operator control panels, those who carry out maintenance, and those who operate instruments in which the CMC10P is integrated.

It describes an outline of the CMC10P, how to install and wire for integrating the CMC10P into other devices, communications functions, troubleshooting and specifications.

Organization of This User's Manual

This manual is organized as follows:

Chapter 1. INTRODUCTION

This chapter describes an outline of the CMC10P, its features and a system configuration.

Chapter 2. NAMES & FUNCTIONS OF PARTS

This chapter describes the names and functions of parts on the CMC10P.

Chapter 3. INSTALLATION & SETUP

This chapter describes installation sites for the CMC10P and how to install the CMC10P.

Chapter 4. WIRING

This chapter describes the connecting procedures of the power to the CMC10P, the CPL communications and the PROFIBUS-DP communications.

Chapter 5. HOW TO USE THE CMC10P

This chapter describes the setup and basic method of use when using the CMC10P for the first time, and the cautions for programming.

Chapter 6. TROUBLESHOOTING

This chapter describes how to remedy trouble that might occur.

Chapter 7. SPECIFICATIONS

This chapter describes the specifications and external dimensions of the CMC10P.

Contents

SAFETY PRECAUTIONS

The Role of This Manual

Organization of This User's Manual

Conventions Used in This Manual

Chapter 1. INTRODUCTION

- Outline 1-1
- Configuration and Features 1-1

Chapter 2. NAMES & FUNCTIONS OF PARTS

- Body 2-1
- Base 2-1
- LED Indications 2-2

Chapter 3. INSTALLATION & SETUP

- Mounting Locations 3-1
- Linking Modules 3-1
- Installation Procedure 3-2

Chapter 4. WIRING

- Cables Used 4-1
- Wiring Precautions 4-2
- Connecting the Power Supply 4-2
- Connecting Local CPL Communications 4-3
- Connecting host communications (PROFIBUS<=>CMC) 4-3

Chapter 5. HOW TO USE THE CMC10P

- 5-1 Using the CMC10P for the First Time 5-1
 - Setting Up the Host 5-1
 - Setting Up the Hardware 5-2
 - Setting Up the Parameter 5-3
 - Setting Up the Local Device 5-7
 - Setting Up the Terminal and Sample Operation 5-7
- 5-2 Linking with the Host 5-15
 - Overview of the Link Area Mapping 5-15
- 5-3 Sample Ladder 5-16
 - Sample System Configuration 5-16
 - Setting Up the CMC10P 5-16
 - Sample Ladder Diagram 5-16

Chapter 6. TROUBLESHOOTING

- Errors on CMC10P 6-1
- PROFIBUS Communications Errors 6-1
- CPL Communications Errors 6-1

Chapter 7. SPECIFICATIONS

- **Communications Specifications** 7-1
- **General Specifications** 7-2
- **External Dimensions** 7-3

APPENDIX

- **Input/Output Mapping** APPENDIX-1
- **LED Indications** APPENDIX-5
- **Parameter File Format (Text Format)** APPENDIX-6
- **Parameter Sheet** APPENDIX-8
- **Communications Tests** APPENDIX-11

Index

Conventions Used in This Manual

The following conventions are used in this manual:

 **Handling Precautions**

: Handling Precautions indicate items that the user should pay attention to when handling the **CMC10P**.

 **Note**

: Notes indicate useful information that the user might benefit by knowing.

(1), (2), (3)

: The numbers with the parenthesis indicate steps in a sequence or indicate corresponding parts in an explanation.

[Open] button

: Indicates a selection button in screens displayed on the personal computer.

[File], [Monitor], [Save] : Indicates messages and menus displayed on the personal computer.

[cmc_-u]

: An “_” indicates a space.

Chapter 1. INTRODUCTION

■ Outline

The CMC10P controller is for connecting a PROFIBUS-DP (Hereafter, what was only indicated to be PROFIBUS means PROFIBUS-DP.) master to local devices such as controllers that support CPL communications*.

The CMC10P samples the data of the local devices at all times, and ensures trouble-free data communications between the local devices and the master.

* CPL(Controller Peripheral Link) communications network is the Yamatake Corporation's host-communications.

■ Configuration and Features

- Up to 16 CPL communications-compatible local devices can be connected to each CMC10P.

However, it is to the number equivalent to 8 / 16 segment *.

- Communications performance when multiple devices are connected can be improved as the CMC10P samples set data at all times.
- The CMC10P can be linked with the modular controller DMC10 via the RS-485 connector on the side of the body, eliminating the need for wiring.
- The CMC10P can be mounted either on DIN rail or by screws.
- Small and lightweight, the CMC10P helps save space.
- A setup of CMC10P of operation can be set up by general-purpose communicating software (TTY procedure).
- The CMC10P conforms to IEC directives, and has acquired CE marking. (applicable standard: EN50081-2, EN50082-2)

When the CE standard is to be acquired on the instrumentation, use a third-party 24Vdc power supply that has CE marking.

* One segment is equivalent to the data for 8 words at the time of 8 segments setup and it is equivalent to the data for 4 words at the time of 16 segments setup.

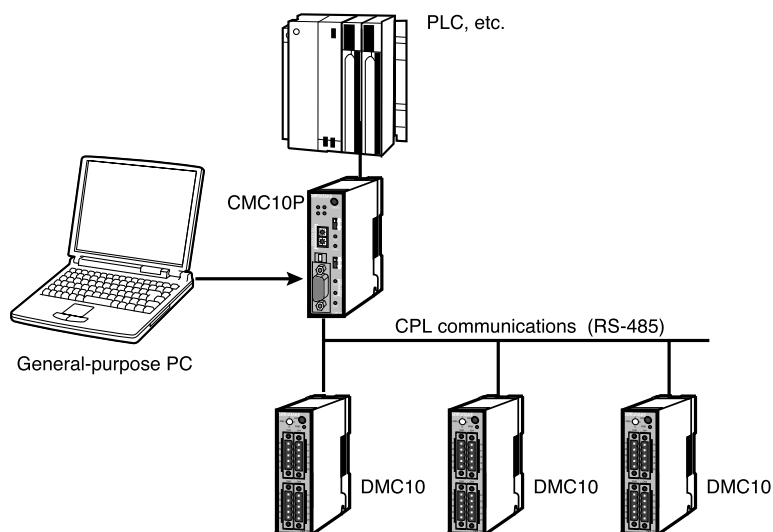

The number of local devices differs when a DMC10 unit is connected.

Chapter 2. NAMES & FUNCTIONS OF PARTS

■ Body

● Front

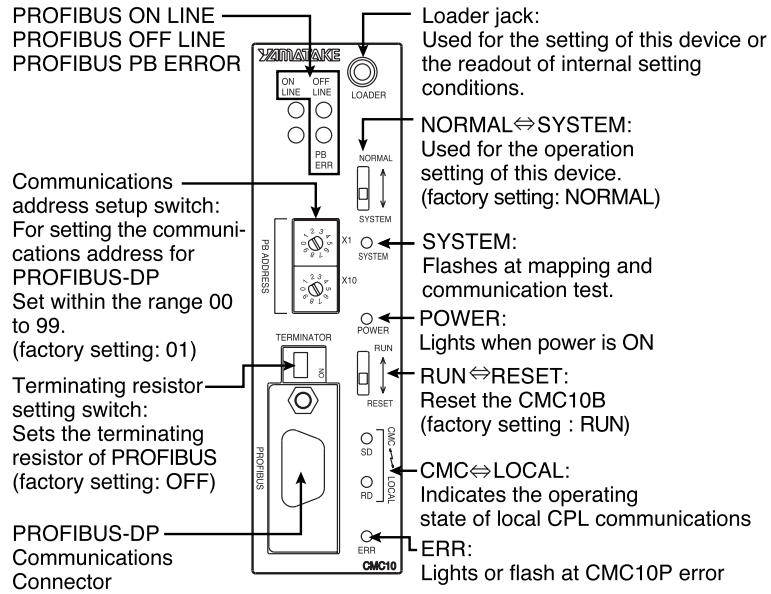

● Rear

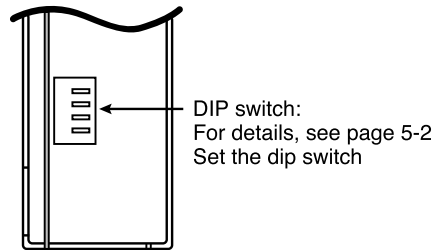

■ Base

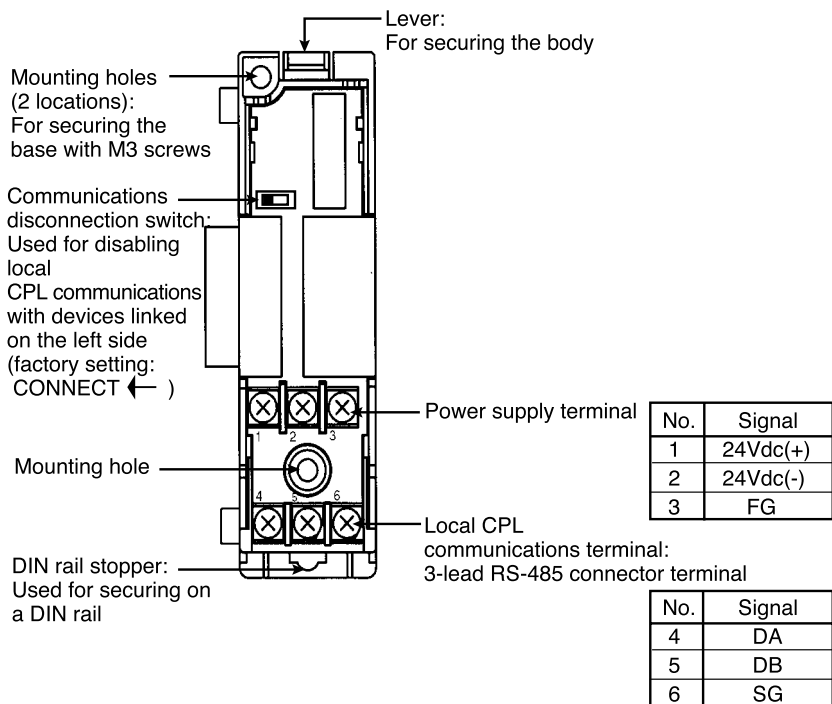

■ LED Indications

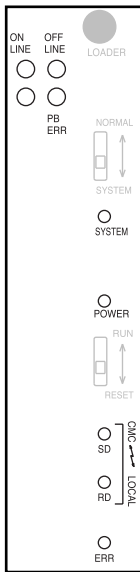

Name	Color	Functions outline
ON LINE	Green	Lights when PROFIBUS On Line
OFF LINE	Red	Lights when PROFIBUS Off Line
PB ERR	Red	Lights when PROFIBUS error occurred
SYSTEM	Yellow	Lights when the module is system or test mode
POWER	Green	Lights when the power is ON
SD	Green	Lights during transmission of communications data on local station
RD	Green	Lights during reception of communications data on local station
ERR	Red	Lights at a device error

Refer to the appendix for the details of the function of LEDs.

Chapter 3. INSTALLATION & SETUP

CAUTION



Before wiring, removing or installing the CMC10P, be sure to turn the power OFF.

Failure to do so might cause faulty operation.



Do not disassemble the CMC10P.

Doing so might cause faulty operation.



Use the CMC10P within the operating ranges (temperature, humidity, voltage, vibration, shock, mounting direction, atmosphere, etc.) recommended in the specifications.

Failure to do so might cause fire or faulty operation.



Do not block ventilation holes.

Doing so might cause fire or faulty operation.



Do not allow lead clippings, chips or water to enter the CMC10P case.

Doing so might cause fire or faulty operation.

■ Mounting Locations

Avoid installing the CMC10P in the following locations:

- Locations subject to low and high temperature and humidity
- Locations subject to corrosive gases such as sulfide gases
- Locations subject to dust or oil smoke
- Locations subject to direct sunlight, wind or rain
- Locations subject to vibration or shock
- Locations under high-voltage lines and near sources of electrical noise such as welders
- Locations within 15 meters of high-voltage ignition equipment such as boilers
- Locations where magnetic fields are generated
- Locations near flammable liquid or steam

■ Linking Modules

The CMC10P can be linked with other modules by the connectors located to the left and right of its base.

Modules must be linked before the CMC10P is mounted on the DIN rail or mounted by screws.

When modules are linked, the following signal leads and power leads are connected:

- Local station communications
- 24Vdc power lead
- Event lead (not used on the CMC10P)

When linked with a DMC10 unit, place the CMC10P at the left end.

The number of modules that can be linked is limited by the following formula:

$$100W \geq \text{Total power consumption of linked modules}$$

Local station communications can be disconnected by the communications disconnection switch located on the base of the CMC10P.

■ Installation Procedure

The CMC10P can be mounted in either of two ways, by mounting its base by screws or by securing on a DIN rail.

● When mounting the base by screws

(1) Mounting the base by screws

Secure the two mounting holes on the base by M3 screws.

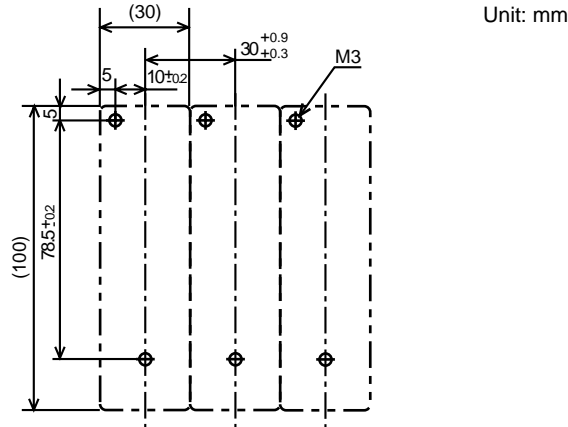

(2) Mounting the body on the base

Fit the hook into the base and push the body into the base until you hear it click into place.

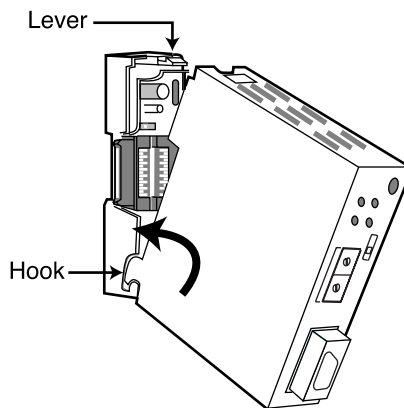

To remove the body from the base, pull the body towards you while pressing down on the lever.



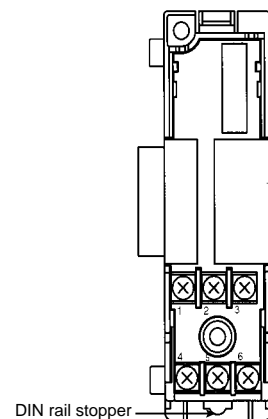

● When securing on a DIN rail

Secure the CMC10P on the DIN rail, fully draw out the DIN rail stopper and hook the base onto the DIN rail. Next, push the mounting lever upwards until you hear it click into place.



Chapter 4. WIRING

CAUTION

-  Before wiring, removing or installing the CMC10P, be sure to turn the power OFF.
Failure to do so might cause faulty operation.
-  Wire the CMC10P properly according to predetermined standards.
Also wire the CMC10P using designated power leads according to recognized installation methods.
Failure to do so might cause electric shock, fire or faulty operation.
-  Firmly tighten the terminal screws at the torque listed in the specifications.
Insufficient tightening of terminal screws might cause fire.
-  Do not use unused terminals on the CMC10P as relay terminals.
Doing so might cause electric shock, fire or faulty operation.
-  Use Yamatake Corporation's SurgeNon if there is the risk of power surges caused by lightning.
Failure to do so might cause fire or faulty operation.

■ Cables Used

- Use shielded polyethylene insulated vinyl sheathed cable JCS-364 for instrumentation for CPL communication/powerline.
(Normally, this is referred to as twisted cable for instrumentation.)
- When there is comparatively little electromagnetic conduction, shielded multi-core microphone cord (MVVS) can be used.
- For PROFIBUS communications, use cables certified by the PROFIBUS Nutzerorganisation e.V. For the connector for PROFIBUS, use a straight type.
For the recommended connectors, see “● Communications Specifications” in Chapter 7 “SPECIFICATIONS”.

Recommended Twisted Cable Leads

Fujikura	2-lead	IPEV-S — 0.9mm ² x 1P
Ltd	3-lead	ITEV-S — 0.9mm ² x 1T

■ Wiring Precautions

- Be sure to use crimped terminals for wiring terminals.
Use round terminals to prevent the crimped terminals from coming loose from the terminal on the CMC10P.
Use insulated covered crimped terminals.
Prevent crimped terminals from coming into contact with adjacent terminals.
- Check the terminal numbers before wiring.
- When wiring is finished, check the connections for any miswiring before turning the power ON.
- Ground the CMC10P at one point only (FG terminal). Do not ground the CMC10P using two or more terminals.
- When there are many shielded leads to ground, prepare a separate ground terminal plate (earth bar):
Ground type :GND (min. 100Ω)
Ground lead :Annealed conductive lead of 2mm² or more (AWG14)
Ground lead length :Max. 20m
- For the PROFIBUS communications, also see “Installation Guideline for PROFIBUS-DP/FMS” issued by PROFIBUS Nutzerorganisation e.V.

Note

URL for downloading the Installation Guideline:

<http://www.profibus.com/profibus.html>

■ Connecting the Power Supply

Connect the power terminal as follows:

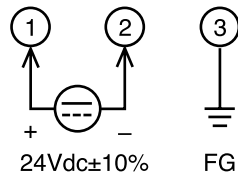

Handling Precautions

- Power is mutually connected between linked modules.
- Supply power to one of the linked modules.
- Select a power supply that can cover the total power consumption of all linked modules.

■ Connecting Local CPL Communications

Local CPL communications (RS-485) is performed using a 3-lead connection.

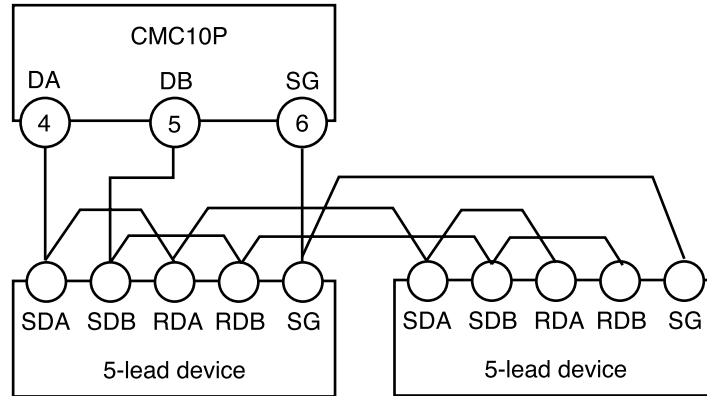

Example of connection with a 5-lead device

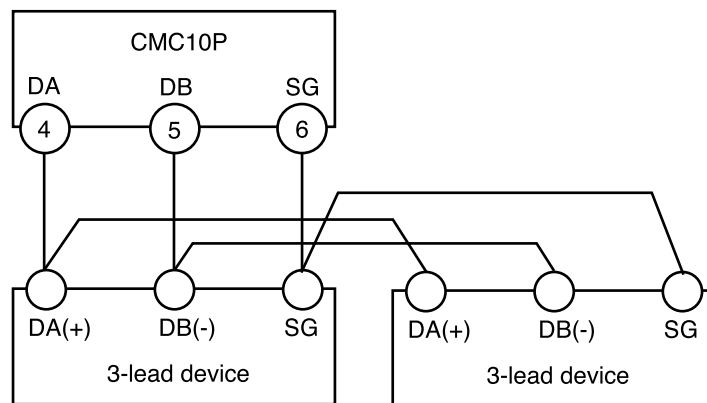

Example of connection with a 3-lead device

■ Connecting host communications (PROFIBUS<=>CMC)

Host communications is performed using a connector.

The applicable connector is 6GK1500-0FC00, 6GK1500-0EA02 made by SIEMENS AG. or equivalent product.

! Handling Precautions

Terminating resistor can be set also at connector side if recommended connector is used. In this case, the resistor of this device must be set to OFF.

Chapter 5. HOW TO USE THE CMC10P

5 - 1 Using the CMC10P for the First Time

To use the CMC10P, it is necessary to set up:

- (1) the host,
- (2) the CMC10P hardware,
- (3) the CMC10P parameter, and
- (4) the local device.

The following part of this section describes these setup procedures:

■ Setting Up the Host

When setting up the CMC10P with the PROFIBUS-DP, it is necessary to set up it as a device occupying 70 words on both input and output sides respectively.

You can download the GSD file from the URL of the PROFIBUS International shown below:

<http://www.profibus.com/libraries.html>

Company : Yamatake Corporation
Device Type : General
Devices : Communication Controller CMC10P
GSD File name : yc_0693.gsd

The sample setting is that for the PLC S7-300 made by Siemens AG.

The screenshot shows the SIMATIC Manager HW Config interface. The main window displays a rack configuration for a SIMATIC 300 station. The rack contains a PS 307 5A power supply, a CPU 315-2 DP Master, and a CMC10P DP-NORM module. The CMC10P module is connected to a PROFIBUS DP master system (1). The right-hand pane shows the device tree for the CMC10P, including I/O, General, and CMC10P specific parameters. The bottom pane shows a table of module parameters.

Sl.	Module / DP...	Order number	I Address	Q Address	Comment
1	192	IN/OUT: 128 Byte	256..383	256..383	
2	115	IN/OUT: 8 Byte	384..391	384..391	
3	113	IN/OUT: 4 Byte	392..395	392..395	
4					
5					
6					

■ Setting Up the Hardware

Make the setting for the PROFIBUS station address and the dip switches on the equipment.

● Set the station address

The station address is set with the rotary switch with the indication of “PB ADDRESS” on the CMC10P.
 The station address can be set in the range from 00 to 99.
 “X10” and “X1” stand for the ten place and the one place respectively.
 The factory setting is 01.

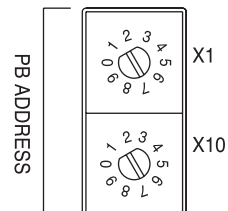

! Handling Precautions

The new settings become effective after the CMC10P is powered off and on or rebooted with the RESET switch. If you changed the settings, make sure to turn off and on the power or reset the CMC10P by setting the RUN/RESET switch to “RUN”, “RESET”, then “RUN” in this order.

● Set the dip switches

Available in SYSTEM mode.

1	2	3	4	Function
OFF	OFF	OFF	OFF	Automatic mapping (16 segments)
ON	OFF	OFF	ON	Automatic mapping (8 segments)
OFF	OFF	OFF	ON	Host communication test
ON	OFF	OFF	ON	Local communication test
ON	ON	ON	ON	Reserved

Settings other than the above are unused.

However, if the setting other than the above is made in SYSTEM mode, Local communication test is applied.

! Handling Precautions

Do not set all the dip switches to ON position.

● Set the communications disconnect switch

Make sure to set to CONNECT position.

■ Setting Up the Parameter

Connect the terminal with the CMC10P and set the parameter.

When the host accesses to a local controller via the CMC10P, handle the host with data on a segment basis. Consequently, it is necessary to perform the assignment of the local device on a segment basis.

This section describes the parameter setup procedures.

● Preparations for parameter setup

● Connecting with the terminal

- Items to be prepared
- A terminal ready for TTY input/output (such as a PC)
 - A special cable 81440793-001

Connect the terminal with the loader jack of the CMC10P via the special cable.



Make the communication settings of the PC, etc as follows:

Item	Setting	Item	Setting
Transmission speed	19200 bps	Flow control	None
Data length	8 bits	Emulation	VT100
Parity	Even	LF	CR
Stop bit	1		

● Available commands

The following commands are available for the CMC10P in the TTY protocol:

Format	cmc [parameter]
Parameter	-d :download mapping table
	-u :upload mapping table
	-a :system information
	-l :cpl link list
	-i in_addr :profibus in mapped information (in_addr=0-63)
	-o out_addr :profibus out mapped information (out_addr=0-63)
	-r dp_addr len :cmc dparam read (dp_addr=0-7FFh, len=1-200h)
	-w dp_addr data :cmc dparam write (dp_addr=0-1FEh, 16bit data=0-ffffh)

! Handling Precautions

- If you changed the segment mapping, the new settings become effective after the CMC10P is powered off and on or rebooted with the RESET switch.
- The CMC10P supports two mapping types such as 8 segments and 16 segments. Other segment settings are invalid. Furthermore, it is not allowed to set two or more number of device addresses within one and the same segment number.
- The data address which can be set has been specified for each device. For details, see the manual of each device.
- If writing is performed to an EEPROM address, the writing count has a limit. Confirm the limit in the user's manual of the local device.

● **Setting procedures**

The setting item is the parameter of the segment mapping.

There are three types of setting methods as follows:

- 1 Use the automatic mapping
- 2 Perform the automatic mapping first, then upload the parameter, edit only the part to be changed, and download again
- 3 Create the parameter file first, then download it to the CMC10P

If you use a PC as a terminal, launch an application program of terminal emulator ready for VT100 mode and make settings.

The keys available on the terminal are as follows:

to , to , , : Character entry

(or) : Line feed

: Deletion of one character

! Handling Precautions

The following operations are unavailable: Command line editing using and , history editing using + , + , etc.

The following part describes the three types of parameter setting methods:

● **Method to “use the automatic mapping”**

- (1) Set the device address for the DMC10 avoiding overlaps (in the range from 1 to 31).
- (2) Set the dip switch on the rear of the CMC10P for 8 or 16 segments.
- (3) Power on the DMC10 and CMC10P, then make the communication settings of the DMC10.
- (4) Set the [NORMAL/SYSTEM] selector switch on the front panel to [SYSTEM].
- (5) Reset or power off and on the CMC10P.
- (6) The [SYSTEM] LED is flashing and [POWER] LED stay on.
- (7) The mapping operation will complete in about 40 seconds. Then the [SYSTEM] and [POWER] LED will stay on.
- (8) Set the [NORMAL/SYSTEM] selector switch to [NORMAL] and reset again.

! Handling Precautions

- When you use the automatic mapping, make the communication settings of the local device in advance. For communication settings, see “**■ Setting Up the Local Device**” on page 5-7.
- The target device addresses of automatic mapping are 1 through 31. The order of mapping is from 1 to 31. The searches are made as many as the segments in increasing order of address. Consequently, the devices exceeding the segment count are not mapped. See the following example.

[Example]

- 16-segment mapping
- Connect DMC10 4-channel models to the device addresses 1 through 3; connect DMC10 2-channel models to the device addresses 4 through 6. Since one channel corresponds to one segment, addresses 1 through 5 correspond to 16 segments as indicated by the following calculation:
 $3 \times 4 \text{ channels} + 2 \times 2 \text{ channels} = 16 \text{ channels} (= 16 \text{ segments.})$
 Consequently, the DMC10 units at the addresses 1 through 5 are mapped. However, the DMC10 at the address 6 is not mapped.

The factory settings of the DMC10 are as follows:

If it is used with other device(s) together, unify the settings.

Transmission speed :19200 bps

Data length :8 bits

Parity :Even

Stop bit :1

The defaults of this mapping shown below are common to every segment. Only the input area is mapped; the output area is not mapped.

In case of 8-segment mapping (8 words)

No.	IN area	OUT area
1	PV value	-
2	SP value in use	-
3	Event output/control output state	-
4	RUN/READY mode	-
5	All alarms representative	-
6	Control output value (during regular control)	-
7	-	-
8	-	-

- : Undefined

In case of 16-segment mapping (4 words)

No.	IN area	OUT area
1	PV value	-
2	SP value in use	-
3	Event output/control output state	-
4	RUN/READY mode	-

- : Undefined

- **Method to “perform the automatic mapping first, then upload the parameter, edit only the part to be changed, and download again”**

- (1) Perform automatic mapping.
- (2) Then upload the mapping data from the CMC10P.
- (3) Make changes to the uploaded text file and download to the CMC10P again.
- (4) Reset again.

The text file is in CSV format.

 **Note**

For the precautions for editing, see Appendix.

- **Method to “create the parameter file first, then download it to the CMC10P”**

- (1) Creating a file

A parameter file can be created by any of the following methods:

- Upload the internal parameter from the CMC10P and save it as a temporary file. Then edit the file.
- Write the parameter in the mapping sheet provided by Yamatake and save it in CSV format. The sheet is an Excel file. When saved in CSV format, some commas (,) may be missed compared with the file of 1. However, it can be downloaded as is.
- Create a file in the specified format. See Appendix.

- (2) After creating a file, download it to the CMC10P.

Check to make sure that the [NORMAL/SYSTEM] selector switch has been set to [NORMAL] and reset again.

 **Note**

For the precautions for editing, see Appendix.

■ Setting Up the Local Device

For the communication between the CMC10P and a local device, it is necessary to make the communication settings in the local device.

Set up the local device as follows:

Use the same set values as those in the parameter file.

Device address :1 to 31 (Avoid overlaps among the devices)

Transmission speed :19200 or 9600 bps

Data length :8 bits

Parity, stop bit :Either of “even parity and 1 stop bit” or “no parity and 2 stop bits” (Cannot be used together)

! Handling Precautions

- Only the DMC10 supports the transmission speed of 19200 bps.
- When you use the automatic mapping, make the communication settings of the local device in advance.
- In other cases, make the communication settings of the local device following the settings in the parameter file.

■ Setting Up the Terminal and Sample Operation

● Sample terminal setup

The setting method described here uses the hyper terminal attached to Windows95.

- CMC10P Properties - [Phone Number]
 - (1) Choose [Properties] in the [File] menu.
 - (2) Set up the [Phone Number] as shown on the following screen:
The [COM1] stands for the communication port 1 of your PC.



- COM1 Properties - [Phone Number] - [Port Settings]
 - (1) Press the [Configure] button on the [Phone Number] screen.
 - (2) Set up the [Port Settings] as shown on the following screen:

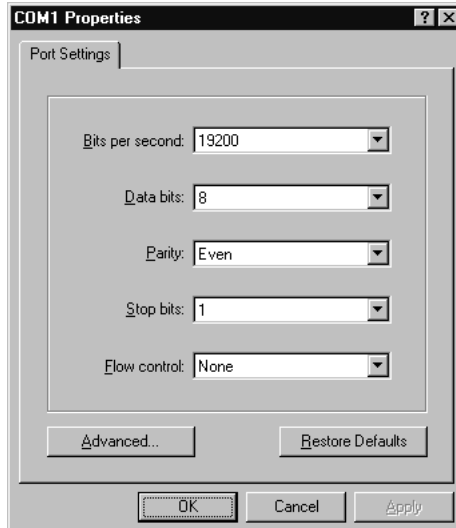

- COM1 Properties - [Phone Number] - [Port Settings] - [Advanced]
 - (1) Press the [Advanced] button on the [Port Settings] screen.
 - (2) Set up the [Advanced Port Settings] as shown on the following screen:
 - (3) Press the **OK** button.

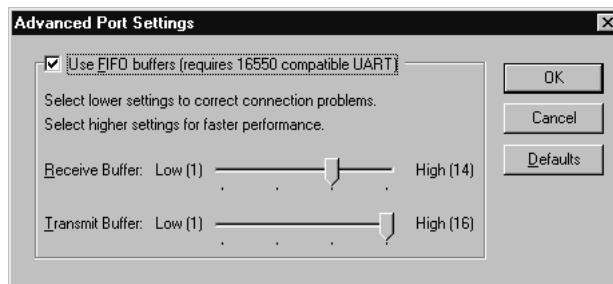

- CMC10P Properties - [Settings]
 - (1) Choose the [Settings] tab.
 - (2) Set up the [Settings] as shown on the following screen:

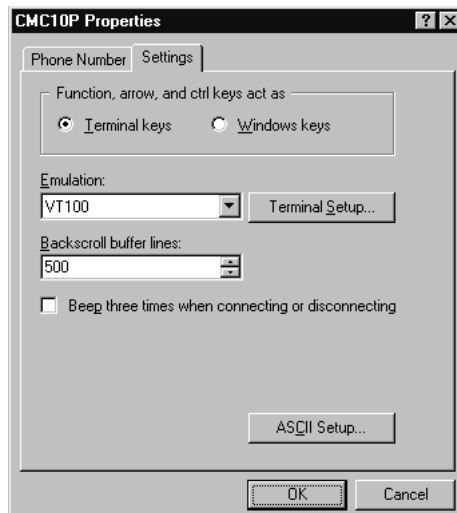

- CMC10P Properties - [Settings] - [Terminal Settings]
 - (1) Press the [Terminal Setup] button on the [Settings] screen.
 - (2) Set up the [Terminal Settings] as shown on the following screen:
 - (3) Press the **OK** button.

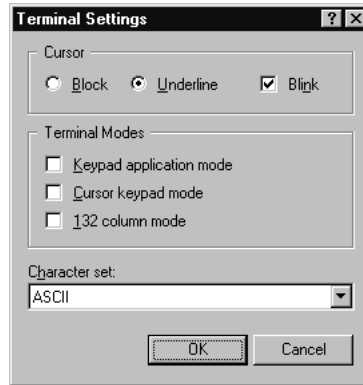

- CMC10P Properties - [Settings] - [ASCII Setup]
 - (1) Press the [ASCII Setup] button on the [Settings] screen.
 - (2) Set up the [ASCII Setup] as shown on the following screen:
 - (3) Press the **OK** button.

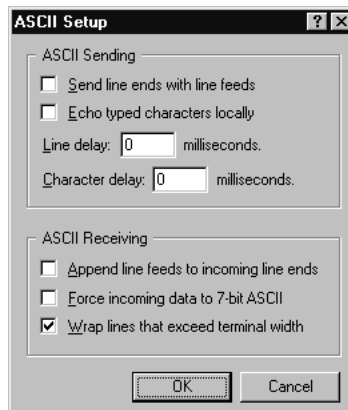

Press the **OK** button on the CMC10P Properties - [Settings] to end the operation.

- Uploading the segment mapping (when storing it in a file)
 - (1) Preparation for creating a file
 - Choose Menu - [Transfer] - [Capture Text]

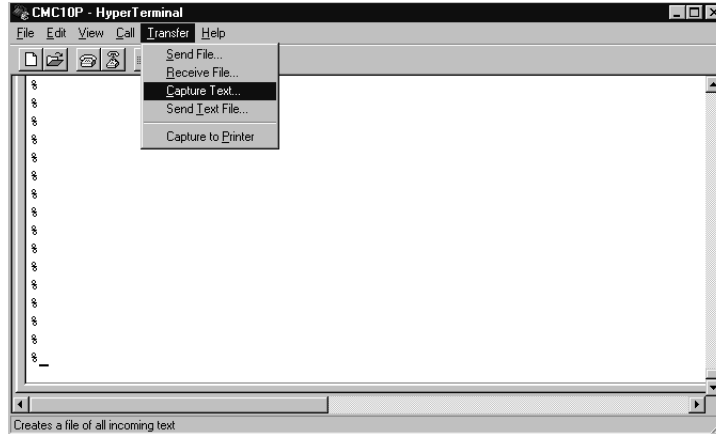

Enter a file name.

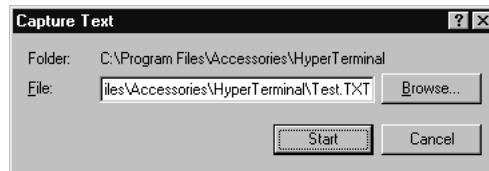

After entry, press the [Start] button.

From now on, the memory in the PC buffers all the characters entered via the keyboard and received from the CMC10P.

- (2) Uploading

Enter [cmc_-u], then press [Return], and the CMC10P settings will appear.

[cmc_-u] command entry screen

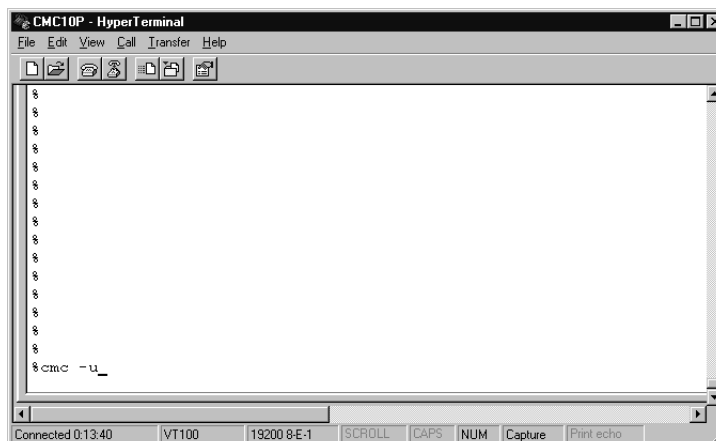

- Monitoring of the connected local devices
Enter “cmc_-” and press [Return]. The connected local devices are displayed.
- Reading the input area on the host on a word basis
Enter “cmc_-i_[address]” and press [Return]. The data at the specified address will appear. The address is the address inside the CMC10P, which is 0-63.
- Reading the output area on the host on a word basis
Enter “cmc_-o_[address]” and press [Return]. The data at the specified address will appear. The address is the address inside the CMC10P, which is 0-63.
- Reading the data input from a local device in the internal memory on a byte basis
Enter “cmc_-r_[dp_addr]_[len]” and press [Return]. The data at the specified address will appear. The dp_addr is the address in the memory, which is 0-7FFh. The len is the data count, which is 1-200h.
- Writing the output data to a local device directly to the internal memory on a word basis
Enter “cmc_-w_[dp_addr]_[data]” and press [Return]. The data at the specified address will appear. The dp_addr is the address in the memory, which is 0-7FEh. The data is the write data, which is 0-fffh (16 bits).
The CMC10P serves as a remote device station and is assigned as I/O in the data area of the host.

5 - 2 Linking with the Host

The assigned I/O area is treated as an area divided on a segment basis and the data exchange is performed with the connected local devices. The outline of the operation is as follows:

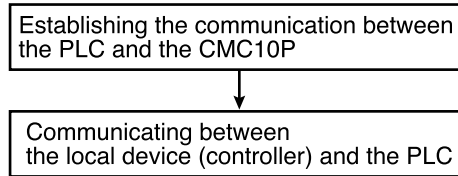

■ Overview of the Link Area Mapping

The data of the thermoregulator assigned in each segment are assigned in the I/O area of the host.

	Link area	
	Input	Output
Total size (in words)	70	70
Configuration (in words)	64 (data area) 4 (command area) 2 (status area)	64 (data area) 4 (command area) 2 (status area)
Description	Used to input the statuses of analog systems and CPL devices.	Used to output the statuses of analog systems and CPL devices.
Area	PIW*	PQW*

*This is in the case when the host is the PLC S7 series made by Siemens AG.
 The data area is segment data.
 The command area is used to read/write data aperiodically on a word basis.
 The status area shows the statuses of the CMC10P and the local devices.
 For details of each area, see Appendix.

● Precautions for creating the host program

Make the host program so that it checks the error bit map in the input status area at the startup.

The CMC10P has an update enable/disable function which determines whether the output data received from the host is reflected to the local device or not.

For details, “● Detailed status area” in Appendix on page APPENDIX-3.

5 - 3 Sample Ladder

This section shows a sample system configuration and describes the unit setup, programming and validation.

■ Sample System Configuration

This is a system with a remote device station connected.

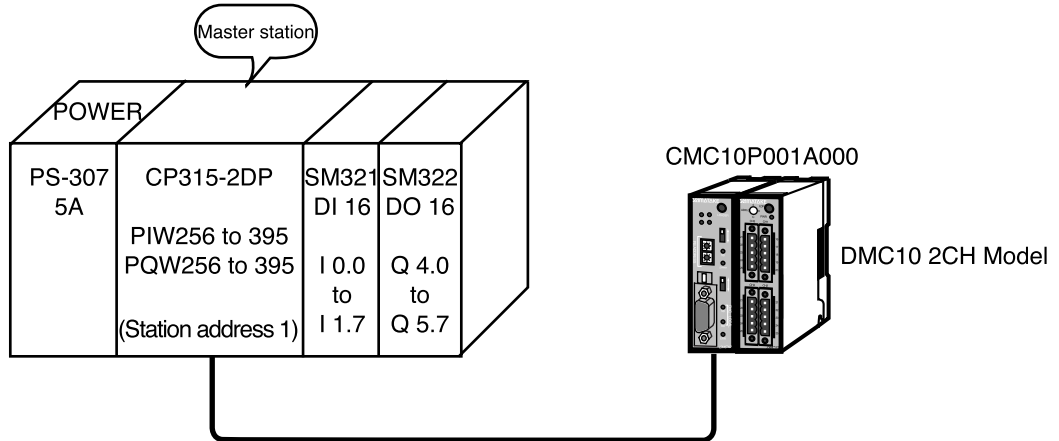

■ Setting Up the CMC10P

This is the setting for the switches of the remote device station.

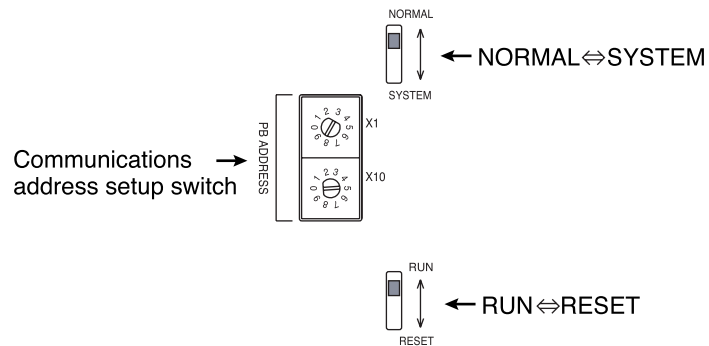

■ Sample Ladder Diagram

Contents of each word

- PIW258 :INPUT DATA
- PIW392 :INPUT STATUS
- PIW394 :INPUT ERROR BIT MAP
- PQW258 :OUTPUT DATA
- PQW392 :OUTPUT ENABLE/DISABLE

Block:OB1

Block: OB1 "Main Program Sweep (Cycle)"

Network: 1

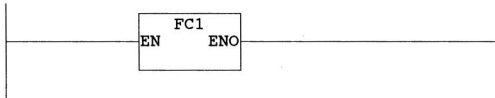

Block:FC1

Block: FC1

Network: 1

INITIALIZE TIMER 500MS

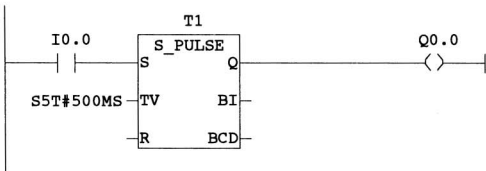

Network: 2

INITIALIZE

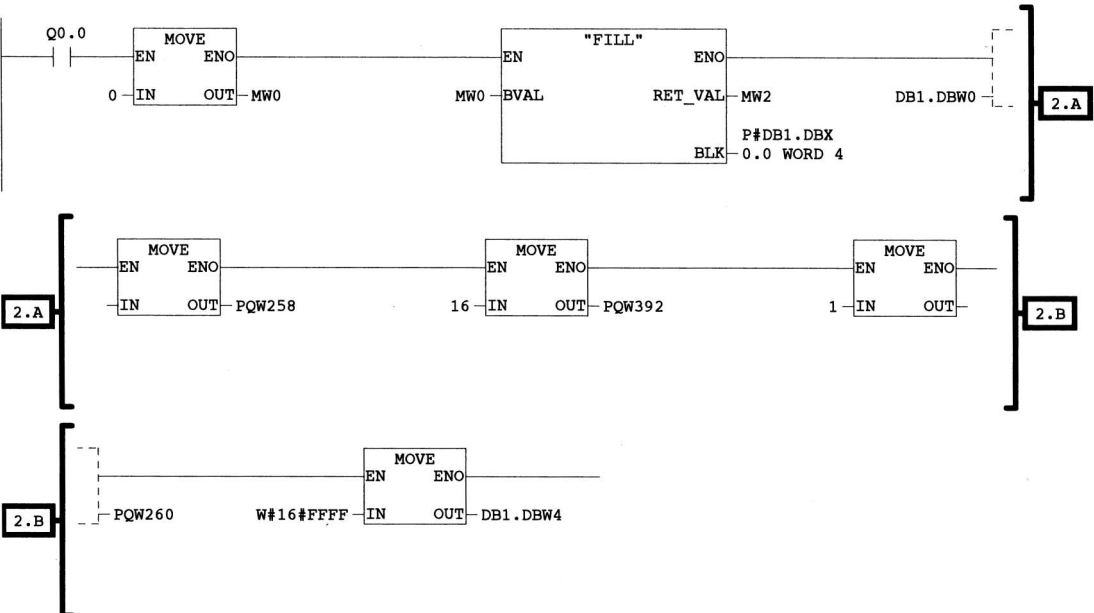

Network: 3
 STATUS AREA CHECK

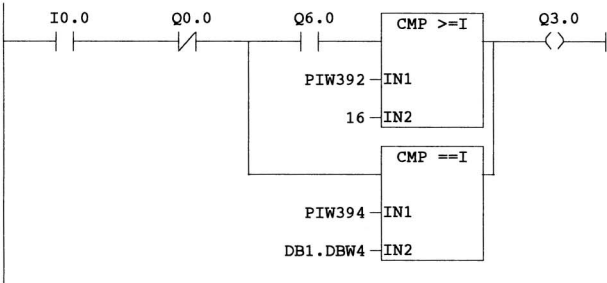

Network: 4
 Q3.0 >=1Sec ON(Output status is not update) -> Q5.0 ON

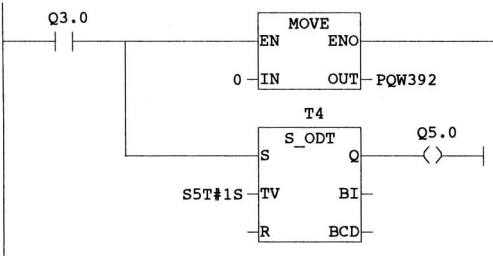

Network: 5

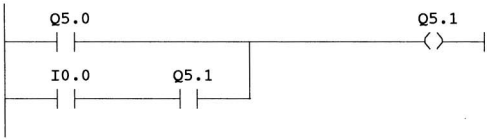

Network: 6

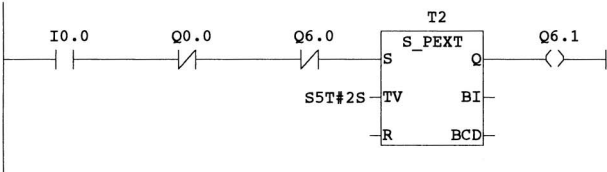

Network: 7

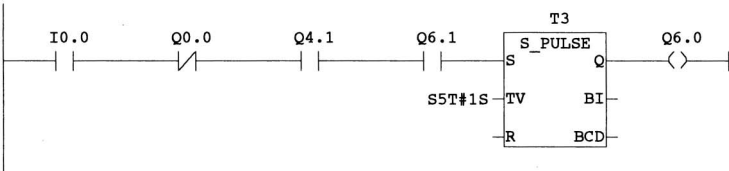

Network: 8
 INPUT DATA CHECK. IF OK, OUTPUT DATA IS INCRIMENTED.

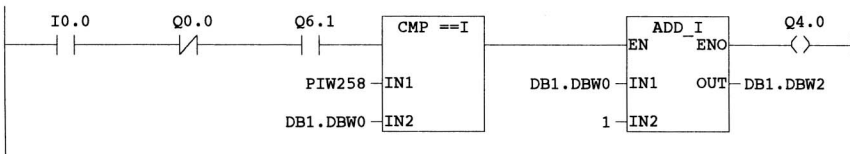

Network: 9
Data is not update >=1Sec -> Q5.2 ON

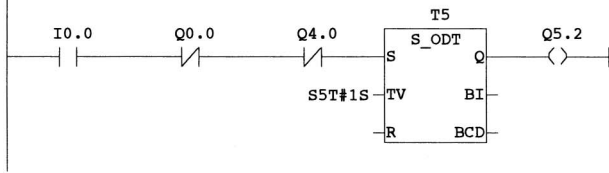

Network: 10

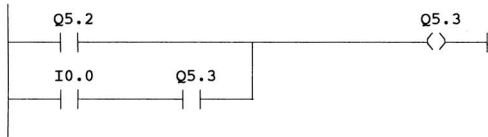

Network: 11
IF DATA = 50 -> DATA = 0

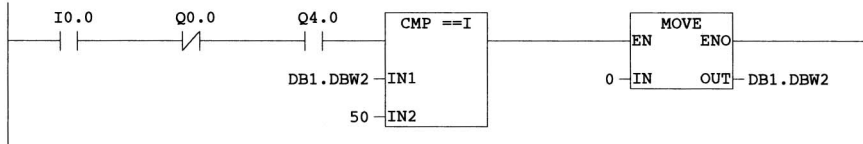

Network: 12
OUTPUT DATA SET. WRITE ENABLE/DISABLE BIT SET ENABLE.

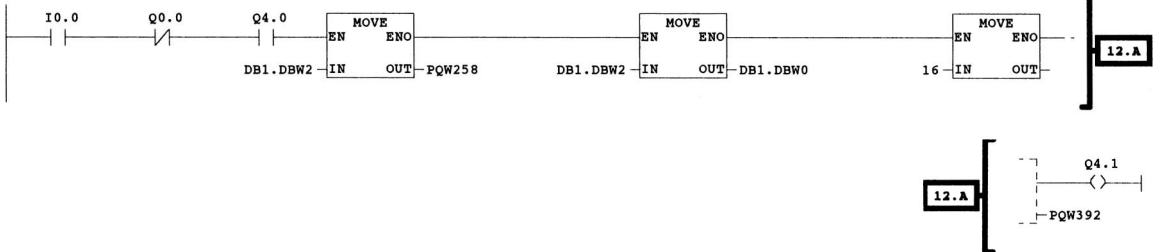

Block:DB1

Block: DB1

Address	Name	Type	Initial value	Comment
0.0		STRUCT		
+0.0	D1	WORD	W#16#0	SetUp Data
+2.0	D2	WORD	W#16#0	Counter
+4.0	D3	WORD	W#16#0	
+6.0	D4	WORD	W#16#0	CMC10P Error bit map
=8.0		END STRUCT		

Chapter 6 TROUBLESHOOTING

■ Errors on CMC10P

LED status			Name	Description	Remedies
POWER	SYSTEM	ERR			
○	○	●	Program area error	An error was detected in the program at start-up.	Reboot the system by resetting it. If the same phenomenon persists, issue a repair order.
○	○	●	RAM area error	An error was detected in the RAM area at start-up.	
○	●	⊛*	PROFIBUS communications circuit initialization error	An error was detected in the communications circuit at start-up.	

●:Lit ○:Unlit ⊛:Blinking *(1Hz) X 5 times, then reset.

■ PROFIBUS Communications Errors

LED status			Description	Remedies
PB ERR	ON LINE	OFF LINE		
⊛ (1Hz)	○	●	PROFIBUS slave configuration error	Check the configuration.
⊛ (2Hz)	○	●	An error in the user parameter data	Check the parameter for PROFIBUS communications.
⊛ (4Hz)	○	●	PROFIBUS communications ASIC initialization error	Reboot the system by resetting it. If the same phenomenon persists, issue a repair order.

●:Lit ○:Unlit ⊛:Blinking

■ CPL Communications Errors

The SD and RD LEDs blink while communication is normal.

If the SD and RD LEDs become off for one or two seconds or stay off, a communications error may have occurred. Check the connection with the local devices and the statuses of the devices.

Note

For PROFIBUS communications and CPL communications, you can perform a communications test separately for one with the other disconnected. For the testing procedures, see “Appendix”.

Chapter 7. SPECIFICATIONS

■ Communications Specifications

Item		Specifications					
PROFIBUS-DP HOST<=>CMC	Communications system	Polling system					
	Synchronization	Frame synchronization					
	Transfer route type	Bus type					
	Transmission speed	12M/6M/3M/1.5M/500k/187.5k/93.75k/19.2k/9.6k bps					
	Occupied word count	70 words for input and output respectively (64 words for the data, 4 words for the command, and 2 words for the status)					
	Model type	General					
	Remote station no.	0 to 99					
	Max. transmission distance *1 (Sample max. transmission distance with a cable of type A)	Transmission speed	12M	1.5M	500k	187.5k	93.75k or less
		Total length	100m	200m	400m	1000m	1200m
	Connecting cable	Special cable for PROFIBUS					
	Terminating resistor	Built in the CMC10P					
Connector (Recommendation)	6GK 1500-0FC00 6GK 1500-0EA02 made by Siemens AG						
CPL communications CMC<=>LOCAL	Communications system	Half duplex					
	Synchronization	Start-stop synchronization					
	Transfer route type	Bus type (RS-485 compliant: 3-lead type)					
	Transmission speed	9600 / 19200 bps					
	Transmission distance	Max. 500m					
	Max. connected units	16 units (8 units when used in the 8-segment mode)					
	Data format	8bit/even parity/1 stop bit					
	Local address	1 to 31 (local station address)					
	Connectable models	DMC10 series					
Loader communications CMC <=> PC (terminal communications)	Communications system	Half duplex					
	Synchronization	Start-stop synchronization					
	Transfer route type	Use the special cable 81440793-001 (optionally available)					
	Control system	TTY protocol					
	Transmission speed	19200 bps					
	Data format	8bit/even parity/1 stop bit					

* For details, see "Installation Guideline for PROFIBUS-DP/FMS" issued by PROFIBUS Nutzerorganisation e.V.

■ General Specifications

Item		Specifications
Rated power voltage		24Vdc
Operating power voltage		21.6 to 26.4Vdc
Power consumption		5W (in operating state)
Insulation resistance		Min. 50MΩ by 500Vdc megger (across case or ground terminal and power terminal)
Dielectric strength		500Vac, for 1min (across case or ground terminal and power terminal)
Isolation		<p>— Solid line: isolated - - - Dotted line: not isolated</p>
Operating conditions	Ambient temperature	0 to 45°C
	Ambient humidity	30 to 90%RH
Transport/storage conditions	Storage temperature	-20 to +70°C
	Storage humidity	10 to 95%RH
	Vibration resistance	Max. 4.9m/s ²
	Impact resistance	Screw mount: max. 392m/s ² DIN rail mount: max. 196m/s ²
	Package drop test	Drop height 60cm, free fall
Tightening torque	Connector for host communications connection	Terminal: 0.8N·m Mount: 0.8N·m
	Power and local communications terminal	0.8 to 1N·m
Mounting		Screw mount or DIN rail mount
Mask/case	Mask/case material	Mask: polycarbonate Case: polycarbonate Base: polycarbonate
	Mask/case color	Mask: navy blue Case: light gray Base: light gray
Standard accessories (User's Manual)		CP-UM-5243E Communication Controller CMC10P (PROFIBUS-DP/CPL Converter)
Separate accessories (User's Manual)		CP-SP-1126E Communication Controller CMC10P (PROFIBUS-DP/CPL Converter) Design manual
Mass		Approx. 200g
Applicable standards		EN50081-2 EN-50082-2

● Optional Parts (sold separately)

Part	Model No.	Description
loader cable	81440793-001	It is a cable for setting up CMC10P

■ External Dimensions

Unit: mm

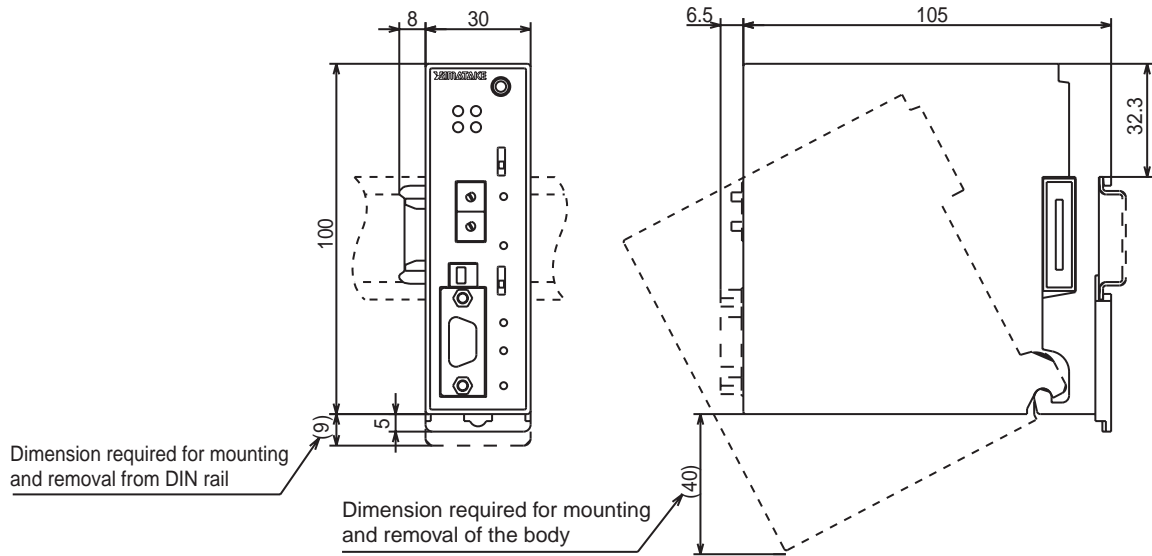

APPENDIX

■ Input/Output Mapping

● Input/output area profile (8 segments)

Area	Input	Sample mapping	Area	Output	Sample mapping
Input area 64Word	Seg1 IN data 1	PIW256	Output area 64Word	Seg1 OUT data 1	PQW256
	Seg1 IN data 2	PIW258		Seg1 OUT data 2	PQW258
	Seg1 IN data 3	PIW260		Seg1 OUT data 3	PQW260
	Seg1 IN data 4	PIW262		Seg1 OUT data 4	PQW262
	Seg1 IN data 5	PIW 264		Seg1 OUT data 5	PQW264
	Seg1 IN data 6	PIW 266		Seg1 OUT data 6	PQW266
	Seg1 IN data 7	PIW 268		Seg1 OUT data 7	PQW268
	Seg1 IN data 8	PIW 270		Seg1 OUT data 8	PQW270
	•	•		•	•
	•	•		•	•
	•	•		•	•
	Seg8 IN data 1	PIW368		Seg8 OUT data 1	PQW368
	Seg8 IN data 2	PIW370		Seg8 OUT data 2	PQW370
	Seg8 IN data 3	PIW372		Seg8 OUT data 3	PQW372
	Seg8 IN data 4	PIW374		Seg8 OUT data 4	PQW374
	Seg8 IN data 5	PIW 376		Seg8 OUT data 5	PQW376
Seg8 IN data 6	PIW 378	Seg8 OUT data 6	PQW378		
Seg8 IN data 7	PIW 380	Seg8 OUT data 7	PQW380		
Seg8 IN data 8	PIW 382	Seg8 OUT data 8	PQW382		
Command area 4Word	Device address	PIW384	Command area 4Word	Device address	PQW384
	Local station access address	PIW386		Local station access address	PQW386
	Extended input data	PIW388		Extended output data	PQW388
	Request completion status	PIW390		Request	PQW390
Status area 2 words	Status	PIW392	Status area 2 Word	Output enable	PQW392
	Error bit map	PIW394		Spare	PQW394

* The sample mapping is that for the PLC S7 series made by Siemens AG.

● **Input/output area profile (16 segments)**

Area	Input	Sample mapping	Area	Output	Sample mapping
Input area 64 Word	Seg1 IN data 1	PIW256	Output area 64 Word	Seg1 OUT data 1	PQW256
	Seg1 IN data 2	PIW258		Seg1 OUT data 2	PQW258
	Seg1 IN data 3	PIW260		Seg1 OUT data 3	PQW260
	Seg1 IN data 4	PIW262		Seg1 OUT data 4	PQW262
	•	•		•	•
	•	•		•	•
	•	•		•	•
	•	•		•	•
	Seg16 IN data 1	PIW376		Seg16 OUT data 1	PQW376
Seg16 IN data 2	PIW378	Seg16 OUT data 2	PQW378		
Seg16 IN data 3	PIW380	Seg16 OUT data 3	PQW380		
Seg16 IN data 4	PIW382	Seg16 OUT data 4	PQW382		
Command area 4 Word	Device address	PIW384	Command area 4 Word	Device address	PQW384
	Local station access address	PIW386		Local station access address	PQW386
	Extended Input data	PIW388		Extended Output data	PQW388
	Request completion status	PIW390		Request	PQW390
Status area 2 words	Status	PIW392	Status area 2 words	Output enable	PQW392
	Error bit map	PIW394		Spare	PQW394

*The sample mapping is that for the PLC S7 series made by Siemens AG.

● **Detailed command area**

● **Input**

Name	Description	Value
Device address	The address of the local device specified in the output command area is entered.	Ranging from 1 to 31
Local station access address	The address of the data specified in the output command area is entered.	Ranging from 0 to 32767
Input data	The data at the specified address is entered.	Input value
Request completion status	The result of the read/write request	0000 ₁₆ : Request acceptable 0081 ₁₆ : Write request completed 0082 ₁₆ : Read request completed ##8* ₁₆ : Request error (## indicates the error code.) See the table below.

The * indicates that a request code (1 or 2) is set here.

	Completion status (hexadecimal)	Remarks
Normal end	008*	
No response from the local station	818*	
Error in the application layer	828*	
Abend code received	##8*	An abend code from the local station is set in ##.
Data buffering not executed	888*	
Command error	FF80	<ul style="list-style-type: none"> • The request is other than 1 and 2 when a write/read request is accepted. • The device address is out of the range. • The read/write address is out of the range.

The * indicates that a request code (1 or 2) is set here.

● Output

Name	Description	Value
Device address	Set the address of the local device.	Ranging from 1 to 31
Local station access address	Set the internal data address of the local device.	Ranging from 0 to 32767
Output data	Input the output data.	Output value
Request	Use for clearing status and read/write data	0000 ₁₆ : Status clear 0001 ₁₆ : Write request 0002 ₁₆ : Read request

● Procedures from the host

- (1) Check to make sure that the value of request completion status in the command area is 0 (request acceptable).
- (2) If the device address, local station access address and the request in the output command area are for write, set data, then set a write or read request.
If the request is for read, set no data.
- (3) Wait until the bit 7 of the request completion status in the input command area becomes 1 (request completed).
- (4) If the request completion status is not an error, check to make sure that the device address and the local station access address in the command area on the input side are identical with those on the output side.
- (5) If the request is read, read the input data in the command area.
- (6) Reset the request in the command area to 0.

● Detailed status area

● Status (input)

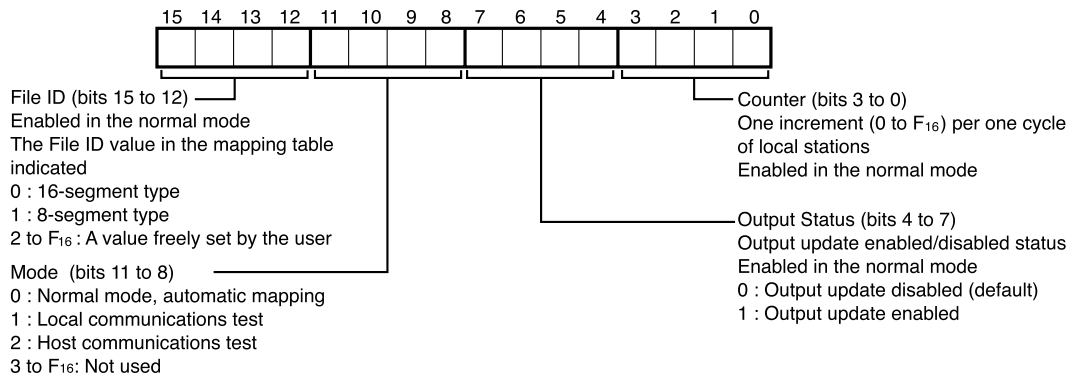

● Error bit map

The errors in the local stations are indicated by error bit maps for each segment. If any error has occurred in a segment, the corresponding error bit is turned on. This is equivalent to the error presence/absence of the alignment in 4 word increments. If the mapping is for 16 segments, one bit represents the error of one segment.

If the mapping is for 8 segments, two bits represent the error of one segment.

	15	14	13	12	11	10	9	8	7	6	5	4	3	2	1	0
	Error bit map															
I/O address	63-61	60-57	56-53	52-49	48-45	44-41	40-37	36-33	32-29	28-25	24-21	20-17	16-13	12-9	8-5	4-0
16 segment No.	16	15	14	13	12	11	10	9	8	7	6	5	4	3	2	1
8 segment No.	8		7		6		5		4		3		2		1	

● Enable/disable output update

This is an area to make the output update enabled/disabled for 64 words (excluding the command area) in the output area.

The default is “output update disabled”. Just when the output update is enabled, all the outputs are scanned and all the data is output to the local stations.

All the data is output only once just when the output update is enabled. Make sure to set all the data before enabling. If the output data is changed during enabled status, only the changed data is output.

Disable output update

00₁₆ : Disables the output update. Does not transfer the write data from the host to the local devices. (Default)

10₁₆ → 00₁₆ : After stopping the data update to the local devices, the CMC10P makes the Output Status in the status 00₁₆ and stops output to the local devices.

Enable output update

10₁₆ : Enables the output update and outputs the data from the host to the local devices.

Scans 00₁₆ → 10₁₆ and updates the CMC10P internal data as a single unit. Then makes the Output Status in the status 10₁₆. From then on, the output area is kept enabled.

■ LED Indications

Mode	Status	Power	System	SD	RD	Err
Normal Mapping Communications test	From power on until start of communications with local devices	★ (1Hz)	●	○	○	○
	While collecting data from local device	●	○	★	★	○
Normal	An error in communications with local device	●	○	★	★or○	●
	During local device automatic mapping	●	★(1Hz)	○	○	○
Auto	When local device automatic mapping completed	●	●	○	○	○
	Communications test (host)	●	★(1Hz)	○	○	○
Communications test	Communications test (local)	●	★(1Hz)	★	★or○	○or●

●:Lit ○:Unlit ★:Blinking

Status	PROFIBUS-DP		
	Diag	ON Line	OFF Line
Normally communicating	○	●	○
Offline	○	○	●
A configuration error	★ (1Hz)	○	●
An error in the user parameter data	★ (2Hz)	○	●
An initialization error in the PROFIBUS communication ASIC	★ (4Hz)	○	●

●:Lit ○:Unlit ★:Blinking

■ Parameter File Format (Text Format)

A file is composed of the header the data.

In the example below, L1 to L6 is the header; L7 and the following part is the data.

The example is the case of 8 segments.

Also see the parameter sheet (on page APPENDIX-8).

Please be sure to put a CR code into the end of the last line.

8 segments

L1,CMC10P 8segments mapping sheet

L2,File ID(0-15),

L3,TAG(16char),

L4,CPL Transmission speed(bps),1,1:19200/ 2:9600

L5,Data format,1,1:8bit even 1stop/ 2:8bit non 2stop

L6,Seg,I/O addr,Dev ID,Dev addr,IN addr,Label(16char),OUT addr,Label(16char)

L7,1,0,,,,,

L8,1,1,,,,,

L9,1,2,,,,,

L10,1,3,,,,,

L11,1,4,,,,,

L12,1,5,,,,,

L13,1,6,,,,,

L14,1,7,,,,,

L15,2,8,,,,,

L16,2,9,,,,,

L17,2,10,,,,,

L18,2,11,,,,,

L19,2,12,,,,,

L20,2,13,,,,,

L21,2,14,,,,,

L22,2,15,,,,,

L23,3,16,,,,,

L24,3,17,,,,,

L25,3,18,,,,,

L26,3,19,,,,,

L27,3,20,,,,,

L28,3,21,,,,,

L29,3,22,,,,,

L30,3,23,,,,,

L31,4,24,,,,,

L32,4,25,,,,,

L33,4,26,,,,,

L34,4,27,,,,,

L35,4,28,,,,,

L36,4,29,,,,,

L37,4,30,,,,,

L38,4,31,,,,,

L39,5,32,,,,,

L40,5,33,,,,,

L41,5,34,,,,,
L42,5,35,,,,,
L43,5,36,,,,,
L44,5,37,,,,,
L45,5,38,,,,,
L46,5,39,,,,,
L47,6,40,,,,,
L48,6,41,,,,,
L49,6,42,,,,,
L50,6,43,,,,,
L51,6,44,,,,,
L52,6,45,,,,,
L53,6,46,,,,,
L54,6,47,,,,,
L55,7,48,,,,,
L56,7,49,,,,,
L57,7,50,,,,,
L58,7,51,,,,,
L59,7,52,,,,,
L60,7,53,,,,,
L61,7,54,,,,,
L62,7,55,,,,,
L63,8,56,,,,,
L64,8,57,,,,,
L65,8,58,,,,,
L66,8,59,,,,,
L67,8,60,,,,,
L68,8,61,,,,,
L69,8,62,,,,,
L70,8,63,,,,,
L71,End of file

■ Parameter Sheet

Precautions for creating parameters

Use TAG for parameter file identification.

If you set a value other than 1 or 2 for CPL Transmission speed (bps), it becomes error.

If you set a value other than 1 or 2 for Data format, it becomes error.

Use alphanumeric characters for entry.

The parameter sheet contains the items and descriptions shown below.

Line No.	Title								
L1	CMC10P 16segments mapping sheet								
L2	FileID(0-15)	File ID No. 0 : 16Segments 1: 8Segments							
L3	TAG(16char)	TAG name							
L4	CPLTransmission speed(bps)	1or2	1:19200/2:9600 Input "1" or "2"						
L5	Dataformat	1or2	1:8biteven1stop/2:8bitnor2stop						
L6	Seg	I/Oaddr	Dev ID	Devaddr	INaddr	Label(16char)	OUT addr	Label(16char)	Title
L7		1	0	4509	1	1004	PV(1CH)		
L8		1	1	4509	1	1008	SP1	1008	SP1
L9		1	2	4509	1	1046	Event		
L10		1	3	4509	1	1032	Run/Ready1		
L11		2	4		2				Comment
L12		2	5		2				Comment
L13		2	6		2				Comment
L14		2	7		2				OUT area data address
	Segment No.		Device ID.*						
	Input/Output area No.				IN area data address				
			Local devices address						
L71	Endoffile								

* In the case of DMC10, the value is 4509.

In the case of other devices, please do not set up the value.

● 8 segments

L1	CMC10P 8segments mapping sheet							
L2	FileD(0-15)							
L3	TAG(16char)							
L4	CPLTransmission speed(bps)	lor2	1:19200/2:9600					
L5	Dataformat	lor2	1:8biteven1stop/2:8bitnon2stop					
L6	Seg	I/Oaddr	Dev ID	Dev addr	INaddr	Label(16char)	OUT addr	Label(16char)
L7		1	0					
L8		1	1					
L9		1	2					
L10		1	3					
L11		1	4					
L12		1	5					
L13		1	6					
L14		1	7					
L15		2	8					
L16		2	9					
L17		2	10					
L18		2	11					
L19		2	12					
L20		2	13					
L21		2	14					
L22		2	15					
L23		3	16					
L24		3	17					
L25		3	18					
L26		3	19					
L27		3	20					
L28		3	21					
L29		3	22					
L30		3	23					
L31		4	24					
L32		4	25					
L33		4	26					
L34		4	27					
L35		4	28					
L36		4	29					
L37		4	30					
L38		4	31					
L39		5	32					
L40		5	33					
L41		5	34					
L42		5	35					
L43		5	36					
L44		5	37					
L45		5	38					
L46		5	39					
L47		6	40					
L48		6	41					
L49		6	42					
L50		6	43					
L51		6	44					
L52		6	45					
L53		6	46					
L54		6	47					
L55		7	48					
L56		7	49					
L57		7	50					
L58		7	51					
L59		7	52					
L60		7	53					
L61		7	54					
L62		7	55					
L63		8	56					
L64		8	57					
L65		8	58					
L66		8	59					
L67		8	60					
L68		8	61					
L69		8	62					
L70		8	63					
L71	Endbfile							

APPENDIX

● 16 segments

L1	CMC10P 16segments mapping sheet						
L2	FileID(0-15)						
L3	TAG(16char)						
L4	CPLTransmission speed(bps)	lor2	1:19200/ 2:9600				
L5	DataFormat	lor2	1:8bitevenlstop/2:8bitnor2stop				
L6	Seg	I/Oaddr	Dev ID	Devaddr	INaddr	Label(16char)	OUT addr Label(16char)
L7		1	0				
L8		1	1				
L9		1	2				
L10		1	3				
L11		2	4				
L12		2	5				
L13		2	6				
L14		2	7				
L15		3	8				
L16		3	9				
L17		3	10				
L18		3	11				
L19		4	12				
L20		4	13				
L21		4	14				
L22		4	15				
L23		5	16				
L24		5	17				
L25		5	18				
L26		5	19				
L27		6	20				
L28		6	21				
L29		6	22				
L30		6	23				
L31		7	24				
L32		7	25				
L33		7	26				
L34		7	27				
L35		8	28				
L36		8	29				
L37		8	30				
L38		8	31				
L39		9	32				
L40		9	33				
L41		9	34				
L42		9	35				
L43		10	36				
L44		10	37				
L45		10	38				
L46		10	39				
L47		11	40				
L48		11	41				
L49		11	42				
L50		11	43				
L51		12	44				
L52		12	45				
L53		12	46				
L54		12	47				
L55		13	48				
L56		13	49				
L57		13	50				
L58		13	51				
L59		14	52				
L60		14	53				
L61		14	54				
L62		14	55				
L63		15	56				
L64		15	57				
L65		15	58				
L66		15	59				
L67		16	60				
L68		16	61				
L69		16	62				
L70		16	63				
L71	Endbfile						

■ Communications Tests

● Host communications test (PROFIBUS <=> CMC10P)

This is a mode to check whether the PROFIBUS communications is correctly operating.

Set the system so that communication is available only between the host and the CMC unit.

Set the word increment patterns of 1 to 68 at the 0 word to 67 word addresses respectively as defaults.

If the output data is changed on the host side, the output data is looped back to the corresponding input area.

- (1) Set the dip switch on the rear panel to the host communications test mode.
- (2) Set the [NORMAL/SYSTEM] selector switch on the front panel to [SYSTEM].
- (3) Reset or power off and on the system.

[PROFIBUS input area]

Area	I/O address (in words)	Description
Test area	+00 to 67	The default is a word increment pattern from 1. The changed data in the output area is reflected from then on.
Status area	+68	0200 ₁₆ Fixed to 0200 ₁₆ (host communications test)
	+69	Fixed to FFFF ₁₆

[PROFIBUS output area]

Area	I/O address (in words)	Description
Test area	+00 to 67	The changed data is reflected to the input area.
Output setting area	+68	Output prohibited
	+69	Output prohibited

● **Local communications test (CMC10P <=> local devices)**

This is a mode to check whether the CPL communications is correctly operating. Set the system so that communication is available only between the CMC unit and local devices, then display the input area of the internal memory (DPRAM) via terminal communications. You can check whether the local CPL communications is correctly operating.

- (1) Set the dip switch on the rear panel to the local communications test mode.
- (2) Set the [NORMAL/SYSTEM] selector switch on the front panel to [SYSTEM].
- (3) Reset or power off and on the system.

[PROFIBUS output area]

Area	I/O address (in words)	Description
Input area	+00 to 63	Fixed to 8000 ₁₆
Command area	+64 to 67	Fixed to 0000 ₁₆
Status area	+68	Fixed to 0100 ₁₆ (local communications test)
	+69	Fixed to FFFF ₁₆

[PROFIBUS output area]

Area	I/O address (in words)	Description
Test area	+00 to 67	Output prohibited
Command area	+64 to 67	Output prohibited
Output setting area	+68	Output prohibited
	+69	Output prohibited

Index

-A-
Automatic mapping 5-4

-C-
Cables 4-1
CE marking 1-1
Communications address setup switch 3-1
Communications disconnect switch 5-2
Communications disconnection switch 2-1
Configuration 1-1

-D-
Detailed command area APPENDIX-2
DIN rail stopper 2-1
DIP switch 2-1, 5-2
Downloading the segment mapping 5-12

-E-
Errors 6-1
External Dimensions 7-3

-H-
Host communications 4-3

-I-
Impact resistance 7-2
Input/output area profile (16 segments) APPENDIX-2
Input/output area profile (8 segments) · APPENDIX-1
Installation Procedure 3-2

-L-
LED Indications 2-2
Lever 2-1
Link area 5-15
Link Area Mapping 5-15
Linking Modules 3-1
Loader jack 2-1
Local CPL Communications 4-3
Local CPL communications terminal 2-1

-M-
Mapping types 5-3
Mounting hole 2-1
Mounting Locations 3-1
mounting the base 3-2

-O-
Outline 1-1

-P-
Parameter setup 5-3
Power consumption 7-2
Power Supply 4-2
Power supply terminal 2-1

-R-
Rated power voltage 7-2
Resistor setting switch 2-1

-S-
Sample Ladder 5-16
Sample operation 5-10
Securing on a DIN rail 3-2
Setting Up the Hardware 5-2
Setting Up the Host 5-1
Setting Up the Local Device 5-7
Setting Up the Parameter 5-3
Station address 5-2
Storage humidity 7-2
Storage temperature 7-2

-T-
Terminal setup 5-7
Terminating resistor 4-3
Tightening torque 7-2
TTY protocol 5-3

-U-
Uploading the segment mapping 5-11

-V-
Vibration resistance 7-2

-W-
Wiring Precautions 4-2

Revision History

Printed Date	Manual Number	Edition	Revised pages	Description
02-01	CP-SP-1126E	1st Edition		
02-06		2nd Edition	1-1 5-1 5-3 5-4 5-6 5-7 to 5-9 5-10 5-14 APP.-3 APP.-6 APP.-8	Delete "and recorders" from the explanation. Fig changed. Fig changed. Explanation deleted. (6) and (7) Explanation changed. (4) Explanation changed. (2) expression revised. Screen at the right corrected to following Screen. Enter [cmc] Fig changed. Explanation added. (2) explanation changed. Explanation added. Explanation changed.

Specifications are subject to change without notice.

YAMATAKE

Yamatake Corporation

Control Products Division

Head office : Totate International Building
2-12-19 Shibuya Shibuya-ku Tokyo 150-8316 Japan

Inquiries to : International Business Division

Phone : 81-3-3486-2331, Fax : 81-3-3486-2300 (Sales)

Phone : 81-466-20-2307, Fax : 81-466-27-9264 (Customer Service)

<http://www.yamatake.com>

This has been printed on recycled paper.

Printed in Japan.

1st Edition: Issued in Jan., 2002(M)

2nd Edition: Issued in Jun., 2002(M)