

Single Loop Controller

Models R35, R36

General

Model R35/R36 is a digital indicating controller featuring multi-range inputs and PID control system using new algorithms "RationalLOOP PID (Ra-PID)" and "Just-FITTER".

Up to two control output points (this number of points may vary depending on the model) can be used, which are selectable from the relay contact, motor drive relay, and current.

Features

- Space saving design with a depth of 65mm. The mask of the front panel is also only 5mm thick.
- High accuracy of $\pm 0.1\%$ FS and sampling cycle of 0.1 seconds.
- Multi-range inputs are available for selection, where the input type can be freely changed among RTD, current, and voltage.
- The control method can be selected from any of the ON/OFF control and PID control using "RationalLOOP PID (Ra-PID) + Just-FITTER".
- The heat/cool control is achieved by using two control output points and event outputs.
- The controller is applicable to the communication (3-wire RS-485) as optional.
- The control output types (relay, motor drive relay, and current) can be combined by using the control outputs 1 and 2.
- Event 3 points or 2 points (independent contact), CT input 2 points, DI 4 points, RSP inputs, and RS-485 can be combined to select.

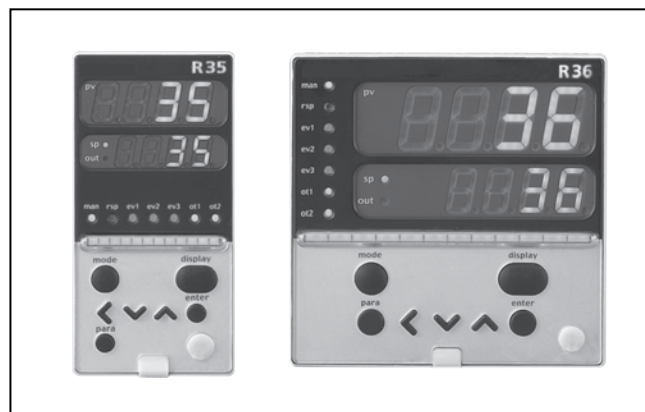

Basic Function Block of Model R35/R36

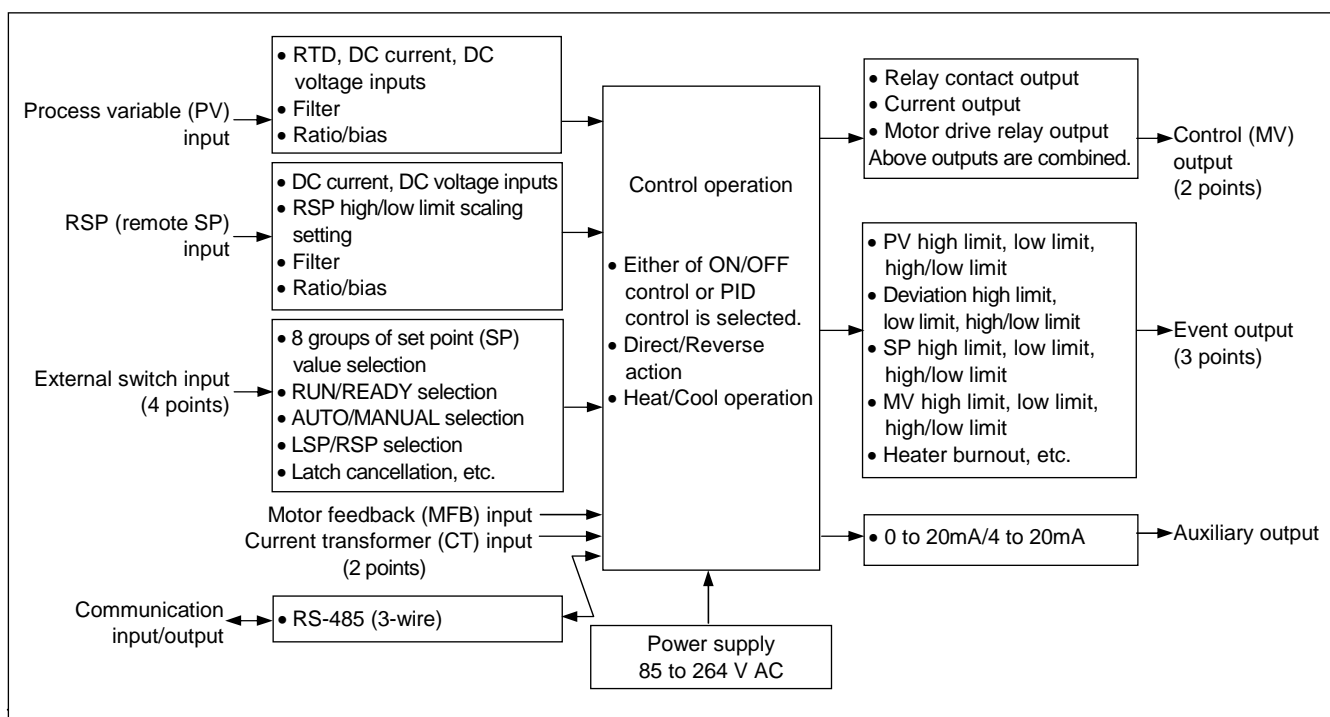

Specifications

PV input	Input type	Multi-range of inputs; RTD, DC current and DC voltage			
	Input sampling time	0.1 s			
	Input impedance	DC voltage input: Min. 1 M Ω / DC current input: Max. 100 Ω			
	Input bias	-1999 to +9999 or -199.9 to +999.9			
	Input bias current	RTD input	1 mA		
		DC voltage input	0-5 V, 1-5 V range: 3.5 μ A or less 0-10V range: 7 μ A or less		
	Display at burnout	RTD input	RTD burnout: Upscale + alarm display (AL01) A-wire burn out: Upscale + alarm display (AL01) B-wire burnout: Upscale + alarm display (AL01, AL03) C-wire burnout: Upscale + alarm display (AL01, AL03) 2 or 3 wires burnout: Upscale + alarm display (AL01, AL03)		
		DC voltage input	Downscale + alarm display (AL02) However, the burnout cannot be detected for the 0 to 10 V range.		
		DC current input	Downscale + alarm display (AL02) However, burnout cannot be detected for the 0 to 20 mA range.		
	Allowable input current	DC current input	Max. 30 mA		
Allowable input voltage	DC current input:	Max. 4 V *Higher voltage (than 4 V) might cause input circuit failure.			
Motor feedback potentiometer input (R1 model)	Allowable resistance	100 to 2500 Ω			
	Burnout detection	AL07 indication			
RSP input	Input type	Linear 0 to 20 mA/4 to 20 mA or Linear 0 to 5 V/1 to 5 V/0 to 10 V			
	Scaling	Possible in a range of -1999 to +9999. Decimal point position is changeable.			
	Sampling cycle	0.1 s			
	Input impedance	DC voltage input: Min. 1 M Ω / DC current input: Max. 100 Ω			
	Input bias current	0 to 5 V, 1 to 5 V ranges: Max. 3 μ A / 0 to 10 V range: Max. 5 μ A			
	Display at burnout	DC voltage input	Downscale + AL06		
		DC current input	Downscale + AL06 (However, burnout cannot be detected for the 0 to 20 mA range.)		
Allowable input voltage	DC current input:	Max. 4 V *Higher voltage (than 4 V) might cause input circuit failure.			
Indications and setting	PV, SP indication method	4-digit, 7-segment LED (PV: Upper green display, SP: Lower orange display)			
	Number of setting points	Max. 8 points			
	Setting method	<, v, or ^ key operation at each digit			
	Setting range	Low to high limit value of the PV range (can be limited by SP low to high limit)			
	Multi-status indicator	Control output status, alarm, or RUN/READY status is indicated.			
	Indication accuracy	± 0.1 %FS ± 1 digit			
	Indication range	See Table 1.			
Control output	Output type	Relay contact output	Motor drive relay output	Current output	
	Control action	Time proportional PID	Position proportional PID	Continuous PID	
	Number of PID groups	Max. 8 groups			
	PID auto-tuning	Automatic PID value setting by limit cycle method. However, one of the following 3 control characteristics can be selected: • Standard • Quick disturbance response • Less up/down fluctuations of PV			
	Output rating	Control output (N.O. side): 250 V AC/30 V DC, 3 A (resistive load) Control Output (N.C. side): 250 V AC/30 V DC, 1 A (resistive load) Service life: 50,000 cycles or more on N.O. side 100,000 cycles or more on N.C. side Min. switching specification: 5 V, 100 mA Min. OFF time / ON time: 250 ms	Contact type: N.O./N.C. contact (2 circuits) Contact rating: 250 V AC, 8 A (resistive load) Service life: 120,000 cycles or more Min. switching specifications: 24V DC, 40 mA	Output type: 0 to 20 mA DC 4 to 20 mA DC Allowable load resistance: Max. 600 Ω Output accuracy: ± 0.1 %FS (± 1 %FS for 0 to 1mA) Output resolution: 1/10000	
	Cycle time (s)	5 to 120	—	—	
	PID control	Proportional band (%FS)	0.1 to 999.9		
		Integral time (s)	0 to 9999 or 0.0 to 999.9		
		Derivative time (s)	0 to 9999 or 0.0 to 999.9		
		Manual set (%)	-10.0 to +110.0		
	Just-FITTER	Overshoot suppression coefficient	0 to 100		
	ON/OFF control	Differential gap ($^{\circ}$ C)	0 to 9999 or 0.0 to 999.9		
	Control operation selection	Direct action or reverse action			
	Heat/Cool control selection	Control output and Event output (Heat/Cool control is disabled when control output is motor drive relay.)			

Auxiliary output	Output type	Current output 0 to 20 mA DC or 4 to 20 mA DC						
	Allowable load resistance	Max. 600 Ω						
	Output accuracy	± 0.1 %FS (± 1 %FS for 0 to 1mA)						
	Output resolution	1/10000						
External contact input (DI)	Number of inputs	Max. 4 points						
	Function	Up to 8 kinds of setting value (SP) selections, PID group selection, RUN/READY selection, AUTO/MANUAL selection, LSP/RSP selection, Auto tuning stop/start, Control action Direct/Reverse selection, SP ramp enable/disable, PV value hold, Max. PV value hold, Min. PV value hold, Timer start/stop, All DO latch cancellation, Advance operation, Step hold						
	Input rating	Dry contact or open collector						
	Min. detection holding time	0.2 s or longer						
	Allowable ON contact resistance	Max. 250 Ω						
	Allowable OFF contact resistance	Min. 100 kΩ						
	Allowable ON-state residual voltage	Max. 1.0 V						
	Open terminal voltage	5.5 V DC ±1 V						
	ON terminal current	Approx. 7.5 mA (at short-circuit), Approx. 5.0 mA (at contact resistance of 250 Ω)						
	Event	Number of output points	2 or 3 points (depending on the model)					
Number of internal event settings		Up to 8 settings						
<p>Event type</p> <ul style="list-style-type: none"> • shows that the ON/OFF is changed at this value. ○ shows that the ON/OFF is changed at a point that 1U is added to this value. <p>U: minimum unit</p>	PV high limit		PV low limit					
	Direct action		Reverse action		Direct action		Reverse action	
	PV high/low limit		Deviation high limit		Direct action		Reverse action	
	Deviation low limit		Deviation high/low limit		Direct action		Reverse action	
	SP high limit		SP low limit		Direct action		Reverse action	
	SP high/low limit		MV high limit		Direct action		Reverse action	
	MV low limit		MV high/low limit		Direct action		Reverse action	
	Heater burnout / Overcurrent		Heater short-circuit		Direct action		Reverse action	

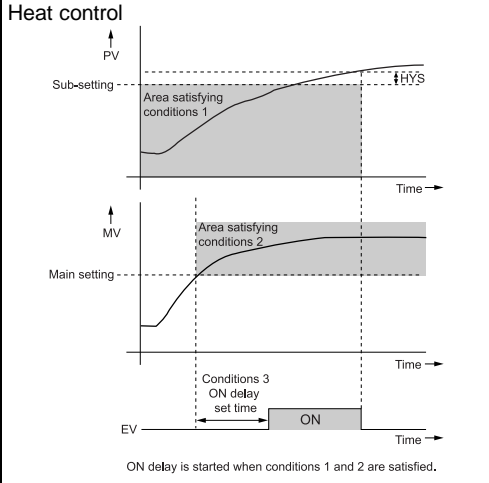
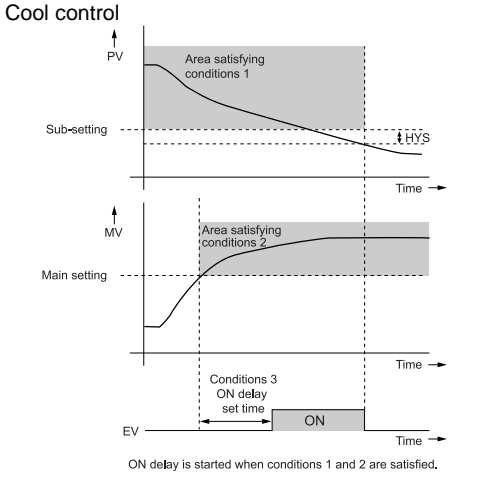
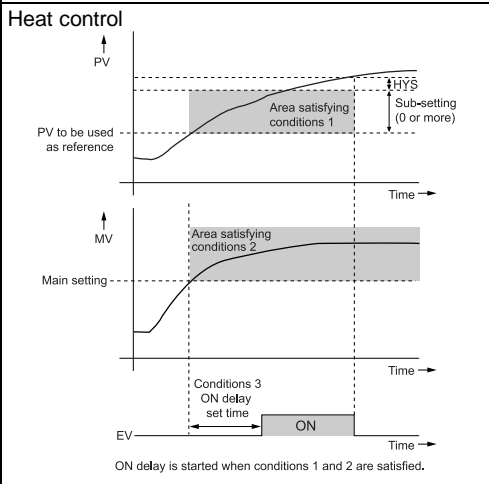
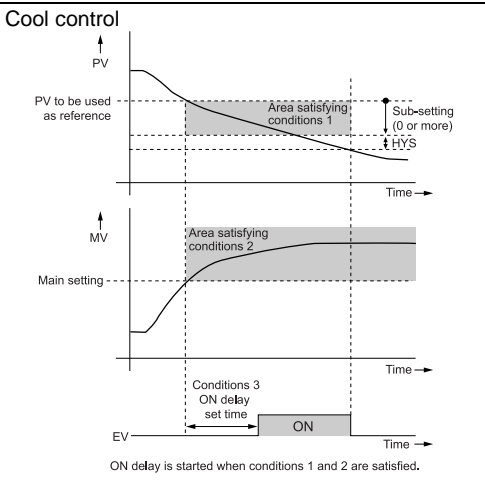
Event	Event type	Loop diagnosis 1	
		<p>The event is turned ON when any PV does not change corresponding to increase/decrease in MV (Manipulated variable). This event is used to detect any fault of final control devices.</p> <ul style="list-style-type: none"> Setting items <ul style="list-style-type: none"> Main setting: MV (Manipulated variable) Sub-setting: PV ON delay time: Diagnosis time Operation specifications <p>The event is turned ON when the value does not reach the PV set in the sub-setting within the diagnosis time (ON delay time) even though the MV exceeding the main setting is held.</p> CAUTION <p>When setting the ON delay, it is necessary to put in "Multi-function setup". The default setting of the ON delay before shipment is 0.0 s.</p> 	
		Direct action	Reverse action
		<p>Heat control</p>  <p>ON delay is started when conditions 1 and 2 are satisfied.</p>	<p>Cool control</p>  <p>ON delay is started when conditions 1 and 2 are satisfied.</p>
		Loop diagnosis 2	
		<p>The event is turned ON when PV does not change corresponding to increase/decrease in MV (Manipulated variable). This event is used to detect any fault of final control devices.</p> <ul style="list-style-type: none"> Setting items <ul style="list-style-type: none"> Main setting: MV (Manipulated variable) Sub-setting: Change in PV from the point that the MV exceeds the main setting. ON delay time: Diagnosis time Operation specifications <p>The event is turned ON when the MV exceeding the main setting is held (conditions 2) and the PV does not reach the value that the sub-setting is added to (subtracted from) the PV at the point where the MV exceeds the main setting within the diagnosis time (ON delay time) (conditions 1).</p> CAUTION <p>When setting the ON delay, it is necessary to put in "Multi-function setup". The default setting of the ON delay before shipment is 0.0 s.</p> 	
		Direct action	Reverse action
		<p>Heat control</p>  <p>ON delay is started when conditions 1 and 2 are satisfied.</p>	<p>Cool control</p>  <p>ON delay is started when conditions 1 and 2 are satisfied.</p>

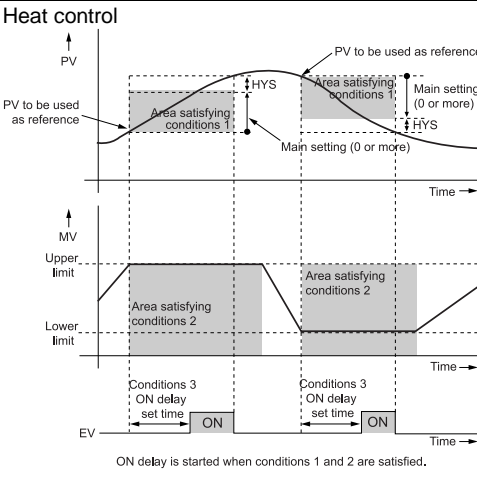
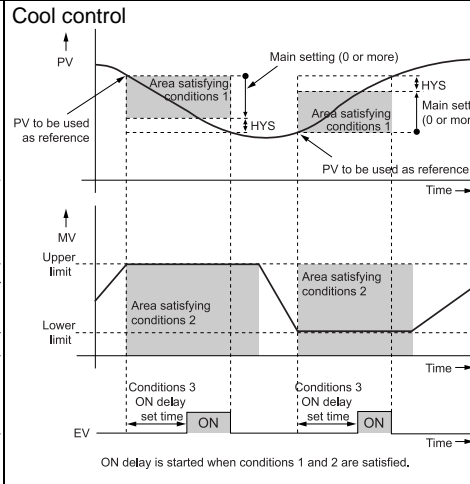
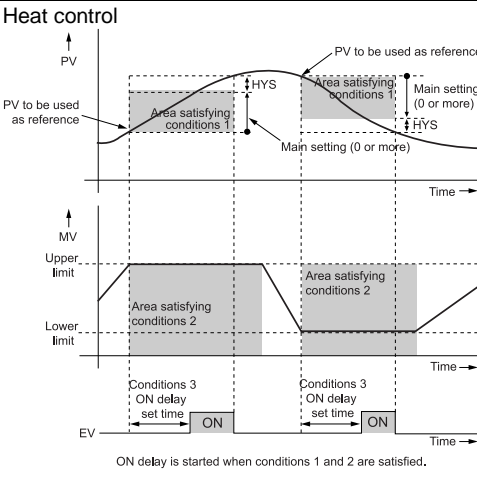
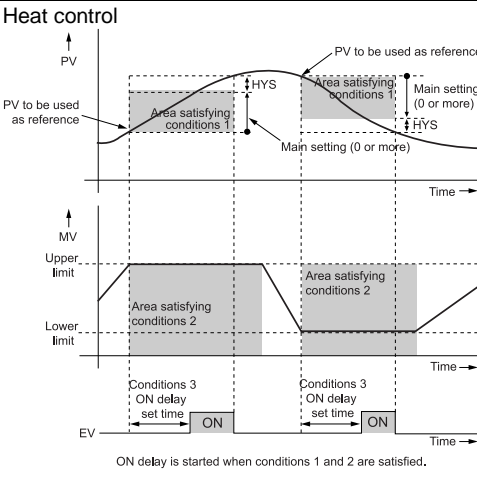
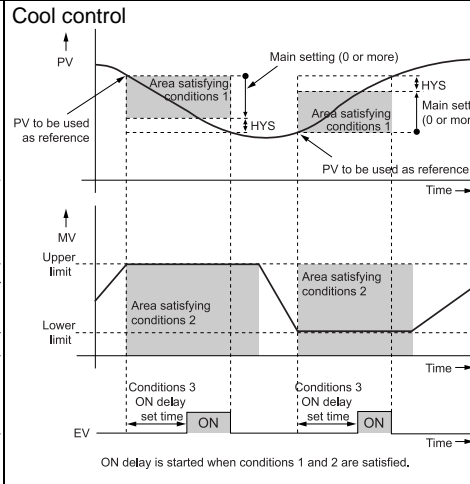
<p>Event</p>	<p>Event type</p>	<p style="text-align: center;">Loop diagnosis 3</p> <p>The event is turned ON when PV does not change corresponding to increase/decrease in MV (Manipulated variable). This event is used to detect any fault of final control devices.</p> <ul style="list-style-type: none"> Setting items <ul style="list-style-type: none"> Main setting: Change in PV from the point that the MV reaches the high limit (100%) or low limit (0%). Sub-setting: Range of absolute value of deviation (PV – SP) allowing the event to turn OFF. ON delay time: Diagnosis time OFF delay time: A period of time from power ON allowing the event to turn OFF. Operation specifications <ul style="list-style-type: none"> The direct action is used for the heat control. The event is turned ON when the increase in PV becomes smaller than the main setting after the diagnosis time (ON delay time) has elapsed from the time that the MV had reached the high limit, or when the decrease in PV becomes smaller than the main setting from the time that the diagnosis time (ON delay time) has elapsed from the time that the MV had reached the low limit. The reverse action is used for the cool control. The event is turned ON when the decrease in PV becomes smaller than the main setting after the diagnosis time (ON delay time) has elapsed from the time that the MV had reached the high limit, or when the increase in PV becomes smaller than the main setting after the diagnosis time (ON delay time) has elapsed from the time that the MV had reached the low limit. The event is turned OFF regardless of other conditions when the absolute value of the deviation (PV - SP) becomes less than the sub-setting. The event is turned OFF regardless of other conditions when a period of time after starting of operation from the time that the power has been turned ON becomes less than the OFF delay time. However, the event is turned OFF when the absolute value of the deviation is the (sub-setting – hysteresis) value or less after the absolute value of the deviation has become the sub-setting or more. CAUTION <ul style="list-style-type: none"> When setting the ON delay and OFF delay, it is necessary to put in "Multi-function setup". The default settings of the ON delay and OFF delay before shipment are 0.0s. 			
	<table border="1" style="width: 100%; border-collapse: collapse;"> <tr> <th style="width: 50%; text-align: center;">Direct action</th> <th style="width: 50%; text-align: center;">Reverse action</th> </tr> <tr> <td style="text-align: center;"> <p>Heat control</p>  </td> <td style="text-align: center;"> <p>Cool control</p>  </td> </tr> </table>		Direct action	Reverse action	<p>Heat control</p> 
Direct action	Reverse action				
<p>Heat control</p> 	<p>Cool control</p> 				
<p style="text-align: center;">PV alarm (status)</p> <table border="1" style="width: 100%; border-collapse: collapse;"> <tr> <th style="width: 50%; text-align: center;">Direct action</th> <th style="width: 50%; text-align: center;">Reverse action</th> </tr> <tr> <td>ON if PV alarm (alarm code AL01 to 03) occurs, OFF in other cases.</td> <td>OFF if PV alarm (alarm code AL01 to 03) occurs, ON in other cases.</td> </tr> </table>		Direct action	Reverse action	ON if PV alarm (alarm code AL01 to 03) occurs, OFF in other cases.	OFF if PV alarm (alarm code AL01 to 03) occurs, ON in other cases.
Direct action	Reverse action				
ON if PV alarm (alarm code AL01 to 03) occurs, OFF in other cases.	OFF if PV alarm (alarm code AL01 to 03) occurs, ON in other cases.				
<p style="text-align: center;">READY (status)</p> <table border="1" style="width: 100%; border-collapse: collapse;"> <tr> <th style="width: 50%; text-align: center;">Direct action</th> <th style="width: 50%; text-align: center;">Reverse action</th> </tr> <tr> <td>ON in the READY mode. OFF in the RUN mode.</td> <td>OFF in the READY mode. ON in the RUN mode.</td> </tr> </table>		Direct action	Reverse action	ON in the READY mode. OFF in the RUN mode.	OFF in the READY mode. ON in the RUN mode.
Direct action	Reverse action				
ON in the READY mode. OFF in the RUN mode.	OFF in the READY mode. ON in the RUN mode.				
<p style="text-align: center;">MANUAL (status)</p> <table border="1" style="width: 100%; border-collapse: collapse;"> <tr> <th style="width: 50%; text-align: center;">Direct action</th> <th style="width: 50%; text-align: center;">Reverse action</th> </tr> <tr> <td>ON in the MANUAL mode. OFF in the AUTO mode.</td> <td>OFF in the MANUAL mode. ON in AUTO mode.</td> </tr> </table>		Direct action	Reverse action	ON in the MANUAL mode. OFF in the AUTO mode.	OFF in the MANUAL mode. ON in AUTO mode.
Direct action	Reverse action				
ON in the MANUAL mode. OFF in the AUTO mode.	OFF in the MANUAL mode. ON in AUTO mode.				
<p style="text-align: center;">During AT (Auto tuning)</p> <table border="1" style="width: 100%; border-collapse: collapse;"> <tr> <th style="width: 50%; text-align: center;">Direct action</th> <th style="width: 50%; text-align: center;">Reverse action</th> </tr> <tr> <td>ON while AT is running. OFF while AT is being stopped.</td> <td>OFF while AT is running. ON while AT is being stopped.</td> </tr> </table>		Direct action	Reverse action	ON while AT is running. OFF while AT is being stopped.	OFF while AT is running. ON while AT is being stopped.
Direct action	Reverse action				
ON while AT is running. OFF while AT is being stopped.	OFF while AT is running. ON while AT is being stopped.				
<p style="text-align: center;">During SP ramp</p> <table border="1" style="width: 100%; border-collapse: collapse;"> <tr> <th style="width: 50%; text-align: center;">Direct action</th> <th style="width: 50%; text-align: center;">Reverse action</th> </tr> <tr> <td>ON during SP ramp. OFF when SP ramp is not performed or is completed.</td> <td>OFF during SP ramp. ON when SP ramp is not performed or is completed.</td> </tr> </table>		Direct action	Reverse action	ON during SP ramp. OFF when SP ramp is not performed or is completed.	OFF during SP ramp. ON when SP ramp is not performed or is completed.
Direct action	Reverse action				
ON during SP ramp. OFF when SP ramp is not performed or is completed.	OFF during SP ramp. ON when SP ramp is not performed or is completed.				

Event	Event type	Control operation (status)	
		Direct action	Reverse action
		ON during direct action (cooling). OFF during reverse action (heating).	OFF during direct action (cooling). ON during reverse action (heating).
		During motor position estimation (status)	
		Direct action	Reverse action
		ON during estimated position control. OFF in other cases.	OFF during estimated position control. ON in other cases.
		Timer (status)	
		<p>The direct and reverse action settings are disabled for the timer event. When using the timer event, it is necessary to set the operation type of the DI allocation to "Timer Start/Stop". Additionally, by setting the event channel of the DI allocation, multiple timer events are controlled from individual internal contacts (DI).</p> <ul style="list-style-type: none"> Setting items <ul style="list-style-type: none"> ON delay time: A period of time necessary to change the event from OFF to ON after DI has been changed from OFF to ON. OFF delay time: A period of time necessary to change the event from ON to OFF after DI has been changed from ON to OFF. Operation specifications <ul style="list-style-type: none"> The event is turned ON when DI ON continues for ON delay time or longer. The event is turned OFF when DI OFF continues for OFF delay time or longer. In other cases, the current status is continued. 	
		<ul style="list-style-type: none"> CAUTION When setting the ON delay and OFF delay, it is necessary to put in "Multi-function setup". The default settings of the ON delay and OFF delay before shipment are 0.0s. The default setting of the event channel of the DI allocation before shipment is "0". In this case, the timer event start/stop can be set for all internal events from one internal contact (DI). Additionally, as one or more event channel is set, the timer event start/stop can be set for one internal event specified by one internal contact (DI). Note that, for setting the event channel of the DI allocation, it is necessary to put in "Multi-function setup". 	
		Direct/Reverse action, standby, and READY operations can be set while each event (E1.C1 to E5.C2) is set up.	
		RSP (status)	
		Direct action	Reverse action
		ON in RSP mode. OFF in LSP mode.	OFF in RSP mode. ON in LSP mode.
		High/low limit of MFB (motor feedback) value	
Note: If main setting value > sub-setting value is set, Model R35/36 automatically interprets the set values of main setting and sub-setting the other way around.			
Differential gap	0 to 9999 digit		
Output operation	ON/OFF operation		
Output type	SPST relay contacts, Common for 3 points/independent contact for 2 points		
Output rating	250 V AC/30 V DC, 2 A (resistive load)		
Service life	100,000 cycles or more		
Min. switching specifications	5 V, 10 mA		
Communi- cation	Communication system	Communication protocol	RS-485
		Network	Multidrop, Connected as slave station, 1 to 31 units max.
		Data flow	Half-duplex
		Synchronization method	Start/stop synchronization
	Interface	Transmission system	Balance (differential) type
		Data line	Bit serial
		Communication lines	3 transmit/receive lines
		Transmission speed	4800, 9600, 19200, 38400 bps
		Communication distance	Max. 500 m
Protocol	RS-485 (3-wire type)		

Communi- cation	Message characters	Character configuration	9 to 12 bits/character				
		Data length	7 or 8 bits				
		Stop bit length	1 or 2 bits				
		Parity bit	Even parity, odd parity, or non-parity				
Current transformer input	Number of inputs	2 points					
	Detection function	Control output is ON.: Detection of heater line break or overcurrent Control output is OFF.: Detection of final control devices short-circuit					
	Input object	Current transformer with 800 turns Model QN206A (φ5.8 mm hole) Optional Model QN212A (φ12mm hole) Optional					
	Measurement current range	0.4 to 50 A					
	Indication accuracy	±5 %FS ± 1 digit					
	Indication range	0.0 to 70.0 A					
	Indication resolution	0.1 A					
	Output	Selected from control output 1 and control output 2, or event output 1, event output 2, and event output 3.					
	Min. detection time	Burnout detection: 0.3 or more min. for control output ON time. Final control device short-circuit detection: 0.3 s or more for min. control output OFF.					
	General specifications	Memory backup	Semiconductor non-volatile memory				
Operating power supply voltage		85 to 264 V AC, 50/60 Hz ± 2 Hz					
Power consumption		12 VA or less					
Insulation resistance		500 V DC, 10 MΩ or more between power supply terminal and secondary terminal					
Dielectric strength		1500 V AC for 1 min. between power supply terminal and secondary terminal					
Power ON inrush current		20 A or less					
Operating conditions		Ambient temperature	0 to 50 °C (0 to 40 °C for side-by-side mounting)				
		Ambient humidity	10 to 90 %RH (No condensation allowed)				
		Vibration resistance	0 to 2 m/s ² (10 to 60 Hz for 2 hrs. in each of X, Y, and Z directions)				
		Shock resistance	0 to 10 m/s ²				
		Mounting angle	Reference plane ±10°				
Transportation conditions		Ambient temperature	-20 to +70 °C				
		Ambient humidity	10 to 95 %RH (No condensation allowed)				
		Package drop test	Drop height: 60 cm (1 corner, 3 sides, 6 planes, free fall)				
Console and case material		Console: Polyester film Case: Modified PPE					
Case color		Light gray (DIC*650) * DIC (DIC Color Guide) is the color standard provided by DIC Corporation.					
Conformed standards		EN61010-1, EN61326-1					
Overvoltage category		Category II (IEC60364-4-433, IEC60664-1)					
Mounting		Panel mounting (with dedicated mounting bracket)					
Weight		Model R35: Approx. 250g (including dedicated mounting bracket) Model R36: Approx. 300g (including dedicated mounting bracket)					
Standard accessories	Part name	Part No.	Q'ty	Auxiliary parts/device (optional)	Part/Device name	Part/Model No.	Q'ty
	Mounting bracket	81409654-001	1 set		Mounting bracket	81409654-001	1 set
	Unit indication label	—	1		Current transformer	QN206A (φ5.8 mm hole)	1
					QN216A (φ12 mm hole)	1	
	Hard cover					81446915-001 (for R35)	1
						81446916-001 (for R36)	1
	Soft cover					81441121-001 (for R35)	1
						81441122-001 (for R36)	1
	Terminal cover					81446912-001 (for R35)	1
						81446913-001 (for R36)	1

Input Types and Ranges

Input type	C01 No.	Sensor type	Range (°C)	Range (°F)
RTD	41	Pt100	-200.0 to +500.0	-300 to +900
	42	JPt100	-200.0 to +500.0	-300 to +900
	43	Pt100	-200.0 to +200.0	-300 to +400
	44	JPt100	-200.0 to +200.0	-300 to +400
	47	Pt100	-100.0 to +200.0	-150 to +400
	48	JPt100	-100.0 to +200.0	-150 to +400
	49	Pt100	-100.0 to +150.0	-150 to +300
	50	JPt100	-100.0 to +150.0	-150 to +300
	51	Pt100	-50.0 to +200.0	-50 to +400
	52	JPt100	-50.0 to +200.0	-50 to +400
	53	Pt100	-50.0 to +100.0	-50 to +200
	54	JPt100	-50.0 to +100.0	-50 to +200
	55	Pt100	-60.0 to +40.0	-60 to +100
	56	JPt100	-60.0 to +40.0	-60 to +100
	57	Pt100	-40.0 to +60.0	-40 to +140
	58	JPt100	-40.0 to +60.0	-40 to +140
	59	Pt100	-10.00 to +60.00	-10 to +140
	60	JPt100	-10.00 to +60.00	-10 to +140
	61	Pt100	0.0 to 100.0	0 to 200
	62	JPt100	0.0 to 100.0	0 to 200
	63	Pt100	0.0 to 200.0	0 to 400
	64	JPt100	0.0 to 200.0	0 to 400
	67	Pt100	0.0 to 500.0	0 to 900
	68	JPt100	0.0 to 500.0	0 to 900

Input type	C01 No.	Sensor type	Range
Linear input	81	0 to 10 mV	Scaling between -1999 and +9999. Decimal point position changeable.
	82	-10 to +10 mV	
	83	0 to 100 mV	
	86	1 to 5 V	
	87	0 to 5 V	
	88	0 to 10 V	
	89	0 to 20 mA	
	90	4 to 20 mA	

Conformed standards for input sensors

RTD Pt100: JIS C 1604-1997
JPt100: JIS C 1604-1989

* JIS: Japanese Industrial Standards

Handling Precautions

- Though the accuracy is $\pm 0.1\%FS \pm 1$ digit, the accuracy varies according to the range.
The accuracy of the No. 55 to 62 and 81 is $\pm 0.15\%FS$ for each range.
- For ranges with a decimal point, digit(s) after the decimal point is (are) displayed as well.

Model Selection Guide

I II III IV V VI VII VIII Example: R35TR0UA1000

I	II	III	IV	V	VI	VII	VIII	Specifications	Remarks	
Basic model No.	Mount-ing	Control output	PV input	Power supply	Option 1	Option 2	Additional processing			
R35								Single Loop Controller with Mask size 48mm x 96mm		
R36								Single Loop Controller with Mask size 96mm x 96mm		
	T							Panel mounting type		
								Control output 1	Control output 2	
		R0						Relay contact output (N.O.)	Relay contact output (N.C.)	
		R1						Relay contact output for motor drive (open side)	Relay contact output for motor drive (close side)	With MFB
		C0						Current output	None	
		CC						Current output	Current output	
			U					Universal		
				A				Power: 100 to 240 V AC, 50/60Hz		
					1			Event relay output: 3 points		
					2			Event relay output: 3 points, Auxiliary output (current output)		
					4			Event relay output: 2 points (independent contact)		
					5			Event relay output: 2 points (independent contact), Auxiliary output (current output)		
					0			None		
					(Notes 1, 2) 1			Current transformer inputs: 2 points, Digital inputs: 4 points		
					(Notes 1, 2) 2			Current transformer inputs: 2 points, Digital inputs: 4 points, RS-485 communication		
					(Notes 1, 2) 3			Current transformer inputs: 2 points, Digital inputs: 2 points, RSP input		
					(Notes 1, 2) 4			Current transformer inputs: 2 points, Digital inputs: 2 points, RSP input, RS-485 communication		
						00		No additional processing		
						D0		Inspection Certificate provided		
						Y0		Complying with the traceability certification		

Note 1. Current transformer is optional (sold separately).

Note 2. When the control output is motor drive relay (Model R35TR1/R36TR1), the current transformer input is not applied. MFB input is applied.

Dimensions

Model R35

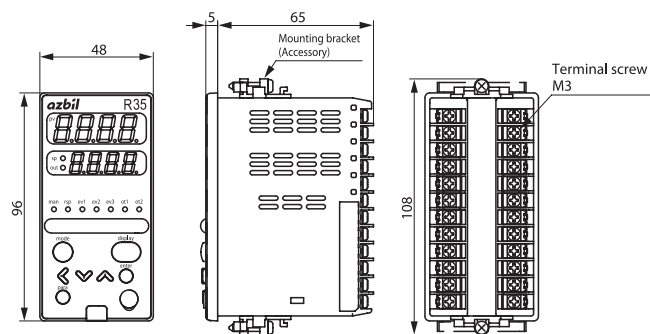

Model R36

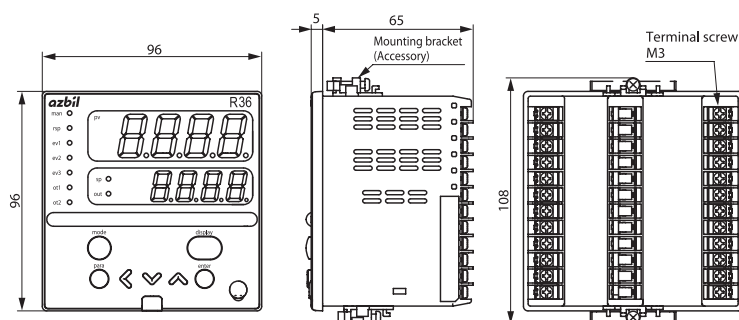

Handling Precautions

Tighten the screws of the mounting bracket (accessory). When the mounting bracket is secured firmly so that no play exists, tighten the screws further by one turn to fix the bracket to the panel. If the screws are tightened excessively, this may cause the case to deform.

Panel cutout diagram

Model R35

Individual mounting

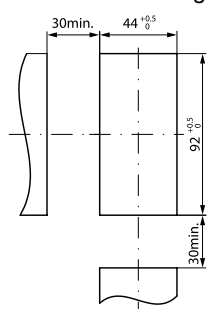

Side-by-side mounting

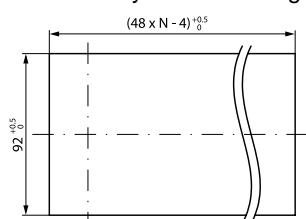

Model R36

Individual mounting

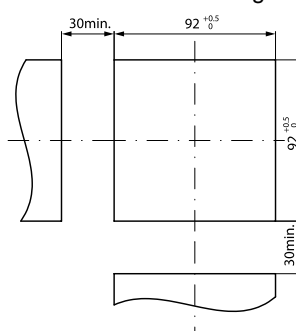

Side-by-side mounting

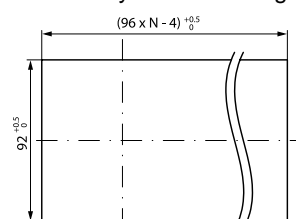

Handling Precautions

- When mounting three or more units of Model R35/R36 tightly in the horizontal direction, pay special attention so that the ambient temperature does not exceed 40 °C.

Part Names and Functions

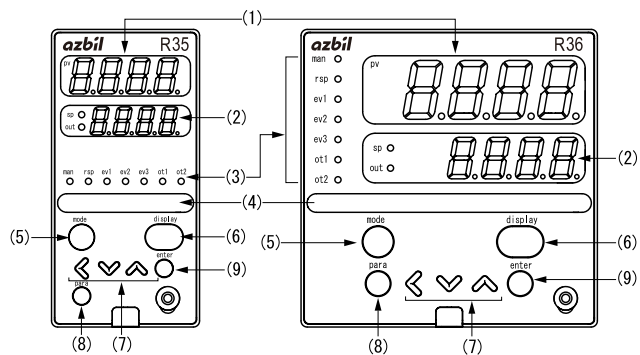

- (1) Display 1: Displays PV values (present temperature, etc.) or setting items.
- (2) Display 2: Displays SP values (set temperature, etc.) or the set value of each setting item. When the display 2 shows the SP value, the "sp" lamp lights up. When the display 2 shows the manipulated variable (MV), the "out" lamp lights up.

- (3) Mode indicators
 - man: Lights in MANUAL mode (manual operation mode).
 - rsp: Lights in RSP mode (remote setup input mode).
 - ev1 to ev3: Light when event relay output is ON
 - ot1, ot2: Light when control output is ON.

- (4) Multi-status indicator: Priority lighting condition and lighting status are combined in a group, and 3 groups can be set.
- (5) [mode] key: Performs the preset operation when being pressed for 1 s or longer.
- (6) [display] key: Changes the display contents in the operation display mode. Also changes the bank setup display back to the operation display.
- (7) <math>\lt; <math>\vee<math>, \wedge$$ keys: Increase/decrease numeric values, or shift digits.
- (8) [para] key: Switches the display.
- (9) [enter] key: Starts to change setting values and fixes the entered values to change.

Terminal Connection Diagram

Wiring of Model R35/R36

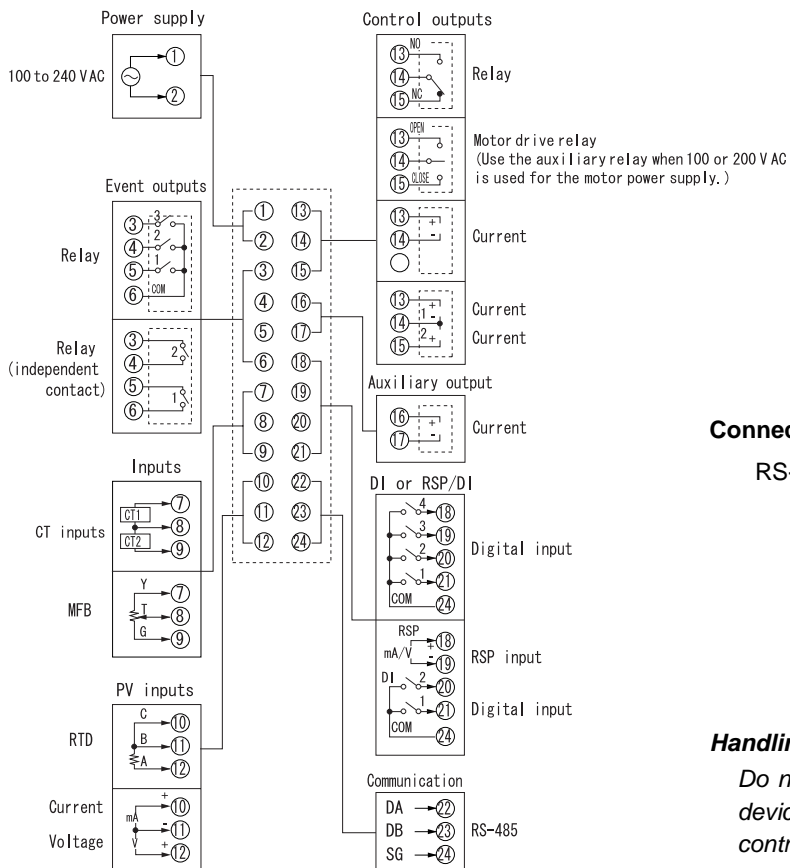

Connection of RS-485 communication

RS-485 is a 3-wire connection.

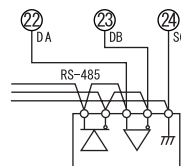

Example: Connection with 5-wire instrument

Handling Precautions

Do not connect any external terminating resistor since a device similar to the terminating resistor is built-into this controller.

Precautions on the Use of Self-tuning Function

The final control devices must be turned on simultaneously with or prior to this product when the self-tuning function is to be used.

Precautions on Wiring

1. Internal isolation

Solid line portions "———" are isolated.
Dotted line portions "-----" are not isolated.

Power supply		Internal circuit	Control output 1		
PV input			Control output 2		
CT input 1			Auxiliary output		
CT input 2			Event output 1	Event output 1 (Independent output)	
MFB input				Event output 2 (Independent output)	
Digital input 1	Digital input 1	Event output 3			
Digital input 2	Digital input 2				
Digital input 3	RS-485 Communication				
Digital input 4	RS-485 Communication				
RSP input					

Notes:

- * Availability of input and output is based on a model.
- * For independent contacts, event outputs 1 and 2 are isolated.

2. Preventive measures against noise for power supply

(1) Reduction of noise

Even though the noise is small, the noise filter is used to eliminate the effect of the noise as much as possible.

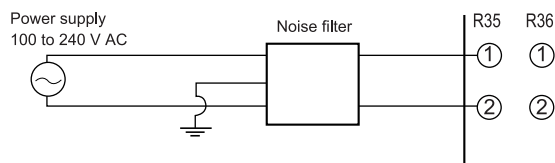

(2) Protection from large noise

If a large amount of noise exists, use appropriate isolation transformer and line filter to eliminate the effect of the noise.

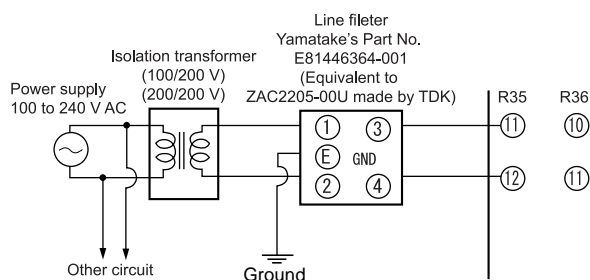

3. Noise sources in the installation environment and preventive measures

Generally, the following may be the noise sources in the installation environment:

Relay and contact, electromagnetic coil, solenoid valve, power supply line (particularly, 100 V AC or more), motor commutator, phase angle control SCR, radio communication device, welding machine, high-voltage ignitor, etc.

Preventive measures against fast rise noise

Use of CR filter is effective to prevent fast rise noise.

Recommended filter:

Yamatake's Part No. **81446365-001**

(Equivalent to 953M500333311 made by Matsuo Electric.)

4. Wiring precautions

- (1) After taking the noise preventive measures, do not bundle the primary and secondary power cables together or put both power cables in the same conduit or duct.
- (2) Keep the input/output and communication lines 50 cm or more away from the power lines and power supply lines having a voltage of 100 V AC or more. Additionally, do not put these lines together in the same conduit or duct.

5. Inspection after wiring

After the wiring work has been completed, always inspect and check the wiring status. Great care should be taken since incorrect wiring may cause the product to malfunction or severe personal injury.

 CAUTION

This product has been designed, developed and manufactured for general-purpose application in machinery and equipment. Accordingly, when used in the applications outlined below, special care should be taken to implement a fail-safe and/or redundant design concept as well as a periodic maintenance program.

- Safety devices for plant worker protection
- Start/stop control devices for transportation and material handling machines
- Aeronautical/aerospace machines
- Control devices for nuclear reactors

Never use this product in applications where human safety may be put at risk.

Install this product in the following locations.

- Common mode voltage for I/O excluding the power supply and relay contact output must satisfy the following.
Voltage between the product and the ground: 33 V r.m.s. or less, 46.7 V peak or less
- Not high or low temperature/humidity.
- Free from sulfide gas or corrosive gas.
- Less dust or soot.
- Appropriately protected locations from direct sunlight, wind or rain.
- Less mechanical vibration and shock.
- Not close to the high voltage line, to welding machine or to electrical noise generating source.
- Minimum of 15 m away from the high voltage ignition device for a boiler.
- Less effect by magnetic.
- No flammable liquid or gas.



Specifications are subject to change without notice.

Yamatake Corporation
Building Systems Company

<http://www.yamatake.com>