

# CO<sub>2</sub> Stat

## Room CO<sub>2</sub> Concentration Controller

### Model CY7101

#### General

The Room CO<sub>2</sub> Concentration Controller (CO<sub>2</sub> Stat) opens and closes contacts in accordance with the CO<sub>2</sub> concentration level in a room. CO<sub>2</sub> Stat is suitable for properly controlling indoor air quality while conserving energy. It also has a function for outputting voltage signals consistent with the CO<sub>2</sub> concentration.

#### Features

- 1) Employs a solid electrolyte element
- 2) Compact, lightweight, and inexpensive
- 3) Suitable for on-off command to ventilation equipment as CO<sub>2</sub> Stat provides contact output in response to the CO<sub>2</sub>-concentration setting (800 ppm or 1000 ppm).
- 4) Can be used as a measurement signal for CO<sub>2</sub> concentration monitoring with the auxiliary-voltage output (atmospheric CO<sub>2</sub> concentration of approx. 400 ppm to 2000 ppm), proportional to the CO<sub>2</sub> concentration.
- 5) Calibrates automatically with the microcomputer so that the periodic calibration is not required.

#### Specifications

Items	Specifications
Sensing range	Atmospheric CO <sub>2</sub> concentration (approx. 400 ppm to 2000 ppm)
Sensing element	Solid electrolyte
Response speed	90 sec (at 90 % response)
Operating environmental conditions	0 °C to 50 °C 5 % to 70 %RH (Non-condensing)
Transport/storage conditions	-20 °C to 60 °C 5 % to 90 %RH (in a moisture-proof package)
Contact output	Potential free contact output (SPST switch, 24 V AC, 1 A) ON setting for 800 or 1000 ppm (changeable) Contact differential: approx. 100 ppm.
Auxiliary-voltage output	1 to 5 V DC (0 to 2000 ppm, linear)
Power supply voltage	24 V AC +10 %, -15 %, 50/60 Hz
Power consumption	1.4 VA or less
Initial output	Enters initial mode for 8 hours after energization (Contact output: OFF; voltage output: 1.8 V {maintains 400 ppm}) After the 8 hours, contact output and auxiliary-voltage output are started. *1
Output impedance	100 Ω
Insulation resistance	500 MΩ or more at 500 V DC



Items	Specifications
Withstand voltage	500 V AC with 1 mA or less/min. of leakage current
Weight	Approx. 100 g
Wiring	6 wires (2 wires each of power supply, concentration output, and relay contact output), 18 AWG stranded wire of 0.75 mm <sup>2</sup> cross section, approx. 30 cm long (from board)
Finish	Cover: PC resin, pale gray (JPMA*2 BN-85 (2003 edition)) Base: Pale gray (JPMA BN-85 (2003 edition))
Accessories	4 main unit mounting screws (M3 × 16)
Parts that require separate order	Wall-direct mounting kit (Part No. 83165803-001) Applicable to mounting directly on a wall  

\*1 After the CO<sub>2</sub> Stat is energized, eight hours are normally required for the element to stabilize. During this period, CO<sub>2</sub> Stat provides the outputs specified in Specifications as initial mode outputs.

\*2 JPMA stands for Japan Paint Manufactures Association.

## Models

Model numbers	Specifications
CY7101A1000	Room CO <sub>2</sub> concentration controller (CO <sub>2</sub> Stat), with company logo
CY7101A1000-1	Room CO <sub>2</sub> concentration controller (CO <sub>2</sub> Stat), without company logo

## How the CO<sub>2</sub> Stat Works

This product adopts solid electrolyte for a sensing element composed of solid electrolyte, carbonate, and electrode. The carbonate maintains an equilibrium with the atmospheric CO<sub>2</sub> gas. If a change occurs in the atmospheric CO<sub>2</sub> concentration, the balance is lost, which is interpreted as a change in the electromotive force.

## Safety Instructions

Please read instructions carefully and use the product as specified in this manual. Be sure to keep this manual nearby for ready reference.

### Usage Restrictions

This product is targeted for general air conditioning. Do not use this product in a situation where human life may be affected. If this product is used in a clean room or a place where reliability or control accuracy is particularly required, please contact Yamatake's sales representatives. Yamatake Corporation will not bear any responsibilities for the results produced by the operators.

### WARNING



- DANGER: To prevent the risk of severe or fatal electrical shock, always disconnect power source and product power supply before performing any wiring.



- Do not disassemble at any time except when removing the cover to wire or when replacing a part. Equipment damages or electrical shock may occur.



- Make sure all the wires are tightly connected to prevent heat generation or equipment damages.



- Use terminal lugs with insulating sleeves for terminal connections.



- Regarding the operating conditions,
  - in a space where the air conditioning runs for 24 hours a day or where CO<sub>2</sub> is always produced with the high CO<sub>2</sub> concentration, the accuracy is not guaranteed. Do not use the product under such conditions.
  - in a space where fresh air is always required or more fresh air than usual is required due to hard work intensity, it is dangerous to control fresh air (outdoor air) intake. Do not control fresh air (outdoor air) intake using CO<sub>2</sub> measuring instruments including this product under such conditions.

### CAUTION



- Installation must be performed by qualified personnel in accordance with all applicable safety standards.



- This product must be operated within its operating ranges specified in this manual. Failure to comply will cause equipment damages.



- Installation must be carried out in accordance with the operating conditions specified in this manual to prevent equipment damages.



- All wiring must comply with local codes of indoor wiring and electric installation rules.



- Do not incinerate this product for waste disposal. Do not recycle all or a part of this product, either.



- Dispose of this product as an industrial waste complying with the local regulations.

**Dimensions (mm)**

**1. Dimensions of the CO<sub>2</sub> Stat main unit with Wall-direct mounting kit**

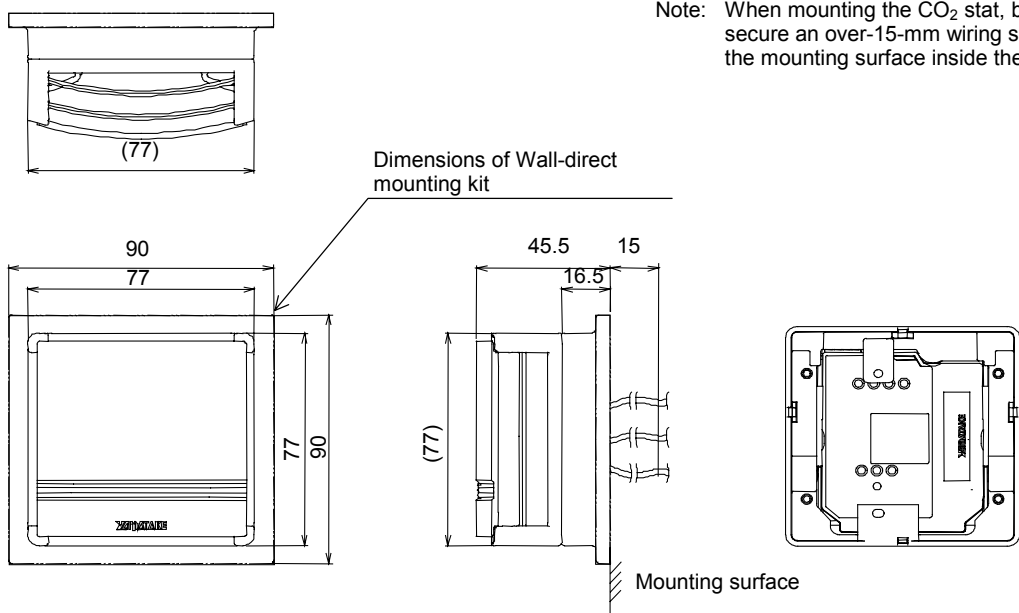

**(Surface view of mounting plate)**

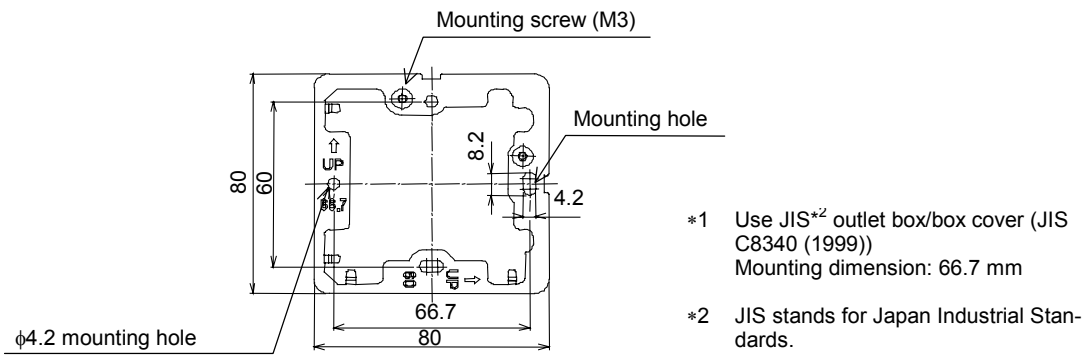

Figure 1. Dimensional diagram

## Installation

### Installation requirements

- 1) Mount CO<sub>2</sub> Stat on a wall approx. 1.5 m high above the floor.
- 2) Avoid locations where air circulation is interfered by furniture or a door and where heat from office automation equipment stays on.
- 3) Choose an installation location with no vibration.
- 4) Do not install CO<sub>2</sub> Stat where it may be affected by dripping water.
- 5) Do not allow dew condensation on the CO<sub>2</sub> Stat main unit.
- 6) Do not install CO<sub>2</sub> Stat directly on the wall without Wall-direct mounting kit.
- 7) Do not install the CO<sub>2</sub> Stat near a temperature/humidity instrument, such as a sensor, thermostat, etc.
- 8) Do not install the CO<sub>2</sub> Stat in the Multi-thermocase.

### Installation procedure: Neostat directly on a wall (See Fig. 2.)

- 1) Attach the mounting plate to the box cover (outlet box mounting dimension: 66.7 mm (JIS\* C8340:1999)) located inside the wall.  
\* JIS stands for Japan Industrial Standards.
- 2) Install the main part of the Wall-direct mounting kit on the mounting plate. (See Fig. 6.)
- 3) Open the moisture-proof aluminum package to unpack the CO<sub>2</sub> Stat.

#### IMPORTANT:

Open the moisture-proof aluminum package right before installing the CO<sub>2</sub> Stat.

- 4) To make the settings for contact output, remove the cover from the CO<sub>2</sub> Stat main unit and change the setting of jumper switch 1. (See Table 1 and Fig. 3.)
- 5) Connect the output lead wires of the CO<sub>2</sub> Stat main unit to the external wires (for the load side). (See Table 2 and Fig. 4.)
- 6) Remove the cover from the CO<sub>2</sub> Stat main unit, and mount the main unit on the main part of the Wall-direct mounting kit with the 4 main-unit mounting screws (M3 × 16).
- 7) Place the cover back on the CO<sub>2</sub> Stat main unit to complete the installation procedure. (See Fig. 5.)

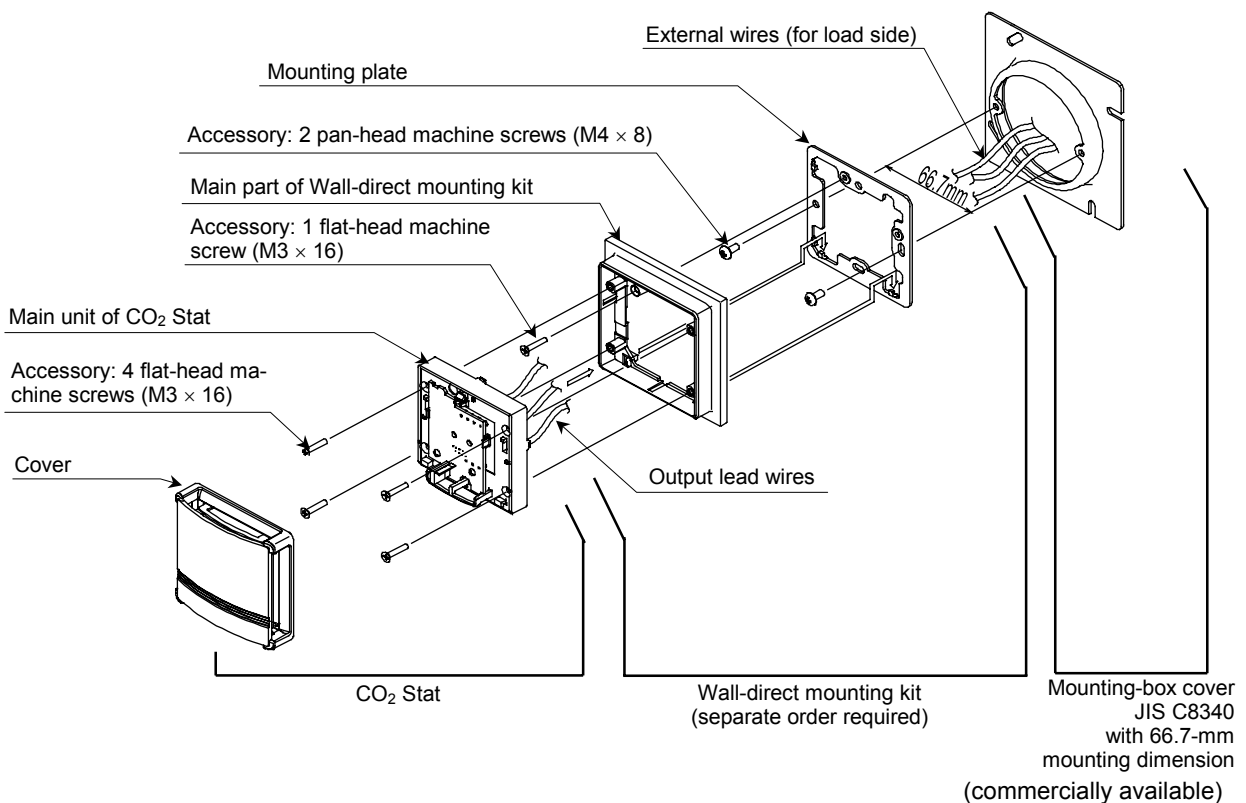

Figure 2. Installation procedure: CO<sub>2</sub> Stat with Wall-direct mounting kit

Table 1. Jumper switch setting

Jumper switch 1 (JP1)	Common-1: 1000 ppm setting
	Common-2: 800 ppm setting
Jumper switch 2 (JP2)	

**IMPORTANT:**  
Do not change the factory preset of Jumper switch 2.

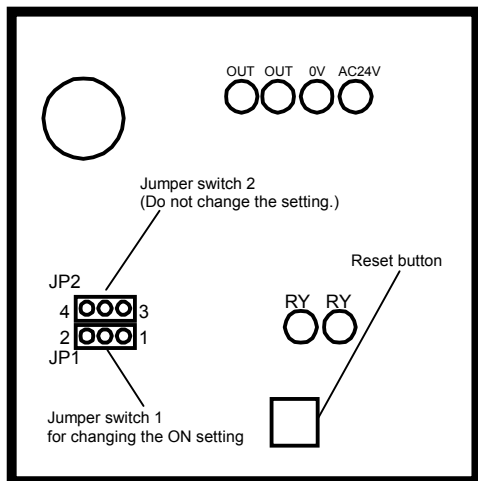
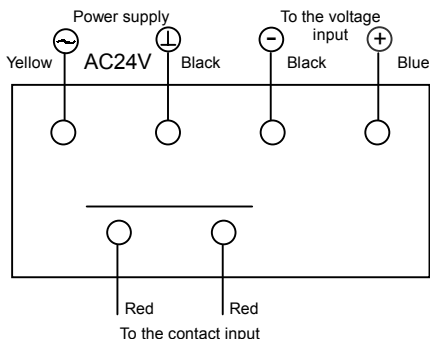

Figure 3. Jumper switches and reset button

Table 2. Wire connections

Wire colors (in the order of left to right terminals viewed from the main unit rear side)		Items
Upper line	Yellow	Power supply: 24 V AC
	Black	Power supply: 0 V AC
	Black	Output (-): Common
	Blue	Output (+): 1 to 5 V DC
Lower line	Red	Potential free contact output
	Red	Potential free contact output



\* Rear view of the CO<sub>2</sub> Stat main unit

Figure 4. Wire connection diagram

**Removing or installing the cover**

- Removing the cover  
Remove the cover by pressing the spring, using a thin stick, located inside the top section of the CO<sub>2</sub> Stat main unit.
- Installing the cover  
Insert the two cover tabs into the two mounting holes located at the bottom of the main unit and fix the cover in place using the spring located at the top of the main unit.

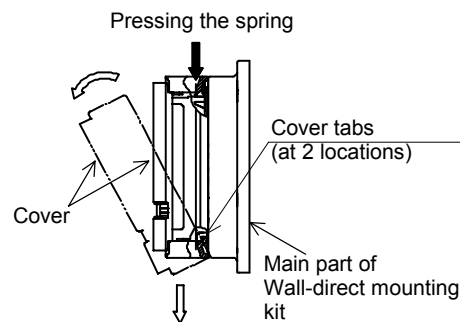

Figure 5. Removing and installing the cover

**Installing the main part of Wall-direct mounting kit**

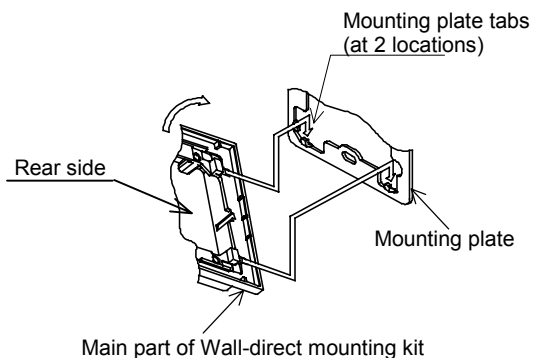

Figure 6. Installing the main part of the Wall-direct mounting kit

## Use of Individual AC Transformer

**⚠ CAUTION**

**!** Use an insulated transformer to supply 24 V AC power supply voltage. Never share the 24 V AC power supply with other equipment (except ICC). If a transformer is shared, a loop will be formed at common and the transmitter may be damaged.

- Shared transformer (24 V AC power supply)

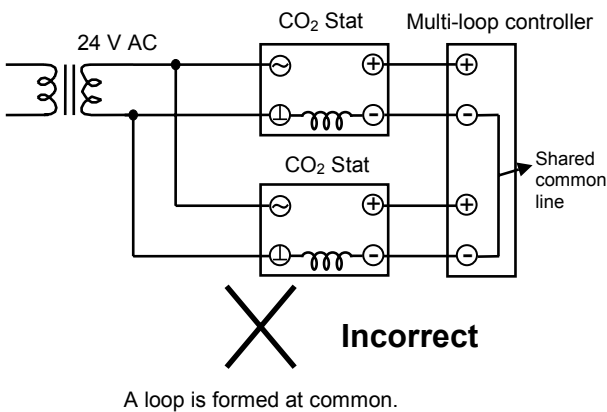

Figure 7. Shared transformer

- Separate transformer (24 V AC power supply)

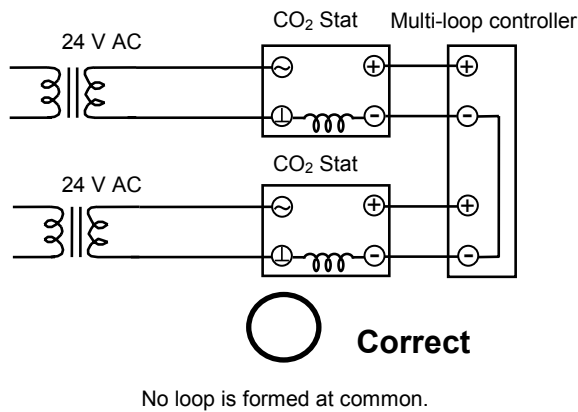

Figure 8. Separate transformer

If a third party device is connected to the CO<sub>2</sub> stat, an induction current may flow from the transmitter to the input circuit of the receiving device, or noise may be produced due to an inadequate time constant of the receiving device. Therefore, confirm that the following actions are taken:

- Use a controller with a low pass filter (removal rate of 40dB or higher in normal mode) for receiving signals.
- Connect an isolator to the input of the receiving device if the removal ratio is unknown.
- No problem will occur for connecting with Yamatake's controllers.

## Operation check

- 1) The CO<sub>2</sub> Stat enters initial mode for 8 hours after being energized. Make sure the contact output is OFF and the auxiliary-voltage output is 1.8 V.
- 2) When the CO<sub>2</sub> stat has been energized for 8 hours, breathe on the CO<sub>2</sub> Stat to confirm that the contact output comes ON and that the auxiliary-voltage output increases.
- 3) If the CO<sub>2</sub> Stat is not judged to be normal as a result of the above operation check, press the reset button (Fig. 3) on the board. (Note that the accuracy is not guaranteed for 24 hours if the reset button is pressed in an atmosphere with a high CO<sub>2</sub> concentration.) Forced calibration is performed when the reset button is pressed.

## Calibration

No periodic calibration is required. The reference-value updating program\* of the built-in microcomputer corrects drift of the element.

\* The lowest CO<sub>2</sub> concentration peak of the day is updated to 400 ppm.

**IMPORTANT:**

- Due to the calibration described above, in a space where the air conditioning runs 24 hours a day or where the CO<sub>2</sub> concentration is high (with the presence of many people around the clock), the accuracy is not guaranteed.
- Startup characteristics: If the CO<sub>2</sub> Stat is placed and left unenergized under the condition of high temperature and high humidity for an extended period, two or three weeks may be required for the CO<sub>2</sub> Stat to stabilize after it is energized.



*Specifications are subject to change without notice.*

**YAMATAKE**

---

**Yamatake Corporation**  
**Building Systems Company**

Tamachi Kiyota Building  
4-3-4, Shibaura  
Minato-ku, Tokyo 108-0023  
<http://www.yamatake.com>

Rev.1.0 Sep. 2004

AB-6481 0.5H-H(W)