

Three-Way Mixing Valve with Flanged-End Connection

Model V5065A

General

Model V5065A is a series of three-way mixing valves with flanged-end connection. The valve body is cast-iron, and the valve size ranges from DN25 to DN150.

Combined with the control motor (Model MY3000 series), a high-torque actuator (Models MY9402, MY9403), or a pneumatic actuator (Models MP912, MP953), Model V5065A controls non-corrosive chilled/hot water.

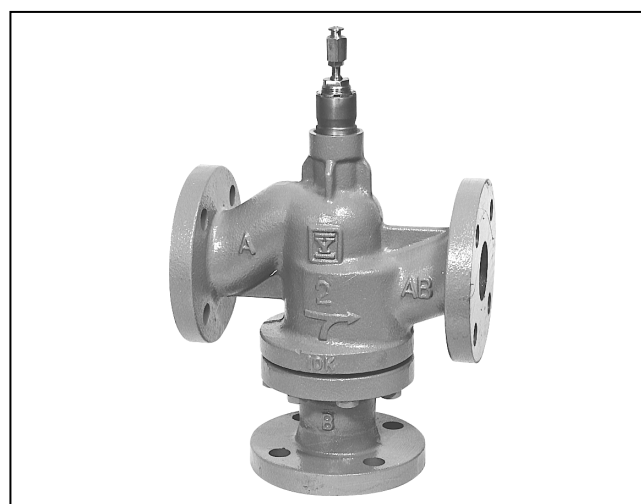

Specifications

Item	Specification					
Models	Three-way mixing valve with flanged-end connection					
Model number	Valve size mm	Port size (in.)	Flow capacity Cv	Rated lift mm	Weight kg	
V5065A6001	25 × 20 (1 × 3/4)		6.3	19	8.6	
V5065A6019	25 × 25 (1 × 1)		11		8.7	
V5065A6027	40 × 32 (1 1/2 × 1 1/4)		18		13.6	
V5065A6035	40 × 40 (1 1/2 × 1 1/2)		28		13.5	
V5065A6043	50 × 50 (2 × 2)		50		19	
V5065A6050	65 × 65 (2 1/2 × 2 1/2)		72		26	
V5065A6068	80 × 80 (3 × 3)		102		33.5	
V5065A6076	100 × 100 (4 × 4)		188		38	50
V5065A6084	125 × 125 (5 × 5)		280		69	
V5065A6092	150 × 150 (6 × 6)		360		101.4	
Close-off ratings	Refer to Table 1 and Figs. 1 to 4.					
Materials	Body: Cast iron (JIS*1 FC200) Plug, seat: Stainless steel (JIS SCS13) Stem: Stainless steel (JIS SUS304) Packing, gasket: Non asbestos					
Body pressure rating	1 MPa					
Allowable fluid temperature	0 °C to 200 °C*2					

Item	Specification		
Allowable temperature difference	Max. 70 °C (between ports)		
End connection	Flanged-end connection with flat face flange (JIS 10K)		
Flow characteristic	Linear		
Plug shape	V-port mixed plug		
Applicable actuators	Control motor: Model MY3000 with valve linkage Model Q455 High-torque actuators: Models MY9402 and MY9403 with yoke assembly Model QMY9400 Pneumatic actuators: Models MP912, MP953		
Standard replacement parts	(Separate order is required for a replacement part.)		
Part name	Part number	Applicable valve size mm (in.)	Description
Stem button	228895	25 to 80 (1 to 3)	M8 threaded (1 mm pitch)
	221867	100 to 150 (4 to 6)	M10 threaded (1.25 mm pitch)
Packing set	83164120-001	25, 40 (1, 1 1/2)	For φ8 mm stem
	83164120-002	50 to 100 (2 to 4)	For φ10 mm stem
	83164120-003	125, 150 (5, 6)	For φ13 mm stem
Requirements for ordering	1. Valve model number 2. Actuator and valve linkage/yoke model numbers (if necessary)		

Notes:

*1. JIS: Japanese Industrial Standards

*2. Due to heat transmission, etc., an actuator operating the valve may not accept this range. Refer to Specifications/Instructions of your actuator.

Safety Instructions

Please read instructions carefully and use the product as specified in this manual. Be sure to keep this manual near by for ready reference.

Usage Restrictions

This product is targeted for general air conditioning. Do not use this product in a situation where human life may be affected. If this product is used in a clean room or a place where reliability or control accuracy is particularly required, please contact Yamatake's sales representative. Yamatake Corporation will not bear any responsibility for the results produced by the operators.

WARNING



- This product may weigh 18 kg or over depending on the model number. To move or carry the product, use a vehicle or provide enough manpower. Severe injury or product damage may be caused by carelessly handling or dropping the product.



- Do not disassemble the product combined with the actuator at any time. Electrical shock or equipment failure may result.



- Do not touch the installed valve. When being used to control hot water, the valve reaches high temperature and may result in burn injury.

CAUTION



- Installation and wiring must be performed by qualified personnel in accordance with all applicable safety standards.



- Installation must be carried out according to the operating conditions (temperature, humidity, power, vibration, shock, installation position, atmospheric conditions, etc.) specified in this manual to prevent equipment damages.



- This product must be operated within its operating ranges specified in this manual. Failure to comply will cause equipment damages.



- Avoid any application that keeps the product operating cycle excessively frequent so as not to shorten the product service life.



- Install the product in the direction and position specified in this manual. Excessively tight connection to the piping and improper installation position may damage the valve body.



- After piping installation, make sure no fluid leaks from the connecting parts.



- Do not allow any foreign substance inside the piping. After the piping installation, flush the piping so that no foreign substance remains there.



- Do not leave the controlled fluid frozen. Frozen fluid may cause valve damage or fluid leakage.



- Dispose of this product as an industrial waste in accordance with your local regulations. Do not recycle all or part of this product.

Close-Off Ratings: Model V5065A Combined with an Electric Actuator

Table 1. Close-off ratings (kPa): Model V5065A combined with an electric actuator

Valve size × Port size mm (in.)	Actuator combined with valve Cv	Control motor Model MY3000			High torque actuator	
		with valve linkage Model Q455C*	with valve linkage Model Q455D*	with valve linkage Model Q455F*	Model MY9402	Model MY9403
					with yoke assembly Model QMY9400A	with yoke assembly Model QMY9400B
25 × 20 (1 × 3/4)	6.3	980		539	980	
25 × 25 (1 × 1)	11	980		539	980	
40 × 32 (1 1/2 × 1 1/4)	18	470		225	902	
40 × 40 (1 1/2 × 1 1/2)	28	470		225	902	
50 × 50 (2 × 2)	50	314		137	578	
65 × 65 (2 1/2 × 2 1/2)	72	186		85	353	
80 × 80 (3 × 3)	102	127		56	235	
100 × 100 (4 × 4)	188		82			142
125 × 125 (5 × 5)	280		47			98
150 × 150 (6 × 6)	360		33			69

*Note:

Refer to Specifications/Instructions manual of Model Q455 for appropriate combinations of the control motor Model MY3000 and valve linkage.

Close-Off Ratings: Model V5065A Combined with a Pneumatic Actuator

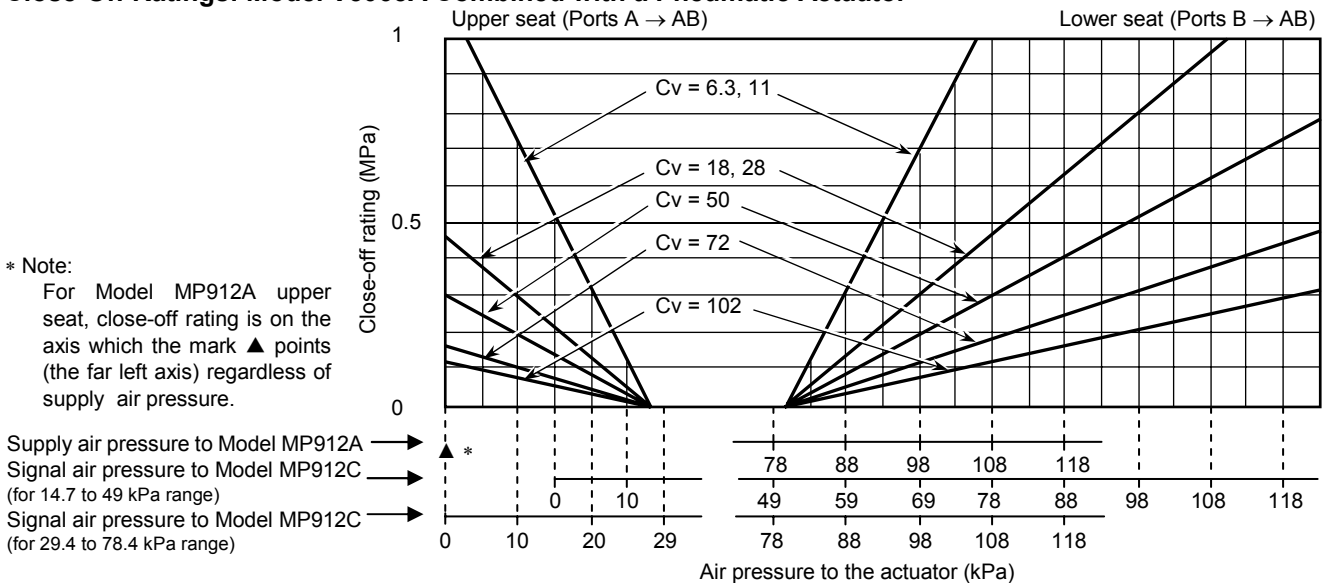

Figure 1. Close-off ratings: Model V5065A combined with Model MP912A or MP912C (direct action)

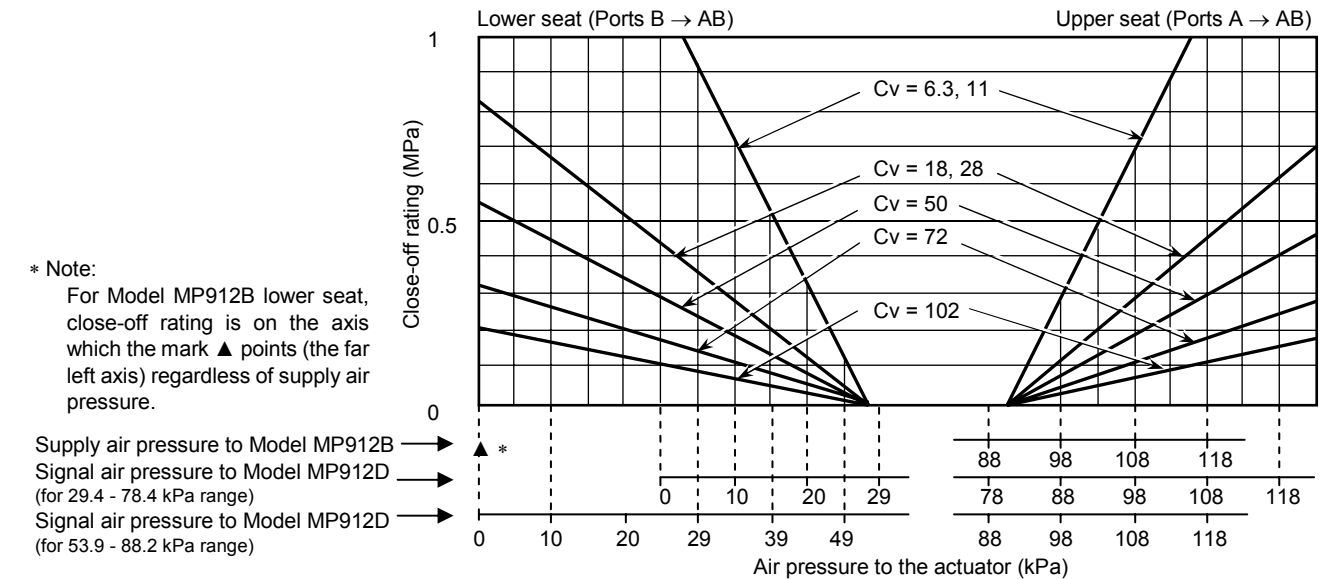

Figure 2. Close-off ratings: Model V5065A combined with Model MP912B or MP912D (reverse action)

* Note:

For Model MP953E upper seat, close-off rating is on the axis which the mark ▲ points (the far left axis) regardless of supply air pressure.

Supply air pressure to Model MP953E →

Signal air pressure to Model MP953C →

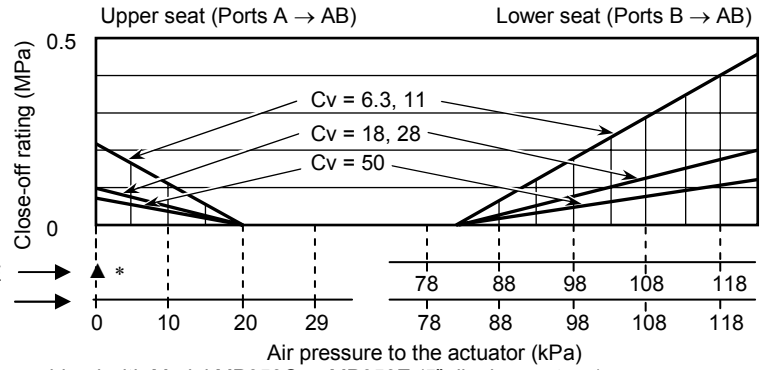

Figure 3. Close-off ratings: Model V5065A combined with Model MP953C or MP953E (5" diaphragm type)

Upper seat (Ports A → AB)

Cv	Close-off rating (kPa)
188	176
280	108
360	78

Close-off ratings are as shown in the table above regardless of supply air pressure.

Lower seat (Ports B → AB)

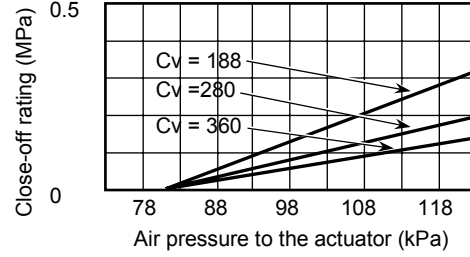
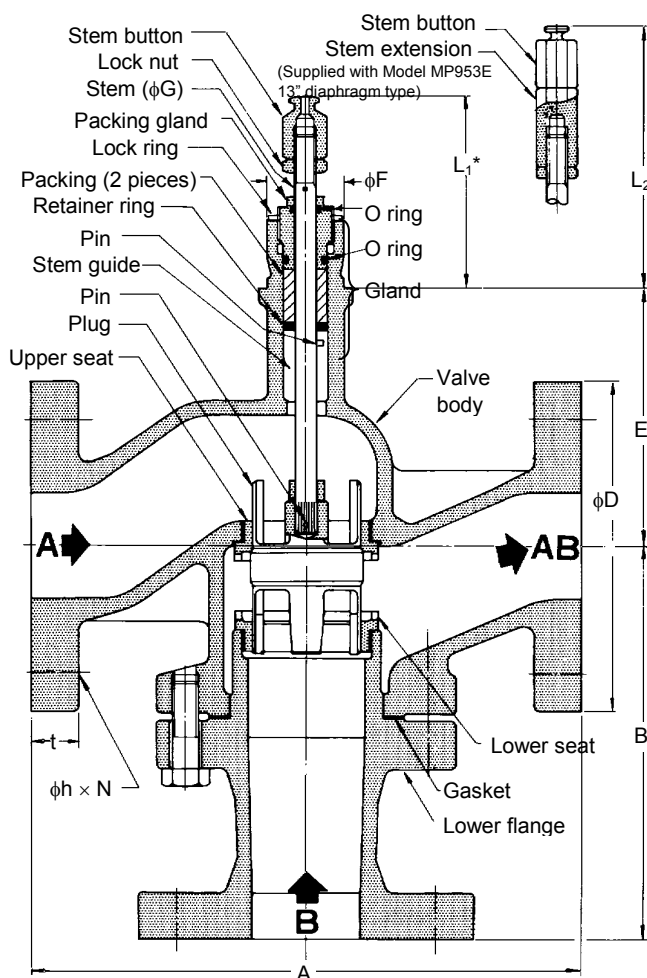

Figure 4. Close-off ratings: Model V5065A combined with Model MP953E (13" diaphragm type)

Dimensions and Parts Identification



L₂* is the dimension for Model V5065A DN100 to DN150 valves combined with Model MP953 13" diaphragm type.

Table 2. Dimensions (mm)

Size (DN)	25	40	50	65	80	100	125	150
L ₁ *	107	107	107	107	107	170.5	170.5	170.5
L ₂ *						227.5	227.5	227.5
A	184	222	254	276	298	352	403	451
B	115	160	185	225	240	250	270	310
E	88	103	117	140	152	168	190	210
D (φ)	125	140	155	175	185	210	250	280
t	18	20	20	22	22	24	24	26
h (φ)	19	19	19	19	19	19	23	23
N	4	4	4	4	8	8	8	8
F (φ)	34.8	34.8	34.8	34.8	34.8	47.6	47.6	47.6
G (φ)	8	8	10	10	10	10	13	13

Note:
L₁ and L₂ figures are the dimensions when the plug is in the highest position (the upper seat [ports A → AB] is fully closed).

Figure 5. Parts identification

Precautions for Installation

- Do not install the valve to the pipe where water hammer occurs, or slag and other solid objects may accumulate.
- Install the valve in a position allowing easy access for maintenance and inspection. Be sure to secure enough clearance around the valve for maintenance and inspection (e.g., attaching/detaching the actuator, replacing a packing, etc.). See the figures A to E of Fig. 6 for the minimum clearance to detach the actuator. When installing the valve in a ceiling space, provide an access hole for inspection within 50 cm radius from the valve. Additionally, place a drain pan under the valve.
- Install a bypass pipe, and respectively install gate valves on the inflow, outflow and bypass sides. Also, install a strainer on the inflow side.
- To prevent the valve stem from being damaged and distorted, the stem is covered with a protective tube before shipment. Remove the tube right before mounting the actuator.
- Install the valve so that the fluid flowing direction agrees with the arrow indicated on the valve body.
- The valve should be installed with its actuator vertically positioned above the valve.
- When the valve is combined with Model MY3000, MY9402, or MY9403, install the valve with the motor shaft being horizontal.

Mounting of Actuator

Mounting of Model MY3000 control motor:

Refer to Specifications/Instructions manual of Model Q455 valve linkage.

Mounting of Model MY9402 / MY9403 high-torque actuator:

Remove the stem button screwed on the top of the stem. Mount the actuator with the Model QMY9400A yoke assembly (for DN40 to DN80 valves) or Model QMY9400B yoke assembly (for DN100 to DN150 valves).

Refer to Specifications/Instructions manual of Model MY940X.

Mounting of Model MP912 / MP953C / MP953E (5" diaphragm type) pneumatic valve actuator:

For the actuator Model MP912, MP953C, or MP953E (5" diaphragm type), the actuator can be mounted directly onto the valve. Note that the stem button is screwed and locked at the exact position on the valve stem before shipment. If the position is shifted, reset it to the position specified with 'L₁' in Table 2 by adjusting the lock nut.

Refer to Specifications/Instructions manuals of respective actuators.

Mounting of Model MP953E (13" diaphragm type) pneumatic valve actuator:

For the actuator Model MP953E (13" diaphragm type), remove the stem button from the valve, and insert it into the stem extension (supplied with the actuator). Insert the stem extension with the stem button into the valve stem so that the stem button is positioned at 'L₂' in Table 2. Then, mount the actuator onto the valve.

Refer to Specifications/Instructions manual of Model MP953E.

Mounting Dimensions

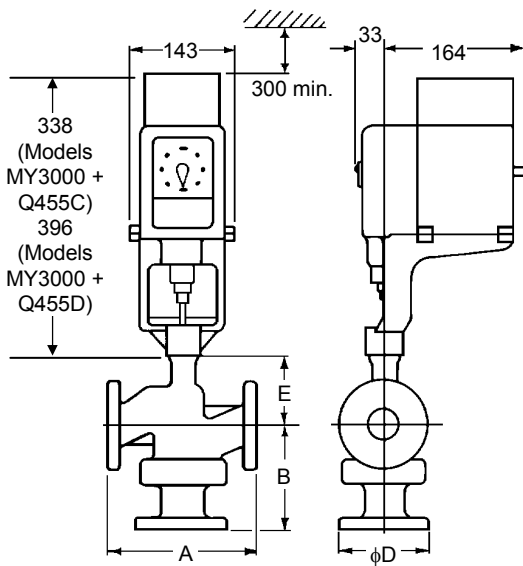

A. Model V5065A combined with Models MY3000 and Q455C/Q455D

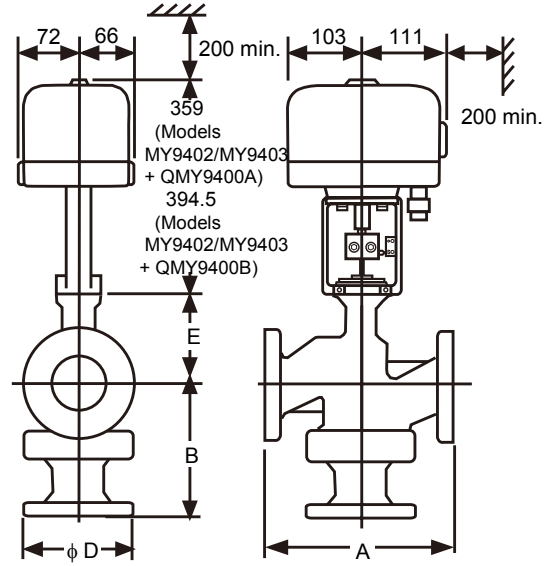

B. Model V5065A combined with Models MY9402/MY9403 and QMY9400A/QMY9400B

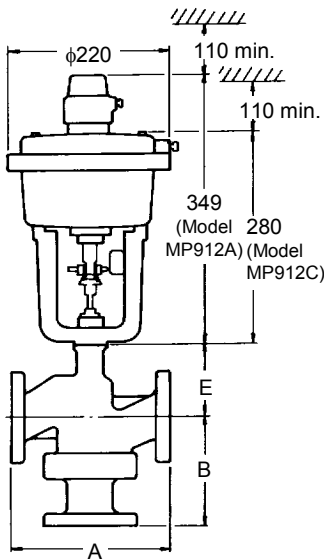

C. Model V5065A combined with Model MP912A/MP912C

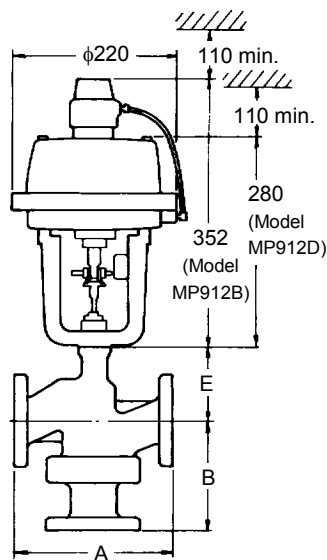

D. Model V5065A combined with Model MP912B/MP912D

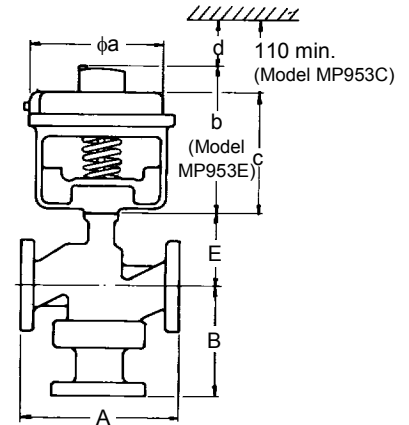

Actuators		a	b	c	d
Model MP953E	5" type	130	235	117	300 min.
	13" type	343	460	254	300 min.
Model MP953C	5" type	130		117	

E. Model V5065A combined with Model MP953C/MP953E

Valve size (DN)	25	40	50	65	80	100	125	150
A	184	222	254	276	298	352	403	451
B	115	160	185	225	240	250	270	310
E	88	103	117	140	152	168	190	210
D (φ)	125	140	155	175	185	210	250	280

Figure 6. Mounting dimensions: Model V5065A with actuator mounted

Inspection and Maintenance

 WARNING



- Do not touch the installed valve. When being used to control hot water, the valve reaches high temperature and may result in burn injury.

Visually inspect fluid leakage from the inside of the valve body every three months. To prevent the fluid leakage from the gland, fasten the packing with the packing gland nut. Replace the packing if it does not completely seal the gland.

For the actuator inspection and maintenance, refer to the related manuals.

azbil

Specifications are subject to change without notice.

Yamatake Corporation
Building Systems Company

<http://www.yamatake.com>