

## Valve Linkages

### Models Q455C, Q455D, Q455F

#### General

Model Q455C / Q455D / Q455F valve linkage series connects the Model MY3000 Control Motor and a control valve. The crank mechanism of the valve linkage converts the rotary motion of the Control Motor into the reciprocating motion to open and close the valve.

Model Q455C is used for a small- or middle-size valve; Model Q455D is used for a large-size valve; and Model Q455F, combined with a low-torque spring-return actuator, is used for a small-size valve.

#### Features

- Easy-to-read indicator of the valve position.
- Strain relief mechanism:  
Prevents excessive forces imposed on the Control Motor when the valve is fully closed.
- Easy adjustment and installation

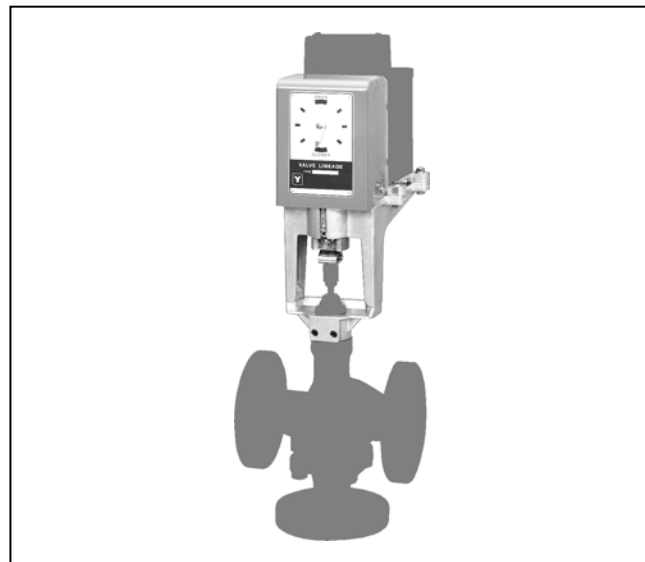

#### Model Numbers

Model number	Max. thrust of the valve stem	Adjustable range of the valve lift
Q455C	715 N	9.5 mm to 19 mm
Q455D	715 N	9.5 mm to 38 mm
Q455F	352 N	9.5 mm to 19 mm

#### Specifications

Item	Specification	
Coating	Cover: Gray enamel Frame: Aluminum die casting (primary coat)	
Accessories	Parts and tool to mount the Control Motor Bolts, nuts, washers (4 for each) and a 4-mm Allen wrench	
Replacement parts (Separate order is required.)	Cover assembly	Part No. 170110A
	Bracket assembly (for Model Q455C/Q455F)	Part No. 81404199-001
	Bracket assembly (for Model Q455D)	Part No. 81404199-002
	Guide tube assembly for Model Q455C/Q455D	Part No. 81404200-001
	Guide tube assembly for Model Q455F	Part No. 81404200-002
	Crank arm	Part No. 186511
	Stem clamp	Part No. 81446017-001
Requirement for ordering	Attachment parts set	Part No. N-3033
	Stopper	Part No. N-5014
Requirement for ordering	Model number / part number	

**Combination of Valve, Control Motor, and Linkage**

Rotation angle	Valve Actuator	Single-seated two-way valve	Double-seated two-way valve		Three-way mixing valve	
		Model V5063A	Model V5064A		Model V5065A	
		DN15 to 80	DN40 to 80	DN100 to 150	DN25 to 80	DN100 to 150
160°	Models M9185A1075-2, M6285A1047-2 (Spring-return model) Production and sales stopped. For maintenance service only.	Model Q455F		Not available*	Model Q455F	Not available
160°	Model MY3000F0400	Model Q455C		Model Q455D	Model Q455C	Model Q455D
160°	Models MY3000D0200, MY3000E0200, MY3000F0200, MY3000G0200, MY3000V0200, MY3000G9200					

\* Note:

Model Q455D valve linkage cannot be combined with a low-torque (less than 12.5 N·m) actuator including Models M9185A1075-2, M6285A1047-2, and MY3000F0400.







**Safety Instructions**

Please read instructions carefully and use the product as specified in this manual. Be sure to keep this manual near by for ready reference.

**Usage Restrictions**

This product is targeted for general air conditioning. Do not use this product in a situation where human life may be affected. If this product is used in a clean room or a place where reliability or control accuracy is particularly required, please contact Yamatake's sales representative. Yamatake Corporation will not bear any responsibility for the results produced by the operators.

 CAUTION

-  • Installation must be performed by qualified personnel in accordance with all applicable safety standards.
-  • Installation must be carried out according to the operating conditions (temperature, humidity, power, vibration, shock, installation position, atmospheric conditions, etc.) specified in this manual to prevent product damages.
-  • This product must be operated within its operating ranges specified in this manual. Failure to comply will cause equipment damages.
-  • Avoid any application that keeps the product operating cycle excessively frequent so as not to shorten the product service life.
-  • Do not put heavy load on the product.
-  • Do not disassemble the product except when assembling the valve and actuator with the product, or when adjusting or replacing a part of the product.
-  • Do not incinerate this product for waste disposal. Do not recycle all or part of this product, either.

**IMPORTANT:**

Refer to the related literature of the valve and the actuator combined with the Model Q455C/Q455D/Q455F valve linkage

**Dimensions**

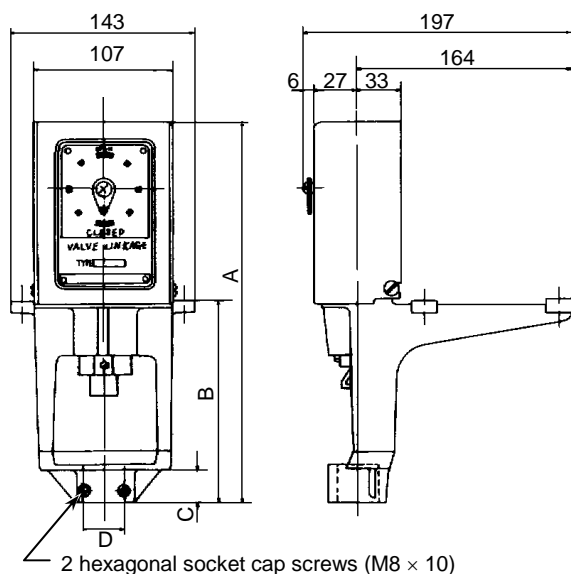

Model number	A	B	C	D
Q455C	289	153	25	φ34.9
Q455D	347	211	83	φ47.7
Q455F	289	153	25	φ34.9

Figure 1. Dimensions (mm)

**Precautions for Installation (Assembling valve and Control Motor with valve linkage)**

- Make sure that the combination of valve, Control Motor, and valve linkage is correct.
- Install the valve and Control Motor with the valve linkage in a location where maximum pressure drop/close-off rating is lower than the rated as shown in the table **Close-Off Rating / Maximum Pressure Drop**.
- To protect the Control Motor and valve linkage from condense water (splashing over them), position the valve linkage vertically above the valve. Always keep the motor shaft in horizontal position to install.

**Close-Off Rating / Maximum Pressure Drop**

For the single-seated valves and three-way valves, close-off rating is shown in the table below. For the double-seated valves, maximum pressure drop is shown in the table below.

Valve			Close-off rating / Max. pressure drop (kPa)		
Model number	Size (DN)	Cv	Valve linkage model		
			Q455C	Q455D	Q455F
V5063A single-seated	15 × 6	0.6	980	/	980
	15 × 8	1.0	980	/	980
	15 × 10	2.5	980	/	980
	15 × 15	4.0	980	/	980
	25 × 20	6.3	980	/	980
	25 × 25	11	980	/	539
	40 × 32	17	470	/	225
	40 × 40	25	470	/	225
	50 × 50	44	313	/	137
V5064A double-seated	80 × 80	68	186	/	88
	80 × 80	99	127	/	58
	40 × 32	20	980	/	862
	40 × 40	28	980	/	862
	50 × 50	50	980	/	637
	65 × 65	78	882	/	441
V5065A three-way mixing	80 × 80	112	686	/	343
	100 × 100	200	/	490	/
	125 × 125	260	/	294	/
	150 × 150	380	/	245	/
	25 × 20	6.3	980	/	539
	25 × 25	11	980	/	539
V5065A three-way mixing	40 × 32	18	470	/	225
	40 × 40	28	470	/	225
	50 × 50	50	313	/	137
	65 × 65	72	186	/	84
	80 × 80	102	127	/	55
	100 × 100	188	/	81	/
	125 × 125	280	/	47	/
	150 × 150	360	/	33	/

**Connecting Valve Linkage to Valve and Control Motor**

- 1) Tighten the setscrews with the linkage frame attached to the valve bonnet.

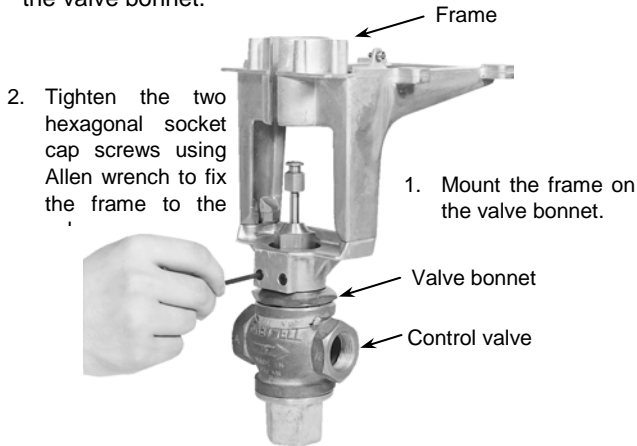

Figure 2. Mounting frame onto the valve bonnet

- 2) Place guide tube in frame cylinder.
- 3) Place clamp on stem button neck and connect guide tube to the stem.

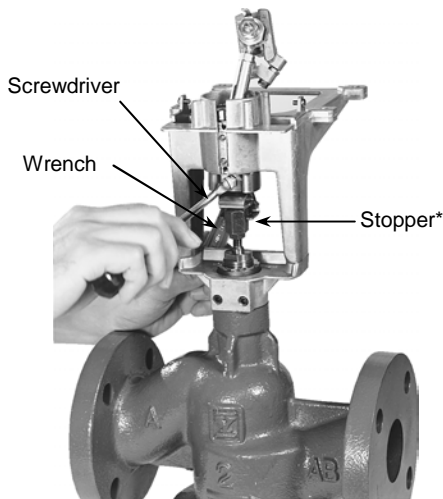

Figure 3. Connecting guide tube to valve stem

\* Note:

When connecting the valve linkage to double-seated valve, provide the stopper (Part No. N-5014, requiring separate order).

- 4) Place the Control Motor on the linkage frame and connect the Control Motor tightly with the accessory bolts, nuts and washers (4 for each).
- 5) Make sure that the Control Motor is in closed position by checking the key groove of the motor shaft.

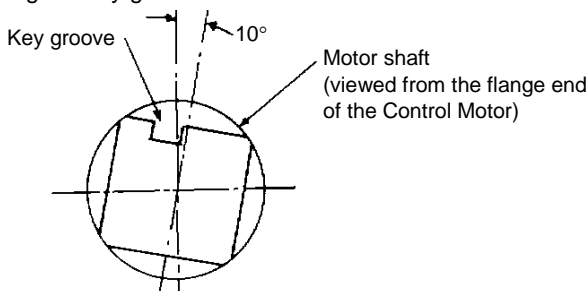

Figure 4. Motor shaft of the Control Motor in closed position

- 6) To connect the valve linkage to the Control Motor, insert crank arm in the motor shaft. Be sure to meet the raised part of the crank arm with the key groove of the motor shaft.

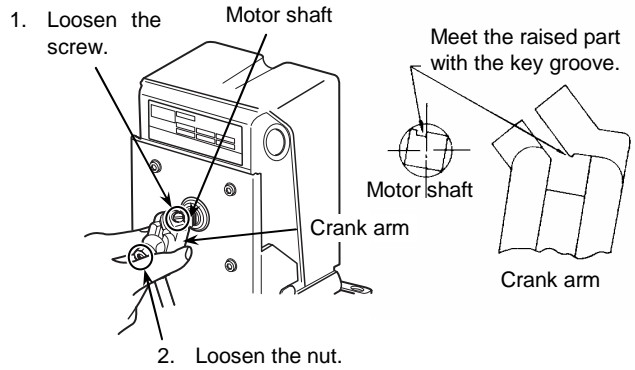

Figure 5. Connecting valve linkage to Control Motor

- 7) To set the valve lift, turn the adjustment shaft by finger to set the red indicator on the scale to the proper position.

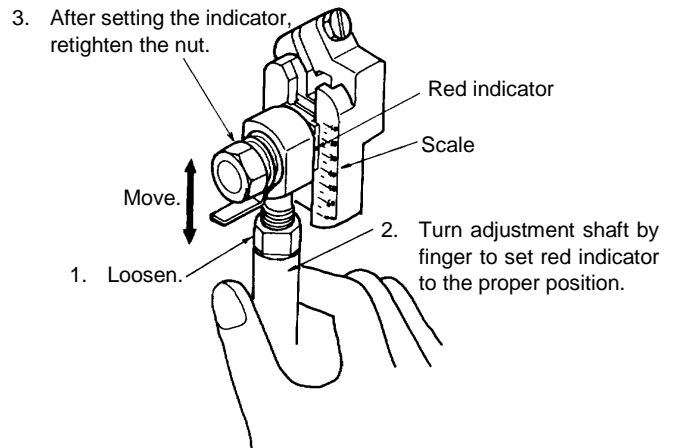

Figure 6. Setting valve lift

For two-way valve: Lift distance + approx. 3.5 mm (e.g., set at 22.5 mm on the scale for 19 mm lift.)  
 For three-way valve: Lift distance + approx. 6 mm (e.g., set at 25 mm on the scale for 19 mm lift.)

- 8) To adjust strain relief, turn the adjustment shaft using a wrench as shown in Fig. 7, so that the positions of the washers shift a half or one scale. (See Figs. 8 and 9.) Carefully adjust the shaft. Excessively moving of washers may damage the strain relief mechanism and other components.

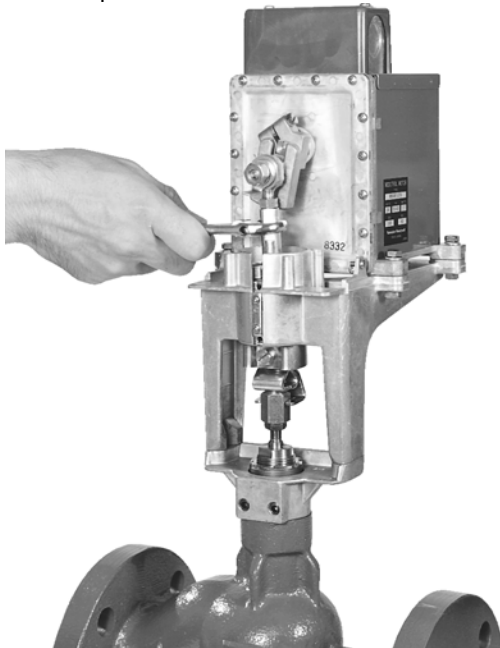

Figure 7. Adjusting the strain relief

Adjusting the strain relief for two-way valve

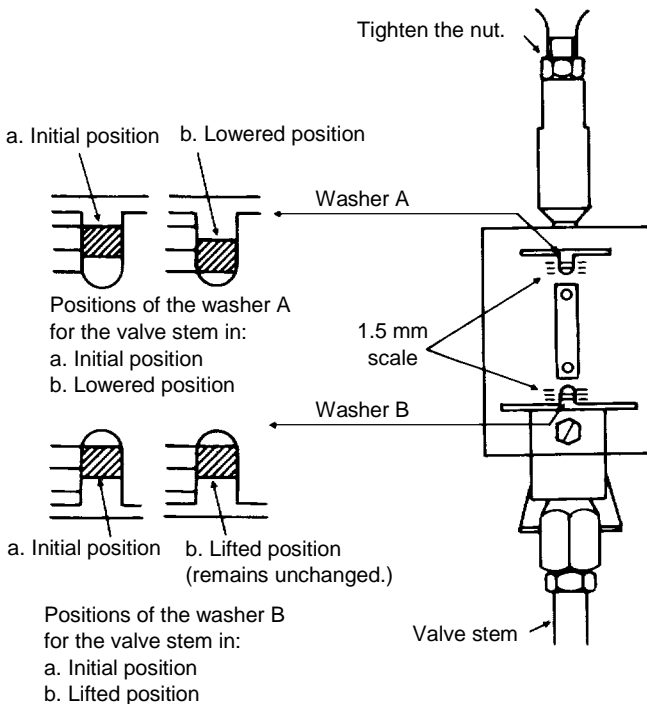

Figure 8. Adjusting the strain relief for two-way valve

Position of the washer B remains unchanged when the valve stem is lifted. If the position shifts above the initial position, go back to 7) of the procedure and readjust the setting by slightly reducing the stroke.

Adjusting the strain relief for three-way valve

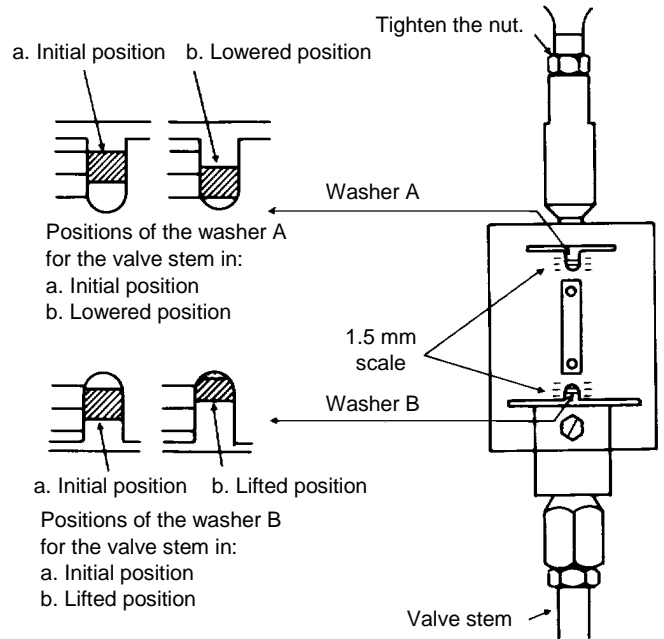

Figure 9. Adjusting the strain relief for three-way valve

Make sure that the washers A and B shift for half or one scale.

If the washers A and B shift less than a half scale, go back to 7) of the procedure and readjust the setting by slightly increasing the stroke.

If the washers A and B shift more than one scale, go back to 7) and readjust the setting by slightly reducing the stroke.

- 9) Tighten the locknut.
- 10) Insert the pin in the guide slot on the rear side of the front cover.

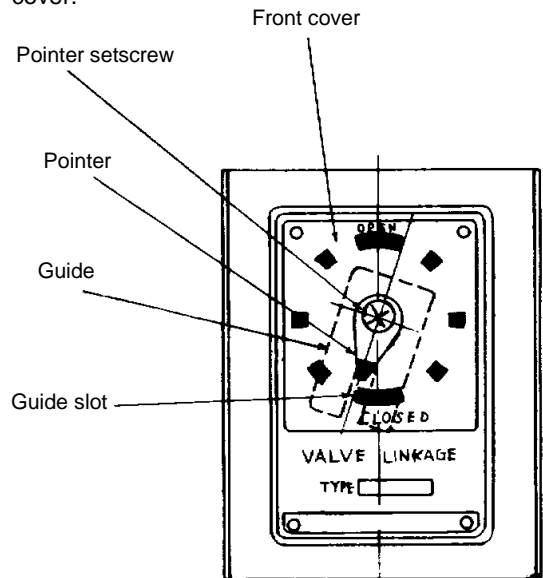

Figure 10. Mounting front cover

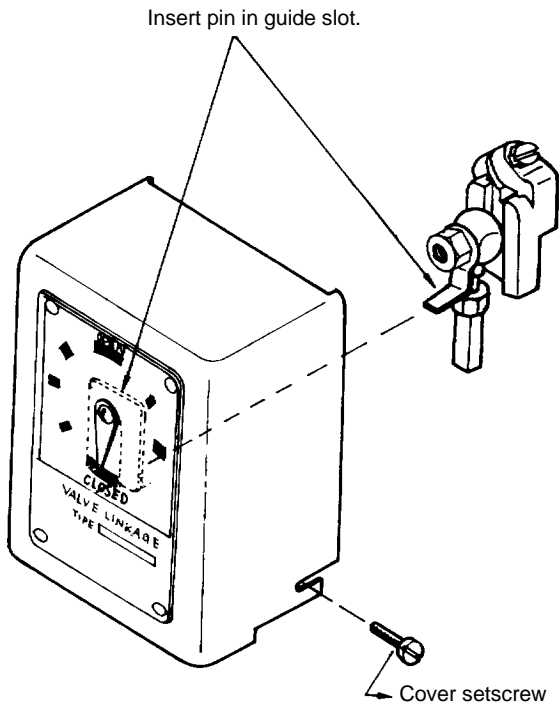

Figure 11. Inserting pin in guide slot

To switch the pointer rotation (indicating the valve position) to the reverse rotation, remove the pointer setscrew and the pointer, and set the pointer to the opposite side, then tighten the pointer setscrew again.

### Maintenance

Inspect the valve linkage connecting the valve and Control Motor every half year. Check that there is no degraded parts or loosened screws.

Replace parts or the whole product if necessary.



**azbil**

*Specifications are subject to change without notice.*

**Yamatake Corporation**  
**Building Systems Company**

**<http://www.yamatake.com>**