

# CV3000 Series Multismotor Multi-Spring Type, Lever-Actuated Diaphragm Motors Model HL

## OVERVIEW

The Multismotor Model HL is a multi-spring type, lever-actuated diaphragm motor featuring small size and lightweight. This motor, employing a lever to extend motion of the actuator stem, is used to operate control rods of dampers, cock valves, or other items.

## SPECIFICATIONS

### Types

Action	Model		
Direct	HL2D	HL3D	HL4D
Reverse	HL2R	HL3R	HL4R

#### 1) Direct action

As the air pressure fed to the top chamber of the diaphragm case increases, the actuator stem moves downward.

#### 2) Reverse action

As the air pressure fed to the bottom chamber of the diaphragm case increases, the actuator stem moves upward.

### Material

- Diaphragm case  
SS400
- Diaphragm  
Cloth embedded ethylene propylene rubber
- Actuator stem  
SUS403 stainless steel
- Yoke  
FC200
- Lever  
S45C
- Fork  
S20C
- Pin  
SUS304
- Base  
SS400

### Spring range

20 to 98 kPa {0.2 to 1.0 kgf/cm<sup>2</sup>}  
80 to 240 kPa {0.8 to 2.4 kgf/cm<sup>2</sup>}

### Supply pressure

140 to 390 kPa {1.4 to 4.0 kgf/cm<sup>2</sup>}

### Air connection

Rc 1/4 or 1/4NPT internal thread

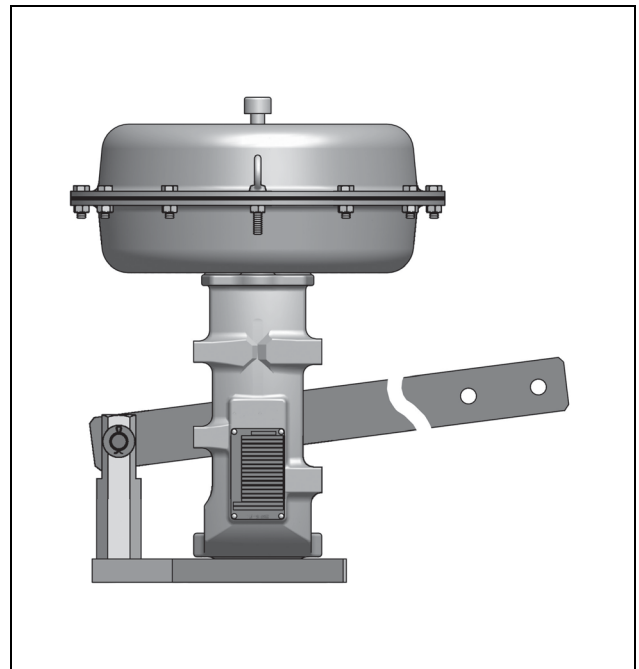

### Ambient temperature

-30°C to +70°C

### Optional accessories

Positioner\*, pressure regulator with filter, hand wheel\*, limit switch, solenoid valve, motion transmitter, booster relay, lock-up valve, and others.

Note) 1) For the optional items, refer to the specification sheets and installation drawing of respective accessories.

2) Accessories with the asterisk mark (\*) are selected from the following types depending on the actuators to be combined.

Actuator	Positioner		Hand wheel	
	P/P	I/P	Top	Side
HL2 to 4	HTP	AVP/HEP	THM	-

### Performance

#### Output

Refer to Table 2.

#### Accuracy

Refer to Table 1.

### Dimensions and weight

Refer to Figure 1, 2 and 3 and Table 6.

### Finish

Blue (Munsell 10B5/10), silver or other specified colors.

Table 1 Hysteresis error and linearity

[Within %F.S.]

Item		Spring range	20 to 98 kPa {0.2 t o 1.0 kgf/cm <sup>2</sup> }	80 to 240 kPa {0.8 to 2.4 kgf/cm <sup>2</sup> }
Hysteresis error	Without positioner		3	5
	With positioner		1	1
Linearity	Without positioner		±5	±10
	With positioner	HTP	±1	±1
		AVP/HEP	±1	±1

Note) When no positioner is provided, performance varies depending on the type of packing used.

## Output

Table 2 Direct action (Downward output N)

Model number	Supply pressure kPa	Spring range kPa	Positioner	Lever position						
				L <sub>1</sub>	L <sub>2</sub>	L <sub>3</sub>	L <sub>4</sub>	L <sub>5</sub>	L <sub>6</sub>	L <sub>7</sub>
HL2D	140	20~98	△	1280~ 420	1100~ 360	960~ 310	850~ 280	770~ 250	700~ 220	640~ 200
	160	20~98	○	1500~ 640	1280~ 550	1130~ 480	1000~ 420	900~ 380	810~ 340	740~ 310
	390	80~240	○	3440~1720	2950~1470	2580~1280	2290~1150	2060~1030	1870~ 930	1720~ 850
HL3D	140	20~98	△	2170~ 720	1800~ 600	1540~ 510	1350~ 450	1200~ 390	1080~ 350	—
	160	20~98	○	2520~1080	2100~ 900	1800~ 760	1580~ 680	1400~ 600	1260~ 540	—
	390	80~240	○	5780~2880	4820~2400	4120~2060	3614~1800	3210~1600	2880~1440	—
HL4D	140	20~98	△	3800~1260	3170~1050	2710~ 900	2370~ 780	2110~ 700	1890~ 630	—
	160	20~98	○	4430~1890	3690~1580	3170~1350	2760~1190	2460~1050	2220~ 940	—
	390	80~240	○	10130~5060	8440~4220	7240~3620	6340~3170	5630~2810	5060~2530	—

Table 3 Direct action (Upward output N)

Model number	Supply pressure kPa	Spring range kPa	Positioner	Lever position						
				L <sub>1</sub>	L <sub>2</sub>	L <sub>3</sub>	L <sub>4</sub>	L <sub>5</sub>	L <sub>6</sub>	L <sub>7</sub>
HL2D	140	20~98	△	200~1070	180~ 920	160~ 800	140~ 720	130~ 670	110~ 580	98~ 530
	160	20~98	○	200~1070	180~ 920	160~ 800	140~ 720	130~ 670	110~ 580	98~ 530
	390	80~240	○	850~2580	740~2210	640~1930	570~1720	510~1550	460~1400	420~1280
HL3D	140	20~98	△	350~1800	290~1500	250~1280	220~1130	200~1000	180~ 900	—
	160	20~98	○	350~1800	290~1500	250~1280	220~1130	200~1000	180~ 900	—
	390	80~240	○	1440~4330	1200~3610	1030~3090	900~2710	790~2400	720~2170	—
HL4D	140	20~98	△	630~3170	520~2640	450~2260	390~1970	340~1760	310~1580	—
	160	20~98	○	630~3170	520~2640	450~2260	390~1970	340~1760	310~1580	—
	390	80~240	○	2530~7600	2110~6340	1800~5420	1580~4750	1400~4220	1260~3800	—

Table 4 Reverse action (Downward output N)

Model number	Supply pressure kPa	Spring range kPa	Positioner	Lever position						
				L <sub>1</sub>	L <sub>2</sub>	L <sub>3</sub>	L <sub>4</sub>	L <sub>5</sub>	L <sub>6</sub>	L <sub>7</sub>
HL2R	140	20~98	△	1070~ 200	920~ 180	800~ 160	720~ 140	670~ 130	580~ 110	530~ 98.0
	390	80~240	○	2580~ 850	2210~ 740	1930~ 640	1720~ 570	1550~ 510	1400~ 460	1280~ 420
HL3R	140	20~98	△	1800~ 350	1500~ 290	1280~ 250	1130~ 220	1000~ 200	900~ 180	—
	270	80~240	○	4330~1440	3610~1200	3090~1030	2710~ 900	2400~ 790	2170~ 720	—
HL4R	140	20~98	△	3170~ 630	2640~ 520	2260~ 450	1970~ 390	1760~ 340	1580~ 310	—
	270	80~240	○	7600~2530	6340~2110	5420~1800	4750~1580	4220~1400	3800~1260	—

Table 5 Reverse action (Upward output N)

Model number	Supply pressure kPa	Spring range kPa	Positioner	Lever position						
				L <sub>1</sub>	L <sub>2</sub>	L <sub>3</sub>	L <sub>4</sub>	L <sub>5</sub>	L <sub>6</sub>	L <sub>7</sub>
HL2R	140	20~98	△	420~1280	360~1100	310~ 960	280~ 850	250~ 770	220~ 700	200~ 640
	390	80~240	○	1720~3440	1470~2950	1280~2580	1150~2290	1030~2060	930~1870	850~1720
HL3R	140	20~98	△	720~2170	600~1800	510~1540	450~1350	390~1200	350~1080	—
	390	80~240	○	2880~5780	2400~4820	2060~4120	1800~3610	1600~3210	1440~2880	—
HL4R	140	20~98	△	1260~3800	1050~3170	900~2710	780~2370	700~2110	630~1890	—
	390	80~240	○	5060~10130	4220~8440	3620~7240	3170~6340	2810~5630	2530~5060	—

Note) 1) Output denotes values from upper limits to lower limits of strokes.

2) ○ : Positioner is necessary. △ : Can be operated either with or without positioner.

**DIMENSIONS**

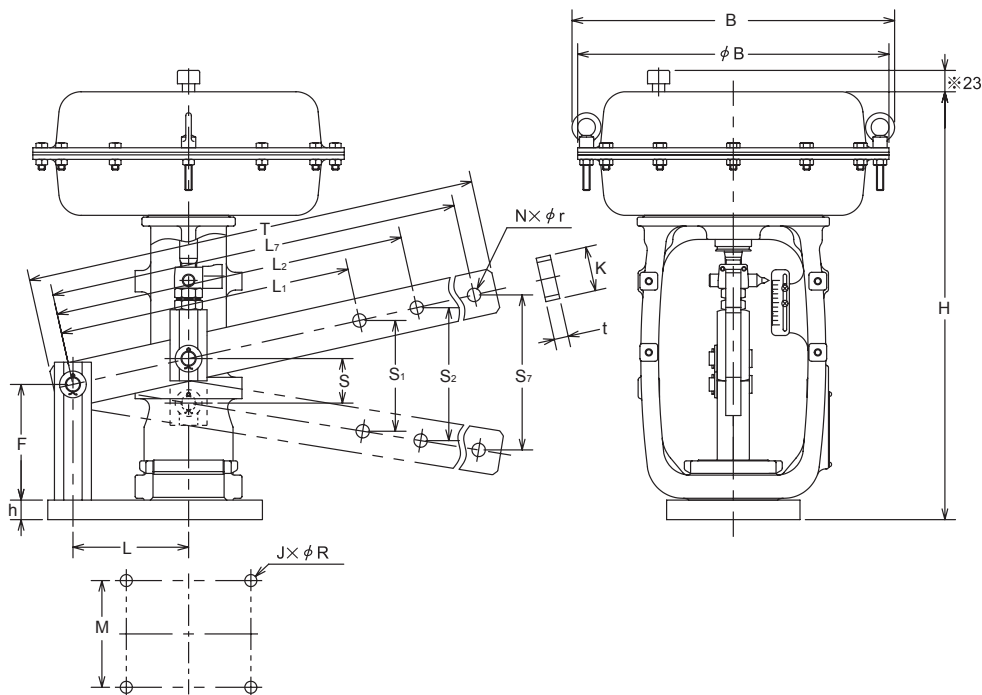

Figure 1 Dimensions of HL Multismotor

Note) In case of the reverse action actuator, the lever is moved to be position in dicated with two-dot broken lines when a pneumatic pressure signal applied is zero. The reverse action actuator provides the drop-proof cap on the upper part of the diaphragm case. (\*)

Table 6 Dimentions and weight (Dimensions of HL Multismotors)

Model number	Stroke (mm)	Dimensions (mm)											
		$\phi B$	B	H	F	h	K	t	T	$J \times \phi R$	$N \times \phi r$	E	M
HL2D, R	25	267	281	349	80	16	38	12	520	4×13.5	7×10	120	100
HL3D, R	50	350	363	481	130	22	50	16	710	4×13.5	6×15	140	120
HL4D, R	75	470	520	637	160	25	65	19	860	4×22.0	6×20	190	160

Model number	Dimensions (mm)																Nominal diaphragm area (cm <sup>2</sup> )	Maximum diaphragm chamber capacity (cm <sup>3</sup> )	Weight (kg)
	S	L	S <sub>1</sub>	L <sub>1</sub>	S <sub>2</sub>	L <sub>2</sub>	S <sub>3</sub>	L <sub>3</sub>	S <sub>4</sub>	L <sub>4</sub>	S <sub>5</sub>	L <sub>5</sub>	S <sub>6</sub>	L <sub>6</sub>	S <sub>7</sub>	L <sub>7</sub>			
HL2D, R	25	100	60	240	70	280	79	320	89	360	99	400	109	440	119	480	310	1100	22
HL3D, R	50	130	125	330	150	396	175	462	200	528	224	594	249	660	-	-	550	3400	45
HL4D, R	75	160	183	400	219	480	256	560	292	640	329	720	365	800	-	-	950	10000	95

Table 7 Dimensions of HL Multismotors with top-mounted hand wheel

Model number	Stoke (mm)	Dimensions (mm)				Maximum required operating force (N{kgf})	Weight (kg)
		$\phi B$	B	$\phi D$	H max		
HL2D, R	25	267	281	280	D : 575 R : 558	140 {14}	30
HL3D, R	50	350	363	355	746	250 {26}	60
HL4D, R	75	470	520	570	1010	400 {41}	137

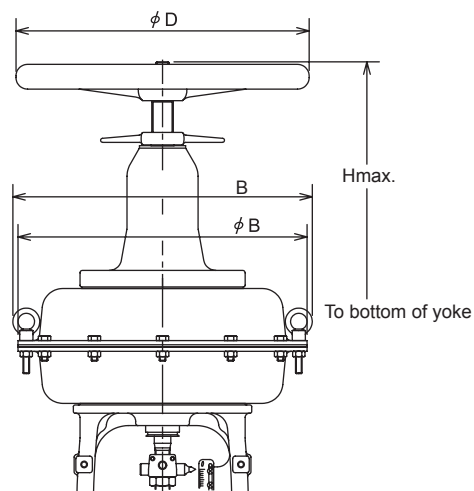

Figure 2 Dimensions of Multismotor with top-mounted hand wheel

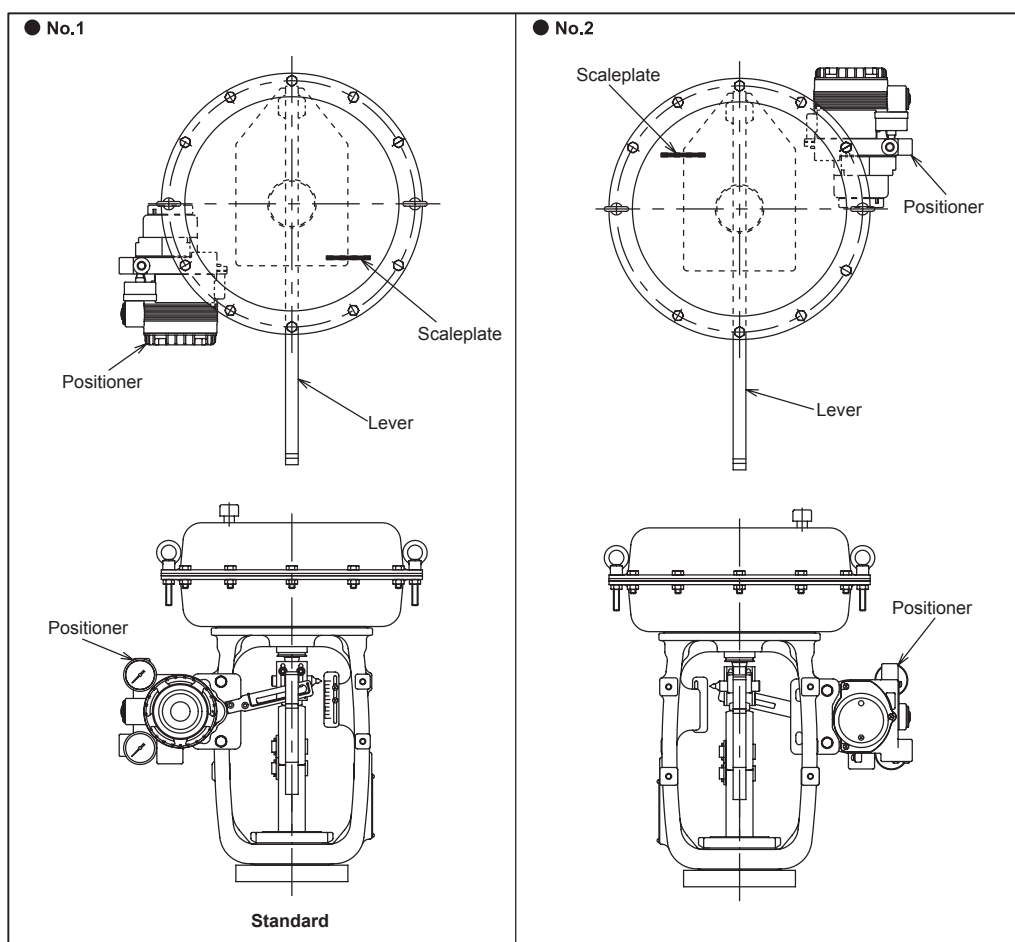

Figure 3 Actuator orientation

Note

Note

**azbil**

*Specifications are subject to change without notice.*

**Yamatake Corporation**  
**Advanced Automation Company**

1-12-2 Kawana, Fujisawa-shi  
Kanagawa-ken 251-8522 Japan

**URL:**<http://www.azbil.com>

*No part of this publication may be reproduced or duplicated without the prior written permission of Yamatake Corporation.*

Oct. 2009 (rev.4)–Y/Y