

**CV3000 Series Multismotor*
Multi-Spring Type
Diaphragm Motors
Model : HA/HL
User's Manual**

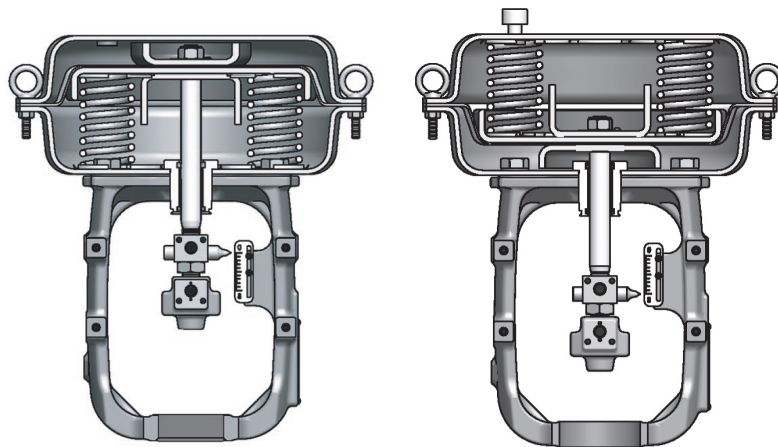

*Trademark

Yamatake Corporation

Copyright, Notices and Trademarks

Printed in Japan - ©Copyright 2007 by Yamatake Corporation Co., Ltd.

While this information is presented in good faith and believed to be accurate, Yamatake Corporation disclaims the implied warranties of merchantability and fitness for a particular purpose and makes no express warranties except as may be stated in tis written agreement with and for its customer.

In no event is Yamatake Corporation liable to anyone for any indirect, special or consequential damages, The information and specifications in this document are subject to change without notice.

TABLE OF CONTENTS

	<u>PAGE</u>
1. GENERAL	1
1.1 Scope	1
1.2 Specifications	1
1.3 Structures	2
1.4 Nameplate	3
2. INSTALLATION	4
2.1 Maximum Lifting Loads of Eyebolts	4
2.2 Items to be Checked After Installation and Before Starting Operation	4
3. INSPECTION AND MAINTENANCE	5
3.1 Routine Inspection	5
3.2 Periodical Maintenance	5
4. DISASSEMBLY AND ASSEMBLY OF ACTUATOR	6
4.1 Disassembly and Assembly of Model HA1 Actuator	8
4.2 Disassembly and Assembly of Model HA2, HA3, or HA4 Actuator	16
5. DIMENSIONS, WEIGHT AND OUTPUT OF HL	23
6. DIRECT/REVERSE ACTION TYPE CONVERSION AND SPRING RANGE CHANGE OF ACTUATOR	25
6.1 Direct/Reverse Action Change	25
6.2 Stroke and Range Spring Change	27
7. INSTRUCTIONS FOR TOP HANDWHEEL OF ACTUATOR	29
7.1 Model HA1 Actuator	29
7.2 Model HA2, HA3, or HA4 Actuator	34
8. INSTRUCTIONS FOR SIDE HANDWHEEL OF ACTUATOR	41
8.1 Installation Procedure	41
8.2 Operating Instructions	41
8.3 Disassembly and Assembly of Side Handwheel	41

1. GENERAL

1.1 Scope

This manual covers operating instructions for Model HA Multi-spring type Diaphragm Motors and Model HL Lever-type Diaphragm Motors. For Model HL Diaphragm Motors, this manual covers only the items related to the lever since other items are identical with those of Model HA Diaphragm Motors. For the positioners, refer to Operator's Manual OM2-8310-0200 (Model HTP), OM2-8313-0100 (Model HEP), OM2-8310-0410 (Model VPE).

1.2 Specifications

- Models

Action	Model			
Direct	HA1D	HA2D	HA3D	HA4D
Reverse	HA1R	HA2R	HA3R	HA4R

- 1) Direct-action Type: As the pneumatic signal fed to the top chamber of diaphragm case increases, the actuator stem moves downward.
- 2) Reverse-action Type: As the pneumatic signal fed to the bottom chamber of diaphragm case increases, the actuator stem moves upward.

- Major Materials

Diaphragm case: SS41

Diaphragm: Fiber-reinforced ethylene propylene rubber

Actuator stem: SUS304

Yoke: FC20

Lever: SS41

Fork: S20C

Pin: SUS304

Mounting base: SS41

} Model HL only

Spring range*: 20 – 100 kPa {0.2 – 1.0 kgf/cm²} or 80 – 240 kPa {0.8 to 2.4 kgf/cm²}

Air supply*: 140 – 400 kPa {1.4 to 4.0 kgf/cm²}

Air pipe connections: Rc1/4 or 1/4NPT internal thread

Ambient temperature: –30 to +70°C

*: The output differs depending on the spring range and air supply pressure.

Overall dimensions:

Weights:

Performance:

} See Section 5.

Hysteresis Error and Linearity

Item		Spring range		(within %FS)			
				20 – 100 kPa (0.2 – 1.0 kgf/cm ²)		80 – 240 kPa (0.8 – 2.4 kgf/cm ²)	
				HA1	HA2 – 4	HA1	HA2 – 4
Hysteresis error	Without positioner	5	3	—	—		
	With positioner	1	1	1	1		
Linearity	Without positioner	±5	±5	—	—		
	With positioner	VPE	±3	—	±3	—	
		HTP	—	±1	—	±1	
		HEP	±2	±1	±2	±1	

Note) When no positioner is provided, performance may differ by the type of packing used.

1.3 Structures

Model HA Multi-spring-type Diaphragm Motor has a diaphragm and springs with which to convert a pneumatic signal into a positioning signal to drive the valve stem. (See Figs. 1-1 and 1-2.)

Model HL Lever-type Diaphragm Motor has, in addition to the mechanisms identical with those of the HA diaphragm motor, a lever mechanism with which to magnify the driving stroke for the valve stem.

The Diaphragm motor can be incorporated with a manual handwheel for manual positioning of the valve stem. A handwheel is available either in a side mount type (except Model HA1) or in a top mount type.

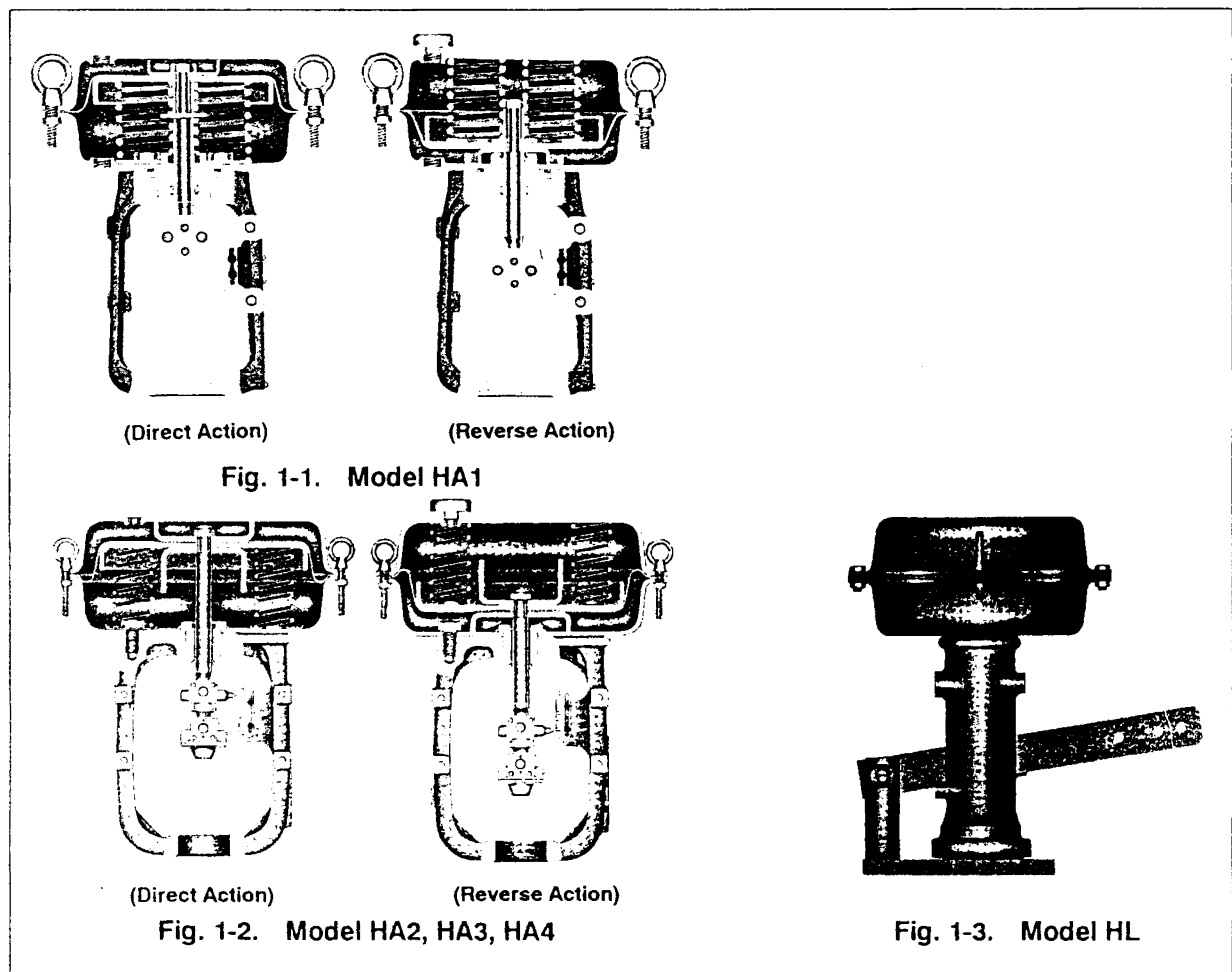

1.4 Nameplate

A nameplate as shown in Fig. 1-4 is posted on each actuator. The nameplate indicates the model number, stroke, spring range, date of manufacture and other major specifications of the actuator. Before using the actuator, be sure that the specifications indicated on the nameplate conform with the conditions of use. The nameplate indicates also the product number (PROD No.) of the actuator. Please mention this number also when consulting your Yamatake Corporation agent for replacement of parts or other modifications of the control valve.

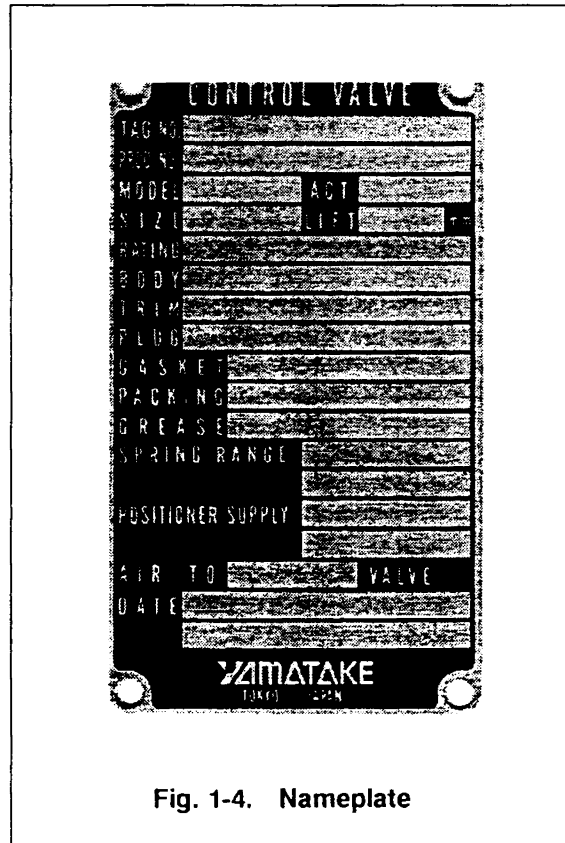

Fig. 1-4. Nameplate

2. INSTALLATION

2.1 Maximum Lifting Loads of Eyebolts

The diaphragm case has a pair of lifting eyebolts. These eyebolts primarily are for lifting the actuator alone. When using the eyebolts for other purposes (such as lifting an actuator fixed to its valve body or other components), note that the allowable maximum lifting loads of the eyebolts are as shown in the following table.

Table 2-1. Maximum Lifting Loads of Eyebolts

Actuator Model No.	Allowable Maximum Lifting Load of Eyebolts	Weight of HA Actuator Alone	Weight of HL Actuator
HA1	160 kg	8 kg	—
HA2, HL2	160 kg	16 kg	22 kg
HA3, HL3	160 kg	32 kg	45 kg
HA4, HL4	220 kg	68 kg	95 kg

A pair of eyebolts are located diagonally on the diaphragm case. They also serve as two of the diaphragm case clamping-screws. Each eyebolt has at its top a ringlet to pass the cable wire to hoist the actuator.

2.2 Item to be Checked After Installation and Before Starting Operation

- (1) Before connecting the air pipes to the actuator and positioner, blow the pipes to clean them.
- (2) Check that the bolts and nuts of the diaphragm case are not loose. Standard tightening torques are as shown in Table 4-1.
- (3) Check that there is no leak from any position.
- (4) For the HL actuator, be sure that the cotter pins of the two parallel pins which acts are pivots for the lever are correctly installed.

3. INSPECTION AND MAINTENANCE

For the actuators, render routine inspection service and periodical maintenance service as described in this section.

3.1 Routine Inspection

- (1) Check that the bolts and nuts are not loose.
- (2) Check that there are no air leakage from joints and connections of air piping.
- (3) For Model HL Actuators, check that the cotter pins of the two parallel pins which act as pivots for the lever are correctly installed.

3.2 Periodical Maintenance

The parts mentioned below must be replaced once in every 5 years or thereabout, and in addition the three types of parts mentioned at the end of the below listing must be replaced whenever the actuator is disassembled. For the replacement method, see Section 4 "DISASSEMBLY AND ASSEMBLY OF ACTUATOR."

Diaphragm	5 years	
Bushing*	5 years	
Cap	5 years	
Seal washers	5 years	whenever disassembled
Dust seal	5 years	whenever disassembled
Rod packing	5 years	whenever disassembled

*: Model HA1 Actuator has no bushing.

4. DISASSEMBLY AND ASSEMBLY OF ACTUATOR

Normally the actuator requires no adjustment. However, it should be disassembled and assembled when installing it on a valve body, when modifying its specifications, or when replacing damaged parts. The disassembly and assembly procedure of the actuator for such purposes are covered in Sections 4-1 and 4-2.

To disassemble the actuator, refer to Fig. 4-1 to Fig. 4-16.

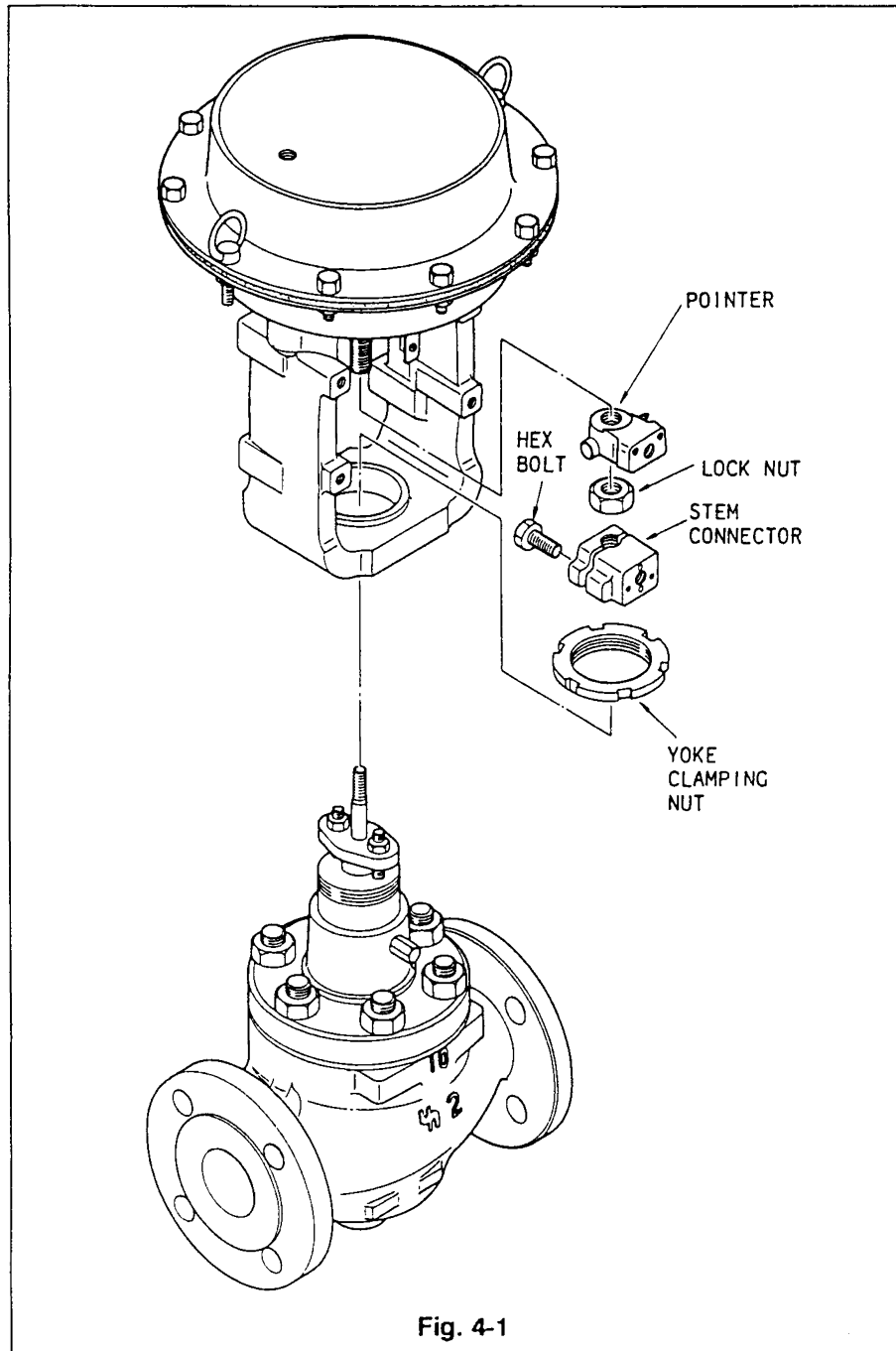

When disassembling or assembling the actuator, keep it in the vertical attitude.

For the tightening torques of bolts and nuts, see Tables 4-1, 4-2.

For the names of the parts, see Figs. 4-7, 8 and 4-16.

Notes for Disassembly

1. The nuts for the eyebolts are made of stainless steel. Discriminate these nuts from other nuts when assembling the diaphragm case.
2. It is recommendable to make locating marks on the top and bottom diaphragm cases before disassembly. This will help you to find easily the air piping connector location.
3. Store the removed parts in a clean place.

Caution: Never loosen or remove carelessly the bolts and nuts of the actuator. The actuator employs powerful compressed springs and if you remove the bolts and nuts carelessly, the springs may leap out causing hazards. When removing the bolts and nuts, be sure to observe the instructions given for disassembly and assembly procedures of the actuator and top handwheel.

4.1 Disassembly and Assembly of Model HA1 Actuator

Disassembly Procedure

(a) Direct Action Type (See Fig. 4-2.)

- (1) Disconnect the air piping and detach the accessories from the actuator.
- (2) Remove the stem connector.
- (3) Remove the clamping-bolts (except the pair of eyebolts) of the diaphragm case.
- (4) Loosen evenly and alternately the pair of eyebolts. (The initial setting of the springs is done by these eyebolts.)
- (5) Remove the diaphragm case. Pull out upward the actuator rod together with the diaphragm.
- (6) Take out the springs.

(b) Reverse Action Type (See Fig. 4-3.)

- (1) Disconnect the air piping and detach other external items from the actuator.
- (2) Remove the stem connector.
- (3) Remove the clamping-bolts (except the pair of eyebolts) of the diaphragm case.
- (4) Loosen evenly and alternately the pair of eyebolts. (The initial setting of the springs is done by the eyebolts.)
- (5) Remove the diaphragm case. Take out the spring.
- (6) Pull out upward the actuator rod together with the diaphragm.

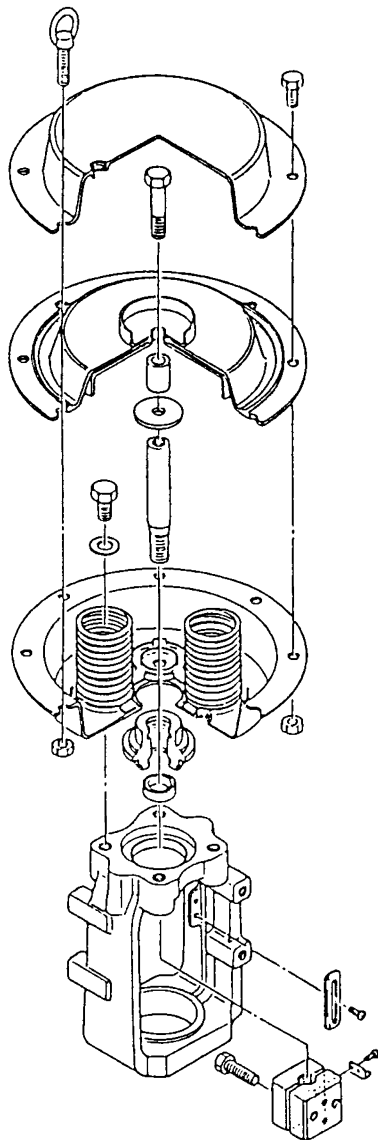

Fig. 4-2. Direct Action Type
(HA1D)

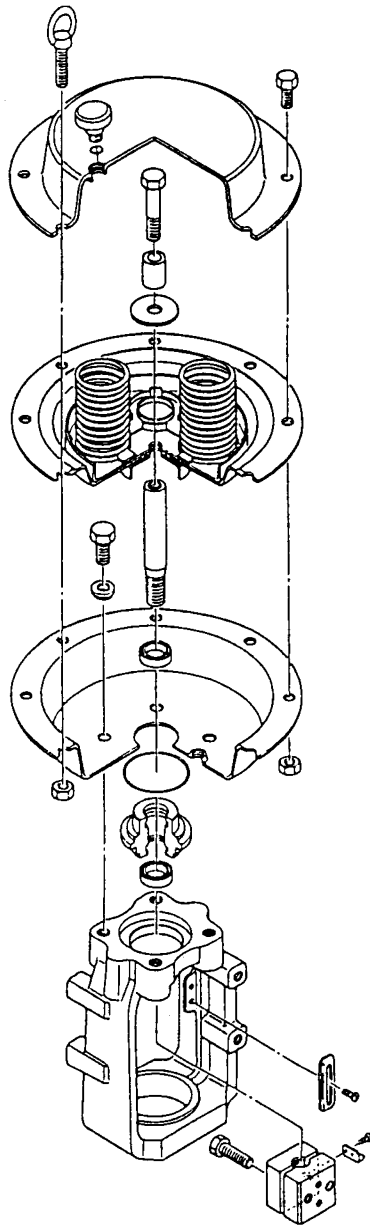

Fig. 4-3. Reverse Action Type
(HA1R)

Assembly Procedure

Before assembly, check the parts for scrapes, damage, deformation, peeling off of paint, and other abnormality. To assemble the actuator, proceed as follows:

(a) Direct Action Type

- (1) Fix the bearing (with dust seal) to the yoke. Fix the diaphragm case (bottom) with the four bolts (M10).
- (2) Fix the spring plate (see Fig. 4-4). Install the springs on the spring plate.
- (3) Insert the actuator rod (to which the diaphragm is connected) into the bearing, exercising care not to damage the bearing inside surface or dust seal with the threaded section of the rod. (For example, cover the threaded section with adhesive tape to prevent damaging the bearing.)
- (4) Place the top diaphragm case and fix it with the pair of eyebolts.

Notes:

- Set the air piping connection port in the location shown in Fig. 4-4.
- Tighten the pair of eyebolts uniformly by tightening them alternately. The initial setting of the springs is complete by tightening of these eyebolts.

- (5) Clamp the diaphragm case with other clamping-bolts than the pair of eyebolts.
- (6) Install the stem connector. (Connect the air pipe to the air piping connection port of the top diaphragm case.)
- (7) After the assembly is complete as above, check the following.
 1. Applying an air pressure of 490 kPa {5 kgf/cm²} via the air piping connection port of the top diaphragm case, check the diaphragm periphery for air leak by using soapsuds.
 2. Check that the actuator smoothly operates for its full stroke.

Note: Check this operation by operating the actuator as an independent unit.

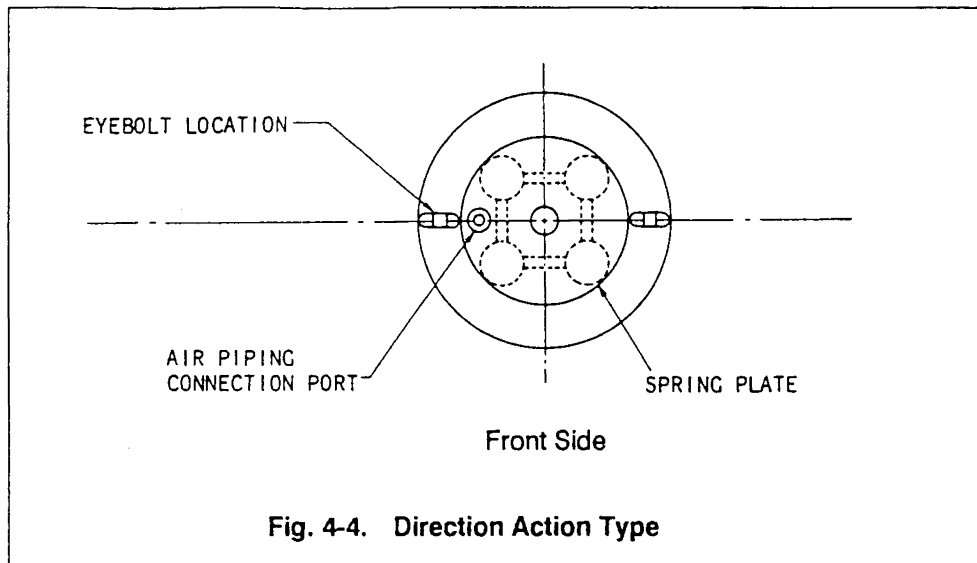

(b) Reverse Action Type

- (1) Fix the bearing (with dust seal and rod packing) and the O-ring to the yoke, and fix the bottom diaphragm case with the four bolts (M10).
- (2) Insert the actuator rod (to which the diaphragm is connected) into the bearing, exercising care not to damage the bearing inside surface or dust seal with the threaded section of the rod. (For example, cover the threaded section with adhesive tape to prevent damaging the bearing.)
- (3) Fix the spring plate and install the springs on the spring plate. (See Fig. 4-5.)
- (4) Place the top diaphragm case and fix it with the pair of eyebolts.

- Notes:
- Set the air vent hole in the location shown in Fig. 4-5.
 - Uniformly and alternately tighten the eyebolts. The initial setting of the springs is complete by tightening of these eyebolts.

- (5) Clamp the diaphragm case with other clamping-bolts than the pair of eyebolts.
- (6) Install the stem connector.
- (7) Install the rain cap on the air vent port.
- (8) Connect the air pipe to the air piping connection port of the bottom diaphragm case.
- (9) After the assembly is complete as above, check the following.
 1. Applying an air pressure of 490 kPa {5 kgf/cm²} via the air piping connection port of the bottom diaphragm case, check the diaphragm periphery for air leak by using soapsuds.
 2. Check that the actuator smoothly operates for its full stroke.

Note: Check this operation by operating the actuator as an independent unit.

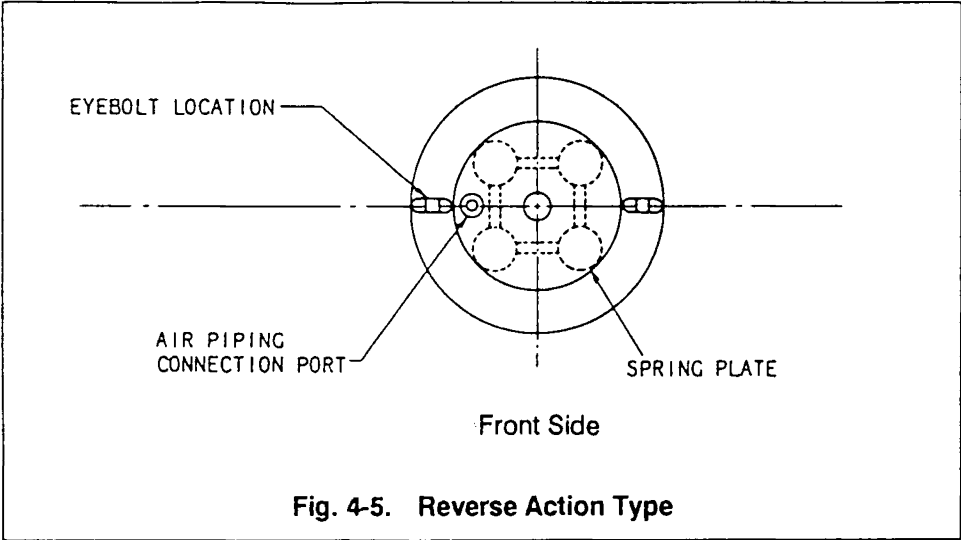

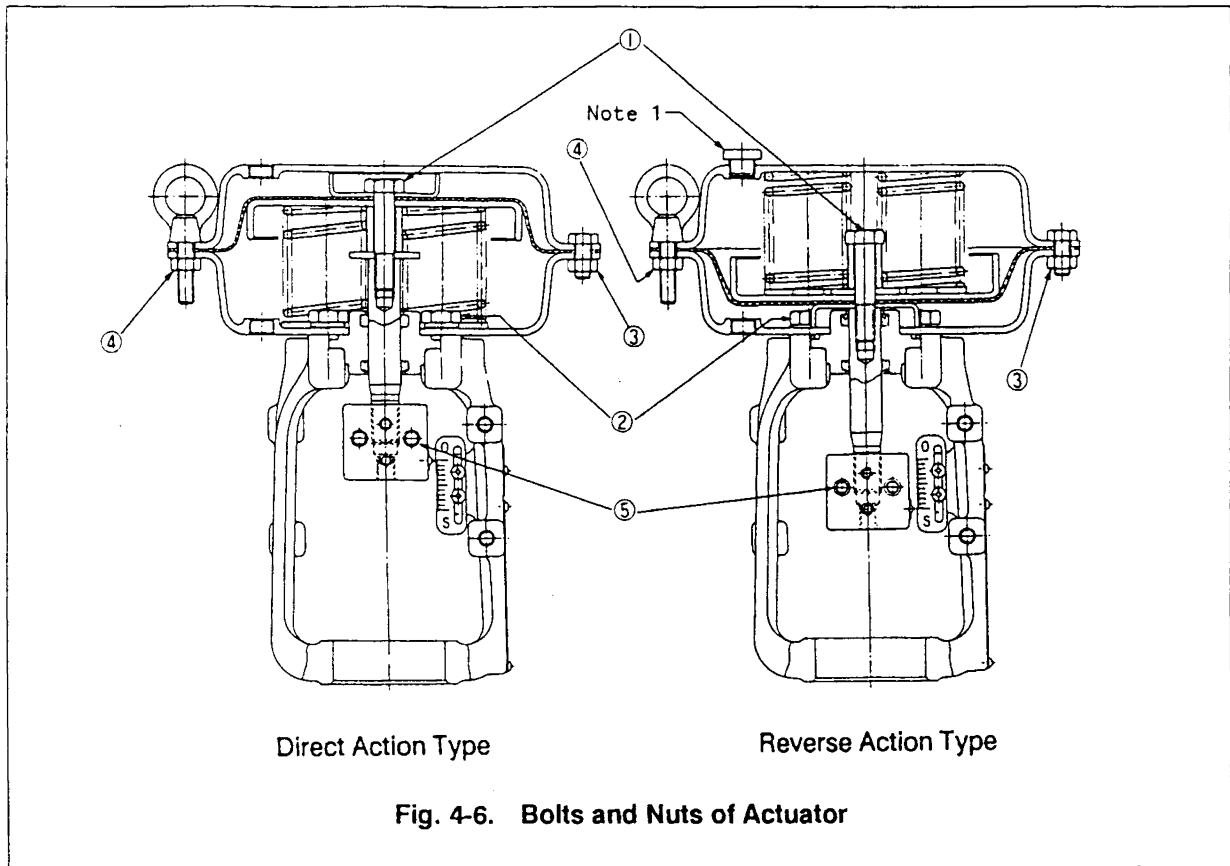
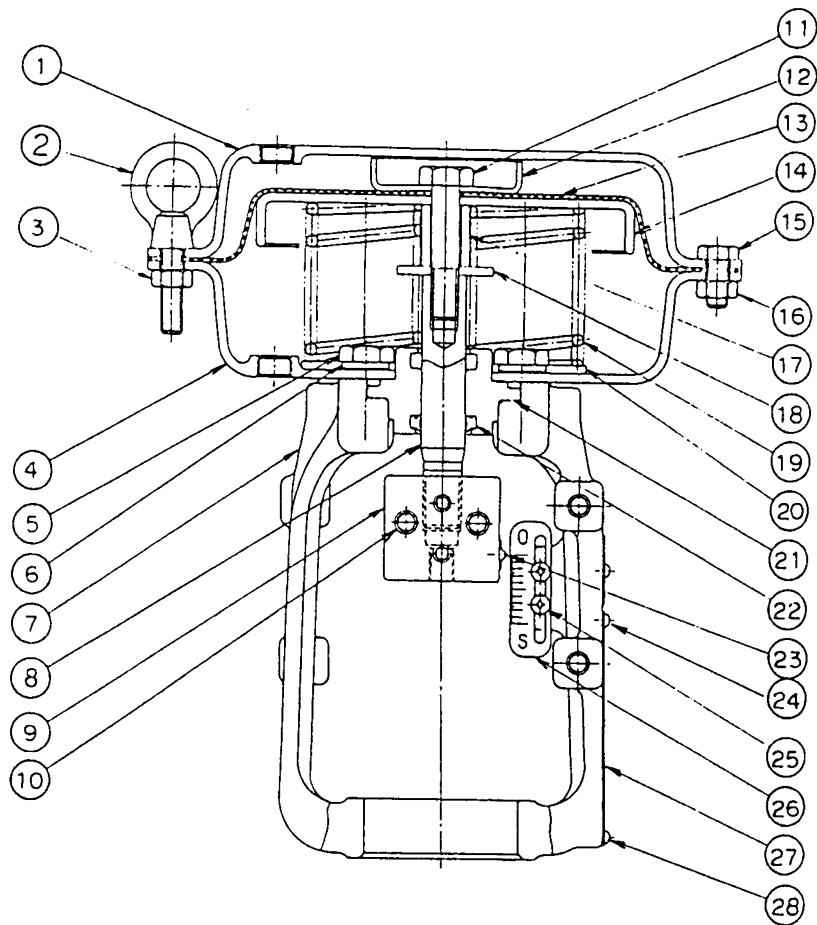

Table 4-1. Tightening Torques of Bolts and Nuts of Actuator

No.	Material	Bolt Size	Tightening Torque (N·m {kgf·cm})
1	S30C	M10	20 to 22 {200 to 220}
2	S30C	M10	27 to 33 {270 to 330}
3	$\frac{S20C}{SUS304}$	M8	$\frac{13 \text{ to } 16 \{135 \text{ to } 165\}}{15 \text{ to } 19 \{150 \text{ to } 195\}}$
4	SUS304	M8	15 to 19 {150 to 195}
5	$\frac{S20C}{SUS304}$	M8	$\frac{14 \text{ to } 18 \{145 \text{ to } 180\}}{16 \text{ to } 21 \{160 \text{ to } 210\}}$

Note 1: Fix the rain cap of the reverse type of actuator as follows: Drive the cap into the diaphragm case until the shoulder (brim) of the cap is brought into contact with the diaphragm case and then drive the cap further into the diaphragm case by half of a turn.



No.	Parts Name
1	DIAPHRAGM CASE (TOP)
2	EYEBOLT
3	NUT
4	DIAPHRAGM CASE (BOTTOM)
5	BOLT
6	WASHER
7	YOKE
8	ROD
9	STEM CONNECTOR
10	STEM CONNECTOR BOLT
11	CENTER BOLT
12	DIAPHRAGM RETAINER
13	DIAPHRAGM
14	DIAPHRAGM PLATE
15	BOLT

No.	Parts Name
16	NUT
17	STOPPER COLLAR
18	STOPPER RING
19	SPRING
20	SPRING PLATE
21	BEARING
22	DUST SEAL
23	POINTER
24	DRIVE SCREW
25	TRUSS SCREW
26	SCALE PLATE
27	NAMEPLATE
28	DRIVE SCREW

Fig. 4-7. Model HA1 Actuator (Direct Action Type)

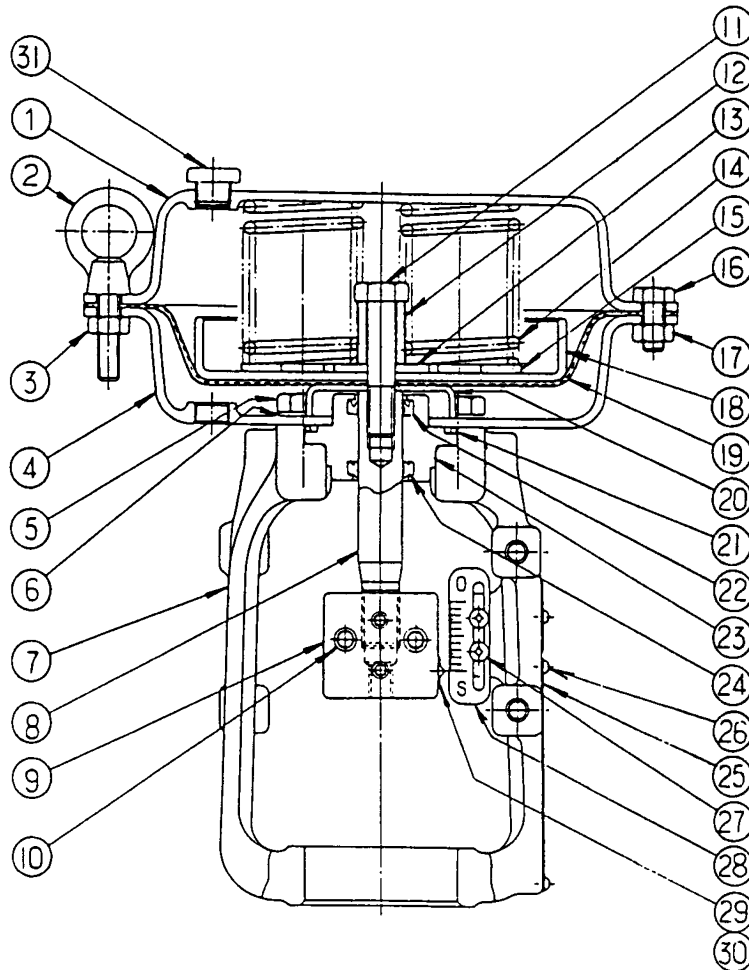

No.	Parts Name
1	DIAPHRAGM CASE (TOP)
2	EYEBOLT
3	NUT
4	DIAPHRAGM CASE (BOTTOM)
5	BOLT
6	SEAL WASHER
7	YOKE
8	ROD
9	STEM CONNECTOR
10	STEM CONNECTOR BOLT
11	CENTER BOLT
12	STOPPER COLLAR
13	STOPPER RING
14	SPRING
15	SPRING PLATE
16	BOLT
17	NUT
18	DIAPHRAGM PLATE

No.	Parts Name
19	DIAPHRAGM
20	DIAPHRAGM RETAINER
21	O-RING
22	PACKING FOR ROD
23	BEARING
24	DUST SEAL
25	NAMEPLATE
26	DRIVE SCREW
27	TRUSS SCREW
28	SCALE PLATE
29	POINTER
30	DRIVE SCREW
31	RAIN CAP AND O-RING

Fig. 4-8. Model HA1 Actuator (Reverse Action Type)

4.2 Disassembly and Assembly of Model HA2, HA3, or HA4 Actuator

Disassembly Procedure

(a) Direct Action Type

- (1) Disconnect the air piping and detach the accessories from the actuator.
- (2) Remove the stem connector, pointer and lock nut. (See Fig. 4-1.)
- (3) Remove the clamping-bolts (except the pair of eyebolts) of the diaphragm case.
- (4) Loosen evenly and alternately the pair of eyebolts. (The initial setting of the springs is done by these eyebolts.)
- (5) Remove the diaphragm case. Pull out upward the actuator rod together with the diaphragm.
- (6) Take out the springs.

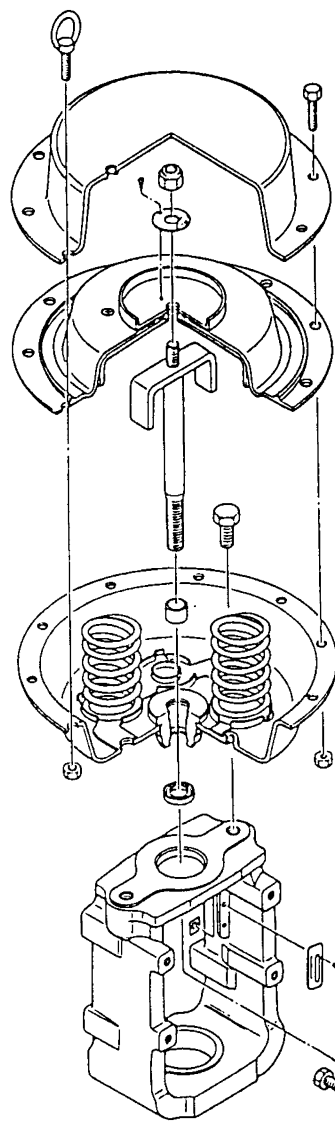

Fig. 4-9. HA2D or HA3D Actuator

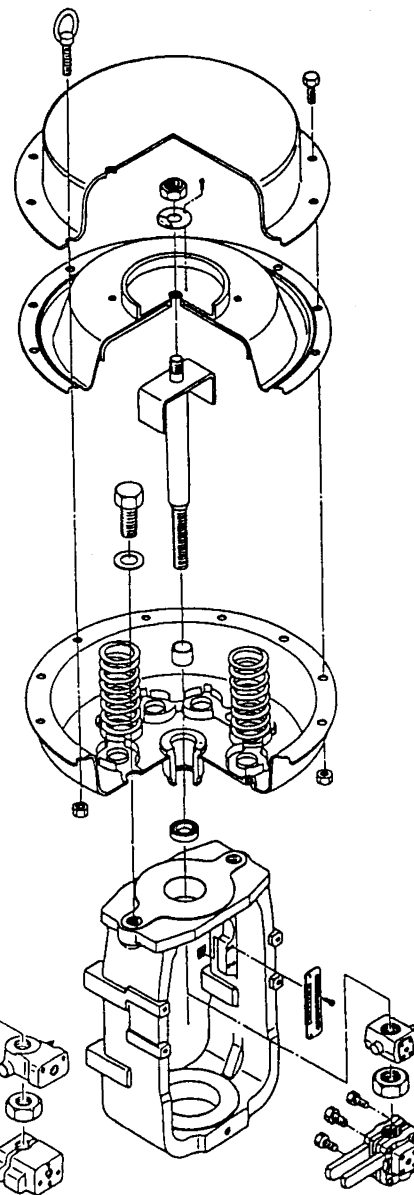

Fig. 4-10. HA4D Actuator

(b) Reverse Action Type

- (1) Disconnect the air piping and detach other external items from the actuator.
- (2) Remove the stem connector, pointer and lock nut. (See Fig. 4-1.)
- (3) Remove the clamping-bolts (except the pair of eyebolts) of the diaphragm case.
- (4) Loosen evenly and alternately the pair of eyebolts. (The initial setting of the springs is done by these eyebolts.)
- (5) Remove the diaphragm case. Take out the springs.
- (6) Pull out upward the actuator rod together with the diaphragm.

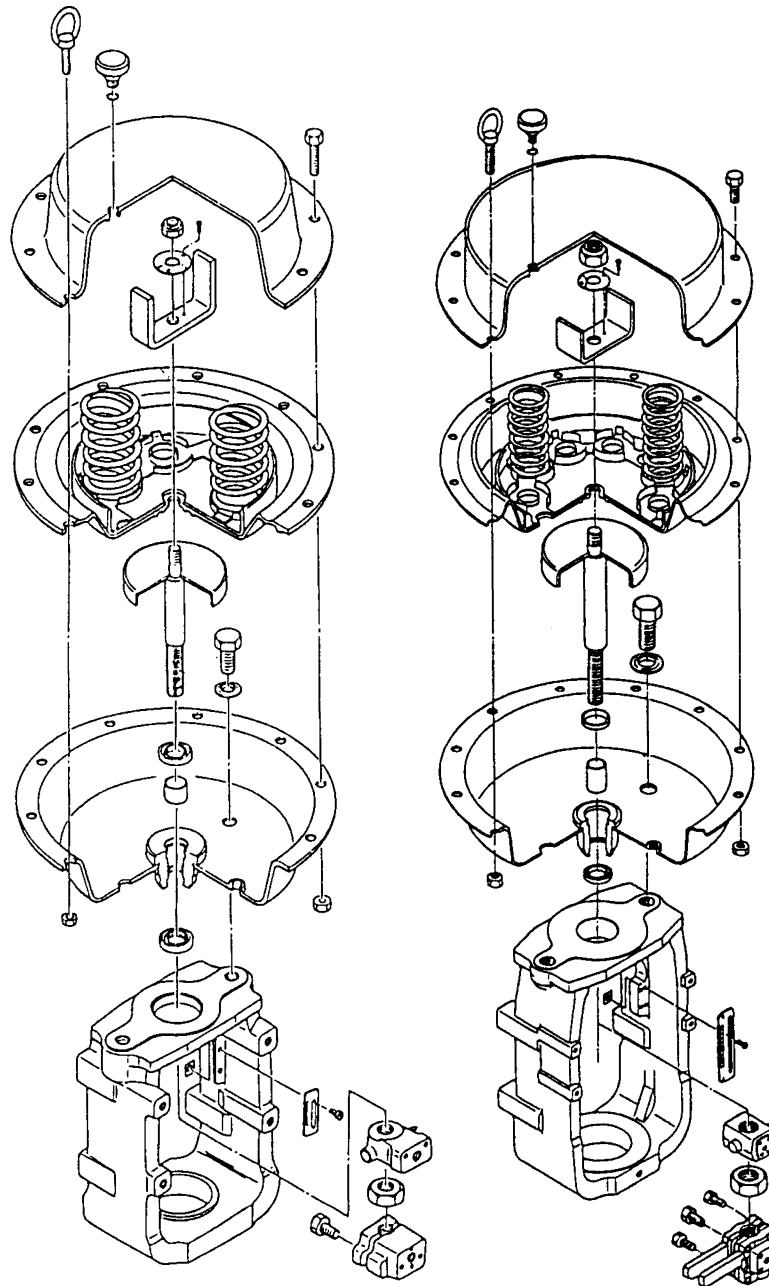

Fig. 4-11. HA2R or HA3R Actuator

Fig. 4-12. HA4R Actuator

Assembly Procedure

Before assembly, check the parts for scrapes, damage, deformation, peeling off of paint, and other abnormality. To assemble the actuator, proceed as follows:

(a) Direct Action Type

- (1) Fix the bottom diaphragm case and yoke with the bolts. (For Models HA2D and HA3D, install the diaphragm case and spring plate together.)
- (2) Install the springs on the spring plate. The quantities of springs are as follows:
HA2 4 springs
HA3, HA4 8 springs

Except particular models as follows:

HA2, 38 mm stroke,
80 – 240 kPa {0.8 – 2.4 kgf/cm²}..... Total 8 springs (with double springs)

HA3, 50 mm stroke,
80 – 240 kPa {0.8 – 2.4 kgf/cm²}..... Total 16 springs (with double springs)

HA4, 75 mm stroke,
80 – 240 kPa {0.8 – 2.4 kgf/cm²}..... Total 16 springs (with double springs)

- (3) Insert the actuator rod (to which the diaphragm is connected) into the bushing, exercising care not to damage the bushing inside surface or dust seal with the threaded section of the rod. (For example, cover the threaded section with adhesive tape to prevent damaging the bushing.) Set the stopper in parallel with the yoke.
- (4) Place the top diaphragm case and fix it with the pair of eyebolts.

- Notes:
- Set the air piping connection port in the location shown in the illustration. (Fig. 4-13)
 - Tighten the pair of eyebolts uniformly by tightening them alternately. The initial setting of the springs is complete by tightening of these eyebolts.

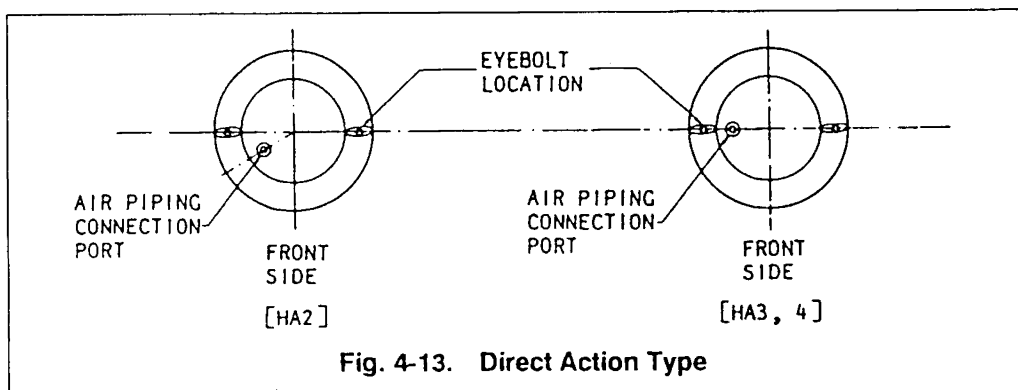

- (5) Clamp the diaphragm case with other clamping-bolts than the pair of eyebolts.
- (6) Install the pointer, secure the lock nut, and install the stem connector. (Connect the air pipe to the air piping connection port of the top diaphragm case.)
- (7) After the assembly is complete as above, check the following.
 1. Applying an air pressure of 490 kPa {5 kgf/cm²} via the air piping connection port of the top diaphragm case, check the diaphragm periphery for air leak by using soapsuds.
 2. Check that the actuator smoothly operates for its full stroke.

Note: Check this operation by operating the actuator as an independent unit.

(b) Reverse Action Type

- (1) Fix the bottom diaphragm case and yoke with the bolts.
- (2) Insert the actuator rod (to which the diaphragm is connected) into the bushing, exercising care not to damage the bushing inside surface or dust seal with the thread section of the rod. (For example, cover the threaded section with adhesive tape to prevent damaging the bushing.)
- (3) Make the stopper (in the diaphragm plate) in parallel with the yoke by turning the rod.
- (4) Install the springs on the spring plate. The quantities of springs are as follows:

HA2 4 springs

HA3, HA4 8 springs

Except particular models as follows:

HA2, 38 mm stroke,
80 – 240 kPa {0.8 – 2.4 kgf/cm²}..... Total 8 springs (with double springs)

HA3, 50 mm stroke,
80 – 240 kPa {0.8 – 2.4 kgf/cm²}..... Total 16 springs (with double springs)

HA4, 75 mm stroke,
80 – 240 kPa {0.8 – 2.4 kgf/cm²}..... Total 16 springs (with double springs)

- (5) Place the top diaphragm case and fix it with the pair of eyebolts. Set the air vent hole in the location shown in the illustration (Fig. 4-14). Uniformly and alternately tighten the eyebolts. The initial setting of the springs is complete by tightening of these eyebolts.

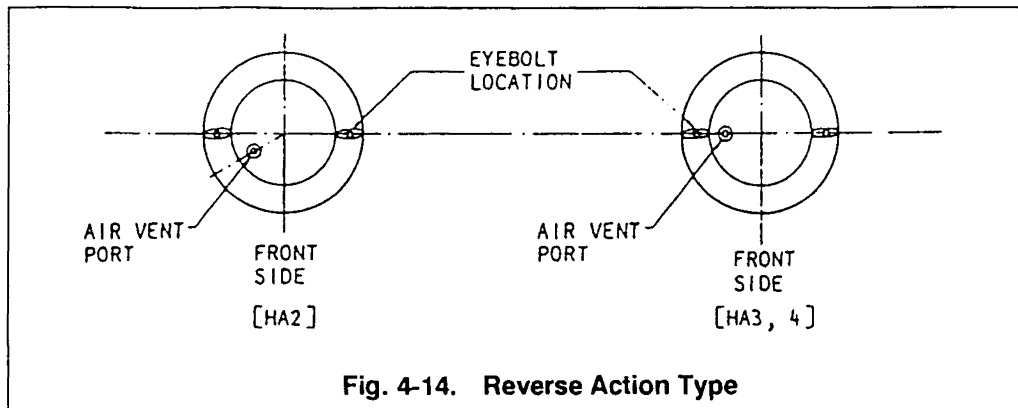

Fig. 4-14. Reverse Action Type

- (6) Clamp the diaphragm case with other clamping-bolts than the pair of eyebolts.
- (7) Install the pointer, secure the lock nut, and install the stem connector.
- (8) Install the rain cap on the air vent port.
- (9) Connect the air pipe to the air piping connection port of the bottom diaphragm case.
- (10) After the assembly is complete as above, check the following.
 1. Applying an air pressure of 490 kPa { 5 kgf/cm² } via the air piping connection port of the bottom diaphragm case, check the diaphragm periphery for air leak by using soapsuds.
 2. Check that the actuator smoothly operates for its full stroke.

Note: Check this operation by operating the actuator as an independent unit.

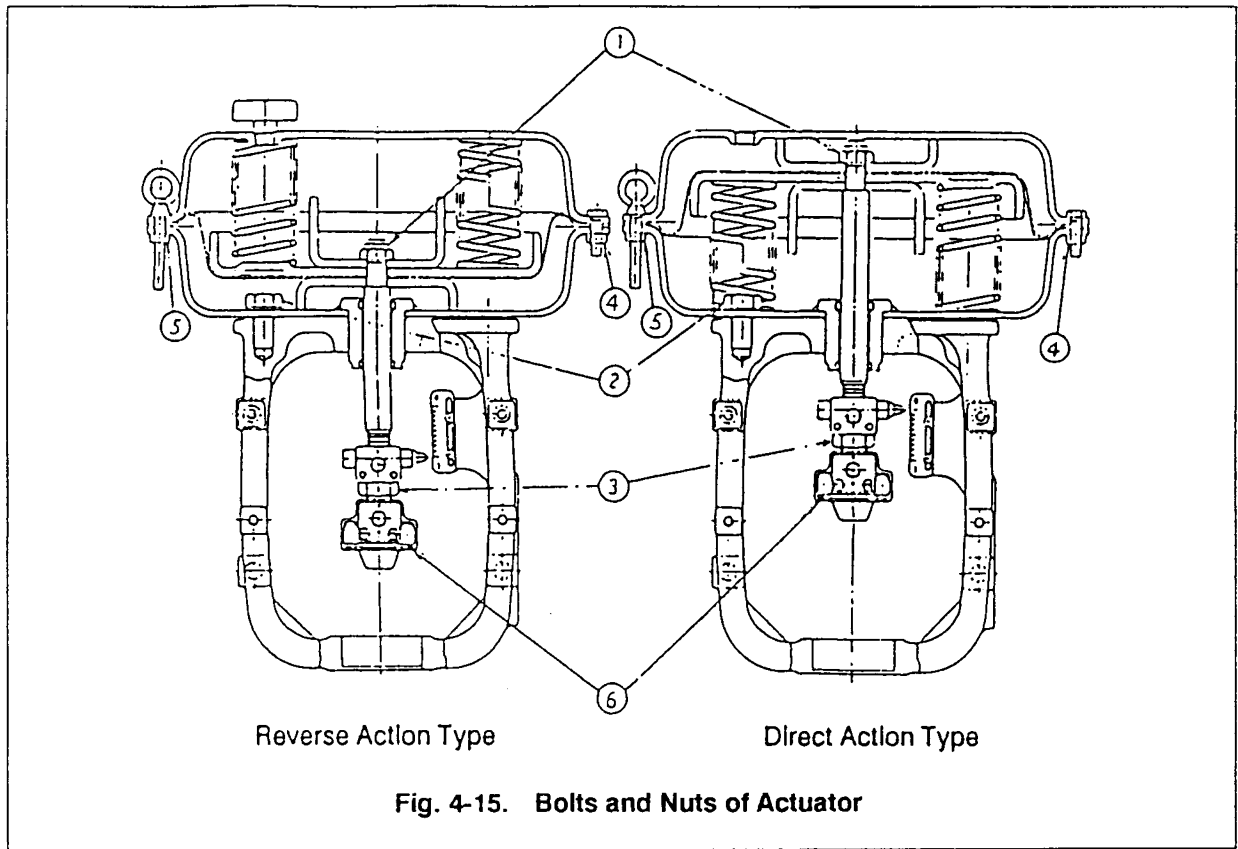
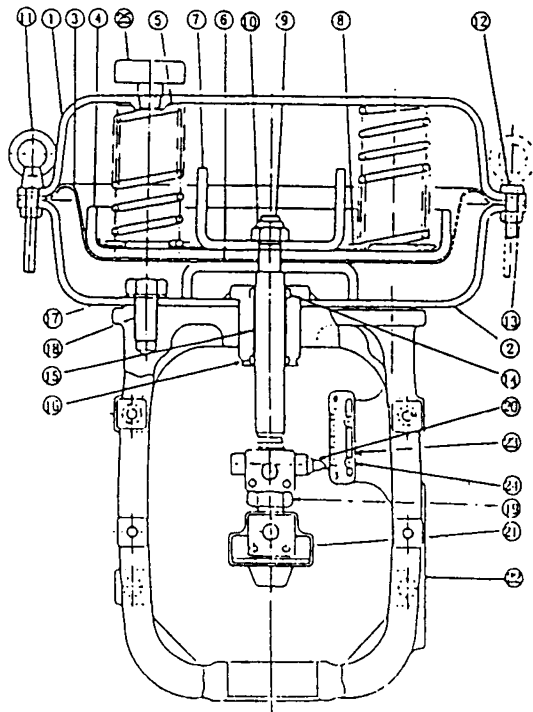

Table 4-2. Tightening Torques of Bolts and Nuts of Actuator

Unit: N·m {kgf·cm}

No.	Materials	For HA2		For HA3		For HA4	
		Material	Torque	Material	Torque	Material	Torque
1	SK5 S45C	M10	37 {370}	M14	100 {1,050}	M20	310 {3,170}
2	S30C	M12	42 {420}	M16	100 {1,050}	M24	360 {3,600}
3	S20C	M14	69 {690}	M18	140 {1,450}	M30	700 {7,160}
4	S20C	M8	16 {160}	M8	16 {160}	M12	42 {420}
5	SUS304	M8	18 {185}	M8	18 {185}	M12	63 {630}
6	S30C	M10	37 {375}	M10	37 {375}	M12	42 {420}
	SUS304		56 {560}		56 {560}		63 {630}



Reverse Action Type
(Model HAQR)

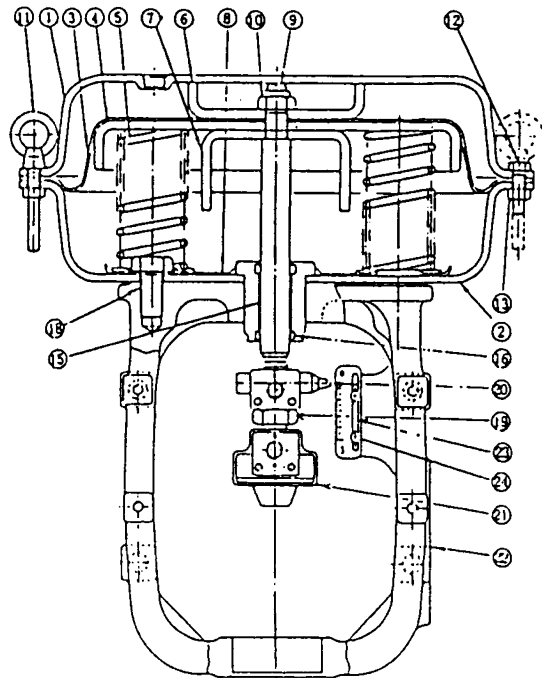

Direct Action Type
(Model HAQD)

Parts No.	Parts Name	Parts No.	Parts Name	Parts No.	Parts Name
1	NUT	12	YOKE	23	WASHER
2	DIAPHRAGM CASE (TOP)	13	STEM CONNECTOR	24	PACKING
3	DIAPHRAGM	14	BOLT	25	ROD
4	EYE BOLT	15	DIAPHRAGM RETAINER	26	LOCK NUT
5	NUT	16	STOPPER	27	TRUS SCREW (WASHER, NUT)
6	BOLT	17	DIAPHRAGM PLATE	28	SCALE PLATE
7	DIAPHRAGM CASE (BOTTOM)	18	COIL SPRING	29	SCREW
8	BUSHING	19	BOLT	30	NAMEPLATE
9	BEARING	20	NUT	31	CAP
10	DUST SEAL	21	SPRING PLATE	32	O-RING
11	POINTER	22	BOLT	33	WASHER
				34	TAPPING SCREW

Fig. 4-16. Cut View of Actuator

5. DIMENSIONS, WEIGHT AND OUTPUT OF HL

5.1 HA Multismotors

Model No.	Stroke (mm)	Dimensions (mm)							Nominal diaphragm area (cm ²)	Maximum diaphragm chamber capacity (cm ³)	Weight (kg)
		L	H	φd	t	K	φB	B			
HA1D HA1R	14.3 25.0	119 105 120 95	260	56	22	M9x1	218	230	160	850	8
HA2D HA2R	14.3 25.0 38.0	121 103 122 95 142 102	334	56	22	M9x1	267	281	310	1100	15
HA3D HA3R	25.0 38.0 50.0	144 113 144 102 196 139	407	65	26	M12x1.25	350	363	550	2800	31
HA4D HA4R	38.0 50.0 75.0	214 172 226 172 251 172	612	90	35	M18x1.5	470	520	950	10000	68

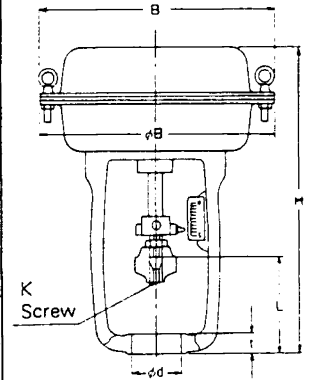

Fig. 5-1. Dimensions of HA Multismotor

Note: 1) Dimension L is as with air pressure 0 kPa (0 kg/cm²).

2) The model numbers and L dimensions are listed with those of the direct action in the top row and those of the reverse action in the bottom row.

5.2 Multismotor with Side-mounted Handwheel

Model No.	Stroke (mm)	Dimensions (mm)						Max. operating force required at handle (kg)	Weight (kg)
		A	φB	B	C	φD	H		
HA2D HA2R	14.3 25.0 38.0	289	267	281	37 57	200	334 354	19	25 26
HA3D HA3R	25.0 38.0 50.0	347	350	363	46 98	355	407 459	29	49 50
HA4D HA4R	38.0 50.0 75.0	476	470	520	114	570	612	46	120

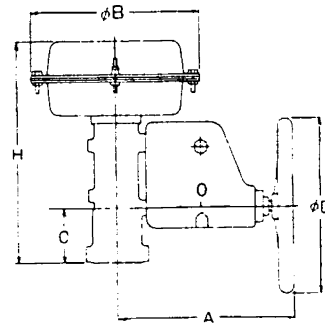

Fig. 5-2. Multismotor with Side-mounted Handwheel

Notes 1) Dimension B is as shown in Figure 1-1.

2) Model HA1 cannot be provided with the side-mounted handwheel. Only top-mounted handwheel is available.

5.3 Multismotor with Top-mounted Handwheel

Model No.	Stroke (mm)	Dimensions (mm)				Max. operating force required at handle (kg)	Weight (kg)
		φB	B	φD	H		
HA1D HA1R	14.3 25.0	218	230	140	410	16	11
HA2D HA2R	14.3 25.0 38.0	267	281	200	D: 575 R: 558 D: 595 R: 591	19	23 24
HA3D HA3R	25.0 38.0 50.0	350	363	355	D: 694 R: 682 746	26	46 47
HA4D HA4R	38.0 50.0 75.0	470	520	570	1010	41	110

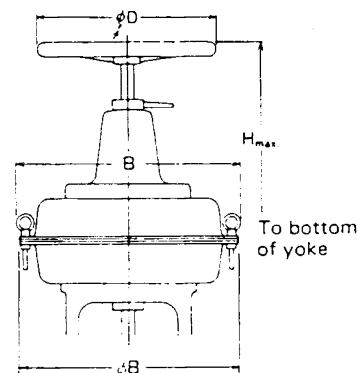

Fig. 5-3. Multismotor with Top-mounted Handwheel

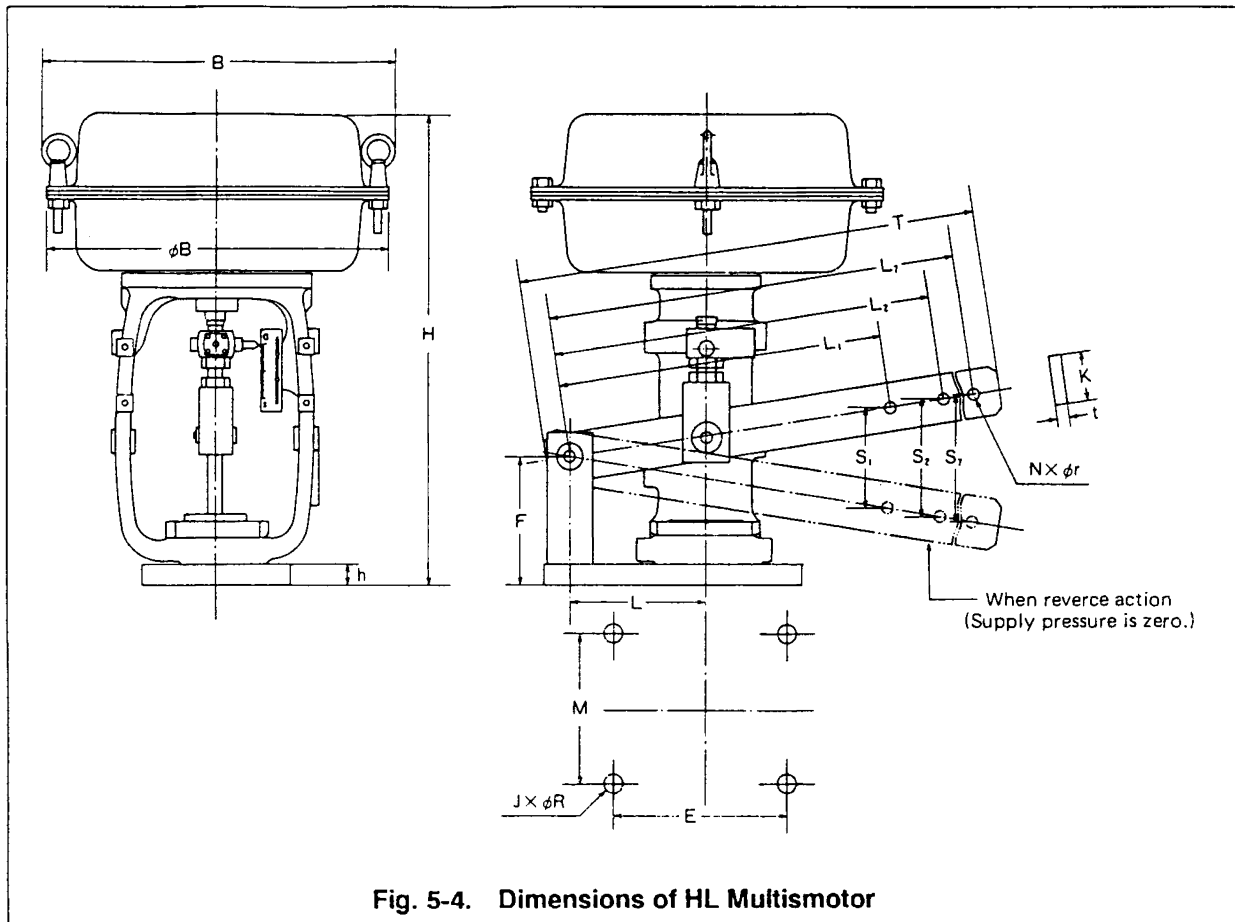

Fig. 5-4. Dimensions of HL Multismotor

5.4 Dimensions of HL Multismotors

Model No.	Stroke (mm)	Dimensions (mm)											
		ϕB	B	H	F	h	K	t	T	JX ϕR	NX ϕr	E	M
HL2D,R	25	267	$\phi 267$	349	80	16	38	12	520	4X13.5	7X10	120	100
HL3D,R	50	350	$\phi 350$	481	130	22	50	16	710	4X13.5	6X15	140	120
HL4D,R	75	470	$\phi 470$	637	160	25	65	19	860	4X22.0	6X20	140	160

Model No.	Dimensions (mm)																	Nominal diaphragm area (cm ²)	Maximum diaphragm chamber capacity (cm ³)	Weight (kg)
	S	L	S ₁	L ₁	S ₂	L ₂	S ₃	L ₃	S ₄	L ₄	S ₅	L ₅	S ₆	L ₆	S ₇	L ₇				
HL2D,R	25	100	60	240	70	280	80	320	90	360	100	400	110	440	120	480	310	1100	22	
HL3D,R	50	130	127	330	152	396	178	462	203	528	228	594	254	660	-	-	550	3400	45	
HL4D,R	75	160	188	400	225	480	263	560	300	640	338	720	375	800	-	-	950	10000	95	

5.5 Dimensions of HL Multismotors with Top-mounted Handwheel

Model No.	Stroke (mm)	Dimensions (mm)				Maximum required operating force N (kgf)	Weight (kg)
		ϕB	B	ϕD	Hmax		
HL2D,R	25	267	281	280	573	140 (14)	30
HL3D,R	50	350	363	355	743	260 (26)	60
HL4D,R	75	470	520	570	1008	410 (41)	137

Drawings: Refer to 5-3.

6. DIRECT/REVERSE ACTION TYPE CONVERSION AND SPRING RANGE CHANGE OF ACTUATOR

6.1 Direct/Reverse Action Change

As a general rule it is most recommendable to prepare separately the direct type and reverse type of actuators and not to convert actuators into different types. However, when it has become unavoidable to convert actuators into other types, conversions may be done by using the parts mentioned below (Table 6-1 and Table 6-2). The parts marked "+" are the ones which are additionally needed and those marked "-" are ones which are not used.

Table 6-1. To Convert the Direct Action Type into the Reverse Action Type

HA1D → HA1R		
Parts name	Q'ty	
Seal washer	+ 4	80352967-006
Rod packing	+ 1	82521067-101
Rain cap	+ 1	82664804-101
Washer	- 4	82592130-401
"O" ring	+ 1	82592225-396

HA2D → HA2R			
Parts name	Q'ty	For stroke 14.3 mm, 25 mm	For stroke 38 mm
Seal washers	+ 4	82521069-101	82521069-101
Rod packing	+ 1	82521067-101	82521067-101
Rod unit	+ 1	82521431-101 (14.3 mm) 82521431-102 (25 mm)	82521431-103
Rain cap	+ 1	82592147-101	82592147-101
Rod	(- 1)	82521427-101 (14.3 mm) 82521427-102 (25 mm)	82521427-103

HA3D → HA3R				
Parts name	Q'ty	For stroke 14.3 mm	For stroke 25 mm, 38 mm	For stroke 50 mm
Seal washers	+ 2	82521069-102	82521069-102	82521069-102
Rod packing	+ 1	82521067-102	82521067-102	82521067-102
Rod unit	+ 1	82521431-201	82521063-103 (25 mm) 82521063-104 (38 mm)	82521431-204
Rain cap	+ 1	82592147-101	82592147-101	82592147-101
Rod	(- 1)	82521428-101	82521428-102 (25 mm) 82521428-103 (38 mm)	82521428-104

HA4D → HA4R			
Parts name	Q'ty	For stroke 25 mm	For stroke 38 mm, 50 mm, 75 mm
Seal washers	+ 2	82521069-103	82521069-103
Rod packing	+ 1	82521067-103	82521067-103
Rod unit	+ 1	82521431-302	82521431-303
Rod unit	(- 1)	82521429-102	82521429-103 (38 mm) 82521429-104 (50 mm) 82521429-105 (75 mm)
Rain cap	+ 1	82592147-101	82592147-101
Flat washers	(- 2)	82592131-201	82592131-201

Table 6-2. To Convert the Reverse Action Type into the Direct Action Type

HA1R → HA1D		
Parts name	Q'ty	
Seal washer	- 4	80352967-006
Rod packing	- 1	82521067-101
Rain cap	- 1	82664804-101
Washer	+ 4	82592130-401
"O" ring	- 1	82592225-396

HA2R → HA2D			
Parts name	Q'ty	For stroke 14.3 mm, 25 mm	For stroke 38 mm
Seal washers	(- 2)	82521069-101	82521069-101
Rod packing	(- 1)	82521067-101	82521067-101
Rod unit	+ 1	82521427-101 (14.3 mm) 82521427-102 (25 mm)	82521427-103
Rod unit	(- 1)	82521431-101 (14.3 mm) 82521431-102 (25 mm)	82521431-103
Rain cap	(- 1)	82592147-101	82592147-101

HA3R → HA3D				
Parts name	Q'ty	For stroke 14.3 mm	For stroke 25 mm, 38 mm	For stroke 50 mm
Seal washers	(- 2)	82521069-102	82521069-102	82521069-102
Rod packing	(- 1)	82521067-102	82521067-102	82521067-102
Rod unit	+ 1	82521428-101	82521428-102 (25 mm) 82521428-103 (38 mm)	82521428-104
Rod unit	(- 1)	82521431-201	82521431-202 (25 mm) 82521431-203 (38 mm)	82521431-204
Rain cap	(- 1)	82592147-101	82592147-101	82592147-101

HA4R → HA4D			
Parts name	Q'ty	For stroke 25 mm	For stroke 38 mm, 50 mm, 75 mm
Seal washers	(- 2)	82521069-103	82521069-103
Flat washers	+ 2	82592131-201	82592131-201
Rod packing	(- 1)	82521067-103	82521067-103
Rod unit	(- 1)	82521431-302	82521431-303
Rod unit	+ 1	82521429-102	82521429-103 (38 mm) 82521429-104 (50 mm) 82521429-105 (75 mm)
Rain cap	(- 1)	82592147-101	82592147-101

For the conversion procedure, refer to Section 4 "DISASSEMBLY AND ASSEMBLY."

6.2 Stroke And Range Spring Change

As a general rule it is most recommendable to prepare separate actuators for different strokes and spring ranges to avoid modifications. However, modifications can be done by using the parts mentioned below.

Of Models HA2 and HA3, there are two different diameters of bonnet connecting sections. For these models, note the following:

Of Model HA2, modification for change between rated stroke of 14.3 or 25 mm and that of 38 mm cannot be done.

Of Model HA3, modification for change between rated stroke of 25 or 38 mm and that of 50 mm cannot be done.

Table 6-3. Parts Required for Respective Stroke Ranges

Note: Spring force is equivalent to air pressure (kPa (kgf/cm²))

Actuator		HA1D, HA1R		
Parts name		Q'ty	Stroke 25 → 14.3 mm	Stroke 14.3 → 25 mm
Scale plate		1	82521348-101	82521343-101
Spring	20 – 98 {0.2 – 0.1}	4	82521340-101	82521340-104
	80 – 240 {0.8 – 2.4}	4	82521340-102	82521341-103
Center bolt		1	82521350-327	82521350-127
Stopper color		1	82521338-103	82521338-101
Rod unit		1	82521342-103	82521342-101

Actuator		HA2D, HA2R		
Parts name		Q'ty	Stroke 25 → 14.3 mm	Stroke 14.3 → 25 mm
Scale plate		1	80225032-164	80225037-164
Spring	20 – 98 {0.2 – 0.1}	4	82521205-101	82521205-103
	80 – 240 {0.8 – 2.4}	4	82521205-102	82521208-101
Rod unit	R (Reverse action)	1	82521431-101	82521431-102
	D (Direct action)	1	82521427-101	82521427-102

Actuator		HA3D, HA3R		
Parts name		Q'ty	Stroke 38 → 25 mm	Stroke 25 → 38 mm
Scale plate		1	80225037-164	80225039-164
Spring	20 – 98 {0.2 – 0.1}	8	82521206-101	82521206-103
	80 – 240 {0.8 – 2.4}	8	82521206-102	82521209-101
Rod unit	R (Reverse action)	1	82521431-202	82521431-203
	D (Direct action)	1	82521428-102	82521428-103

Actuator		HA4D → HA4R				
Parts name		Qty	Stroke 25 mm	Stroke 38 mm	Stroke 50 mm	Stroke 75 mm
Scale plate		1	80225037-164	80225039-164	80225041-164	80224425-164
Spring	20 – 98 {0.2 – 0.1}	8	82521244-104	82521207-101	82521207-102	82521210-103
	80 – 240 {0.8 – 2.4}	8	82521244-106	82521210-101	82521210-102	82521210-104* 82521210-105*
Rod unit	R (Reverse action)	1	82521429-102	82521429-103	82521429-104	82521429-105
	D (Direct action)	1	82521431-302	82521431-303	82521431-303	82521431-303

*: The quantity of springs is 8 sets, with 2 springs for each set, or total 16 springs.

Color Codes and Dimensions of the Springs of Model HA Actuators

The color codes and dimensions of the springs of Model HA Actuators are as shown in the following table. The color codes may help you confirm springs when disassembling and assembling actuators for modification or other purposes.

Table 6-4. Color Codes and Dimensions of Springs

Rated stroke	Model Range	(mm)			
		HA1	HA2	HA3	HA4
14.3	20 – 98 {0.2 – 1.0}	Red 64.6	Red 86	Yellow and Green 99.2	
	80 – 240 {0.8 – 2.4}	Blue 69.8	Blue 90	Red and Green 103.6	
25	20 – 98 {0.2 – 1.0}	Green 68.7	Yellow 91.4	Red 99.3	Yellow and Green 148.1
	80 – 240 {0.8 – 2.4}	Purple 78.8	Brown 99	Blue 107	Red and Green 155.3
38	20 – 98 {0.2 – 1.0}		Green 95	Yellow 102.9	Red 152.8
	80 – 240 {0.8 – 2.4}		Purple* 107	Brown 114.9	Blue 163.7
50	20 – 98 {0.2 – 1.0}			Green 106.5	Yellow 156.3
	80 – 240 {0.8 – 2.4}			Purple 122.2	Brown 170.6
75	20 – 98 {0.2 – 1.0}				Green 163.4
	80 – 240 {0.8 – 2.4}				Purple NOTE 1. 182, 186.7*

- Notes:
- * set is comprised of two springs.
 - "20 – 98" {0.2 – 1.0} and "80 – 240" {0.8 – 2.4} are spring forces corresponding to air pressures in the unit of kPa {kgf/cm²}.
 - The dimensions indicated in the Table 7.4 are free lengths of springs.

7. INSTRUCTIONS FOR TOP HANDWHEEL OF ACTUATOR

7.1 Model HA1 Actuator

7.1.1 Operating Instructions

To manually operate the actuator, refer to Fig. 7-1 and Fig. 7-2 and proceed as follows:

- (1) Loosen the lock nut of the handwheel and turn the handwheel in the direction indicated by the corresponding arrowhead mark.

As you turn the handwheel clockwise, the actuator stem moves downward regardless of whether the actuator is of the direct action type or reverse action type. The handwheel bears the "SHUT" mark to indicate that the valve is closed as the handwheel is turned clockwise and the "OPEN" mark to indicate that the valve is made open as the handwheel is turned counterclockwise.

- (2) For automatic operation of the actuator, fully raise the handwheel if the actuator is of the direct action type or fully lower the handwheel if the actuator is of reverse action type, and then tighten the lock nut to secure the handwheel in such position.

Precautions: If you forcefully turn the handwheel after it has reached the mechanical stop position, the valve stem may be damaged. Do not turn the handwheel with forces larger than 16 kgf at the outermost periphery of the handwheel.

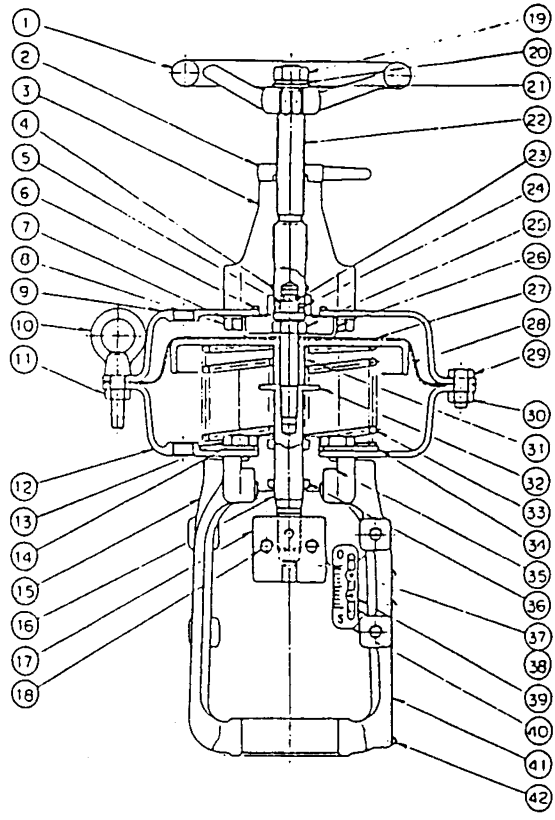

No.1	Parts Name
1	HANDWHEEL
2	LOCKNUT
3	HOUSING
4	O-RING
5	WASHER
6	O-RING
7	SEAL WASHER
8	BOLT
9	DIAPHRAGM CASE (TOP)
10	EYE-BOLT
11	NUT
12	DIAPHRAGM CAE (BOTTOM)
13	BOLT
14	WASHER
15	YOKE
16	ROD
17	STEM CONNECTOR
18	STEM CONNECTOR BOLT
19	NUT
20	SPRING WASHER
21	WASHER
22	SCREW SHAFT
23	SPRING PIN
24	BEARING

No.1	Parts Name
25	CENTER BOLT
26	DIAPHRAGM RETAINER
27	DIAPHRAGM
28	DAPHRAGM PLATE
29	BOLT
30	NUT
31	STOPPER COLOR
32	STOPPER RING
33	SPRING
34	SPRING PLATE
35	BEARING
36	DUST SEAL
37	POINTER
38	DRIVE SCREW
39	TRUSS SCREW
40	SCALE PLATE
41	NAMEPLATE
42	DRIVE SCREW

Fig. 7-1. Model HA1 Actuator with Top Handwheel (Direct Action Type)

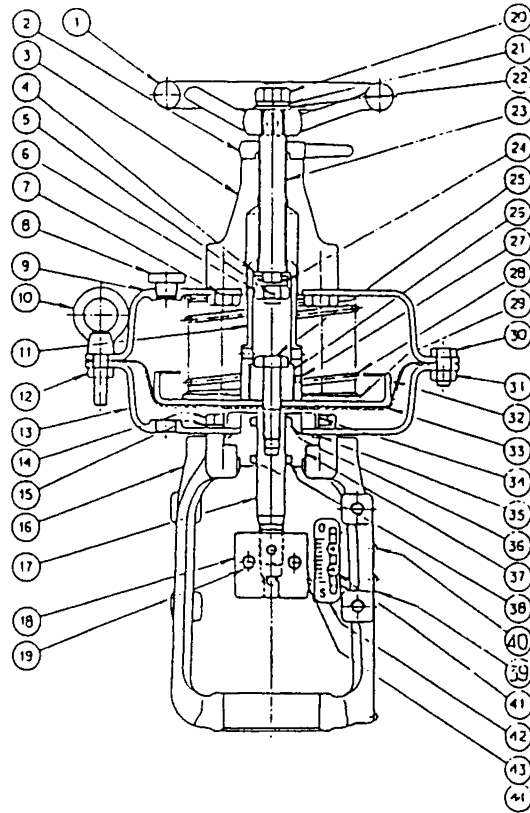

No.1	Parts Name
1	HANDWHEEL
2	LOCKNUT
3	HOUSING
4	WASHER
5	SPRING PIN
6	NUT
7	BOLT
8	CAP AND O-RING
9	DIAPHRAGM CASE (TOP)
10	EYE-BOLT
11	BEARING CASE
12	NUT
13	DIAPHRAGM CASE (BOTTOM)
14	BOLT
15	SEAL WASHER
16	YOKE
17	ROD
18	STEM CONNECTOR
19	STEM CONNECTOR BOLT
20	NUT
21	SPRING WASHER
22	WASHER
23	SCREW SHAFT

No.1	Parts Name
24	BEARING
25	CENTER BOLT
26	DIAPHRAGM RETAINER
27	SCREW
28	SPRING
29	SPRING PLATE
30	BOLT
31	NUT
32	DIAPHRAGM PLATE
33	DIAPHRAGM
34	DIAPHRAGM RETAINER
35	O-RING
36	ROD PACKING
37	BEARING
38	DUST SEAL
39	NAMEPLATE
40	DRIVE SCREW
41	TRUSS SCREW
42	SCALE PLATE
43	POINTER
44	DRIVE SCREW

Fig. 7-2. Model HA1 Actuator with Top Handwheel (Reverse Action Type)

7.1.2 Disassembly and Assembly of Top Handwheel

To disassemble or assemble the top handwheel, refer to Fig. 7-1 through 7-4 and proceed as described in this section. For disassembly work, keep the actuator in the vertical attitude.

(a) Direct Action Type

- (1) Disconnect the air piping.
- (2) Set the handwheel shaft in the automatic operation position (fully raise the handwheel shaft).
- (3) Remove the top diaphragm case. When doing this, loosen the pair of eyebolts uniformly and alternately, after removing all other clamping-bolts of the diaphragm case.
- (4) Sufficiently insert the handwheel shaft by turning it and then remove the handwheel and the lock nut. Insert the shaft further and then remove the screw shaft from the housing.
- (5) Remove the O-ring.

To assemble the top handwheel, follow the disassembly procedure in the reverse order.

(b) Reverse Action Type

- (1) Disconnect the air piping.
- (2) Set the handwheel shaft in the automatic operation position (fully lower the handwheel shaft).
- (3) Remove the handwheel and the lock nut. Insert the shaft into the housing by means of the threading until the threaded sections are disengaged.
- (4) Remove the top diaphragm case. When doing this, loosen the pair of eyebolts uniformly and alternately, after removing all other clamping-bolts of the diaphragm case.
- (5) Remove the housing by loosening its clamping-screw.
- (6) Remove the setscrew and then remove the bearing case.
- (7) Remove the spring pin and then remove the castle nut.
- (8) Remove the bearing retainer and then remove the bearing.

To assemble the top handwheel, follow the disassembly procedure in the reverse order.

(c) Inspection After Assembly

- (1) Check that the handwheel turns smoothly for the full stroke.
- (2) For the direct action type of actuator, check by means of soapsuds that there is no air leak from the connecting section of the top diaphragm case.

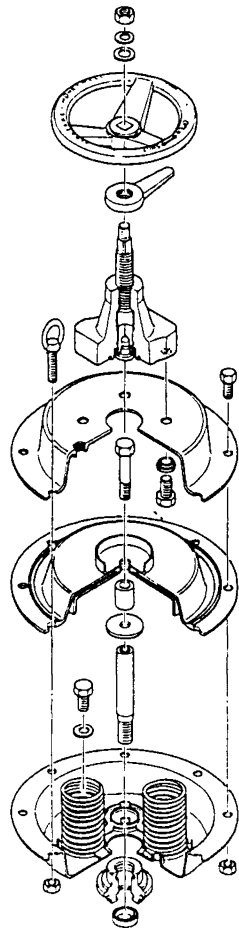

Fig. 7-3. Model HA1 Direct Action Type

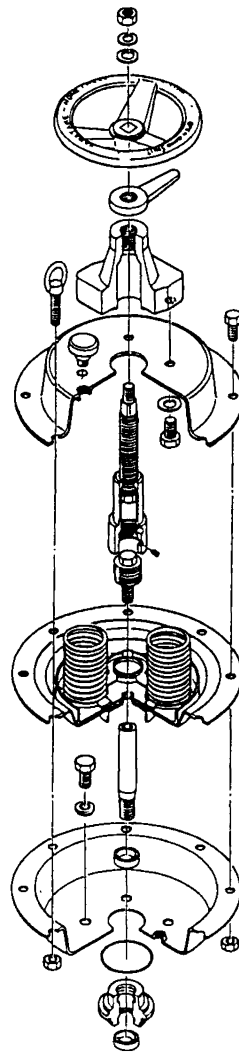

Fig. 7-4. Model HA1 Reverse Action Type

7.2 Model HA2, HA3, or HA4 Actuator

7.2.1 Operating Instructions

To manually operate the actuator, refer to Fig. 7-5 through Fig. 7-8 and proceed as follows:

- (1) First, loosen the lock nut (which has a bar-shape handle and which locks the handwheel) and turn the handwheel in the direction indicated by the corresponding arrowhead mark.

As you turn the handwheel clockwise, the actuator stem moves downward regardless of whether the actuator is of the direct action type or reverse action type. The handwheel bears the "SHUT" mark to indicate that the valve is closed as the handwheel is turned clockwise and the "OPEN" mark to indicate that the valve is made open as the handwheel is turned counterclockwise.

- (2) For automatic operation of the actuator, fully raise the handwheel if the actuator is of the direct action type or fully lower the handwheel if the actuator is of the reverse action type, and then tighten the lock nut to secure the handwheel in such position.

Precautions: If you forcefully turn the handwheel after it has reached the mechanical stop position, the valve stem may be damaged. Do not turn the handwheel with forces larger than the below-mentioned limits.

Model HA2: 190 N {19 kgf}

Model HA3: 260 N {26 kgf}

Model HA4: 410 N {41 kgf}
(at the outermost periphery of the handwheel)

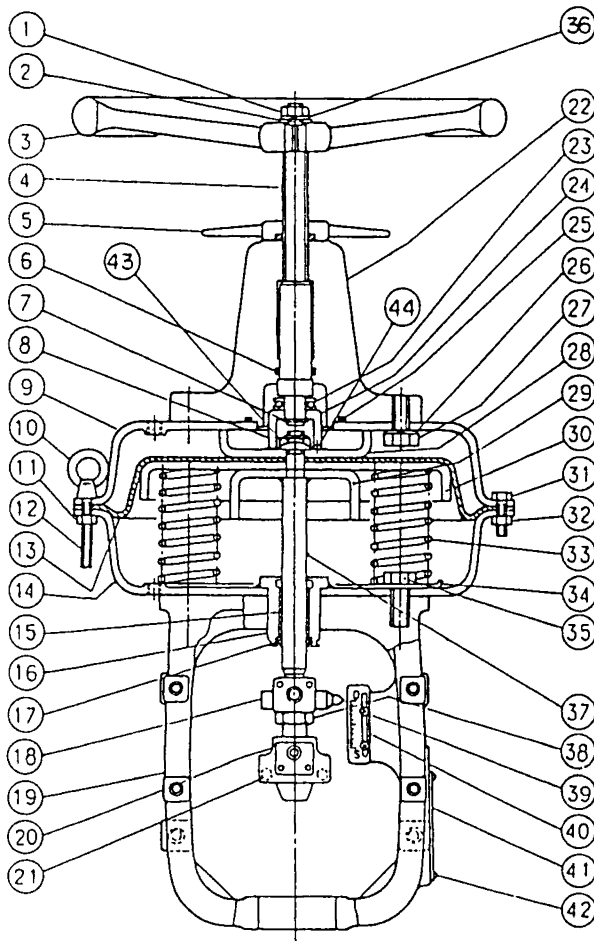

No.1	Parts Name
1	NUT
2	WASHER
3	HANDWHEEL
4	SCREW SHAFT
5	LOCK NUT
6	O-RING
7	COTTER
8	NUT
9	DIAPHRAGM CASE (TOP)
10	EYEBOLT
11	NUT
12	THROUGH BOLT
13	DIAPHRAGM
14	DIAPHRAGM CASE (BOTTOM)
15	BUSHING
16	BEARING
17	DUST SEAL
18	POINTER
19	YOKE
20	STEM CONNECTOR
21	STEM CONNECTOR BOLT
22	HOUSING
23	BEARING
24	SPRING RETAINER
25	O-RING
26	SEAL WASHER
27	BOLT
28	DIAPHRAGM RETAINER
29	STOPPER
30	DIAPHRAGM PLATE
31	BOLT
32	NUT
33	COMPRESSED COIL SPRING
34	SPRING PLATE
35	BOLT
36	SPRING WASHER
37	ROD
38	LOCK NUT
39	TRUSS SCREW, SPRING WASHER NUT, OR SPEED NUT
40	SCALE
41	NAMEPLATE
42	DRIVE SCREW
43	WASHER
44	TAPPING SCREW

Fig. 7-5. Model HA2/3 Actuator with Top Handwheel (Direct Action Type)

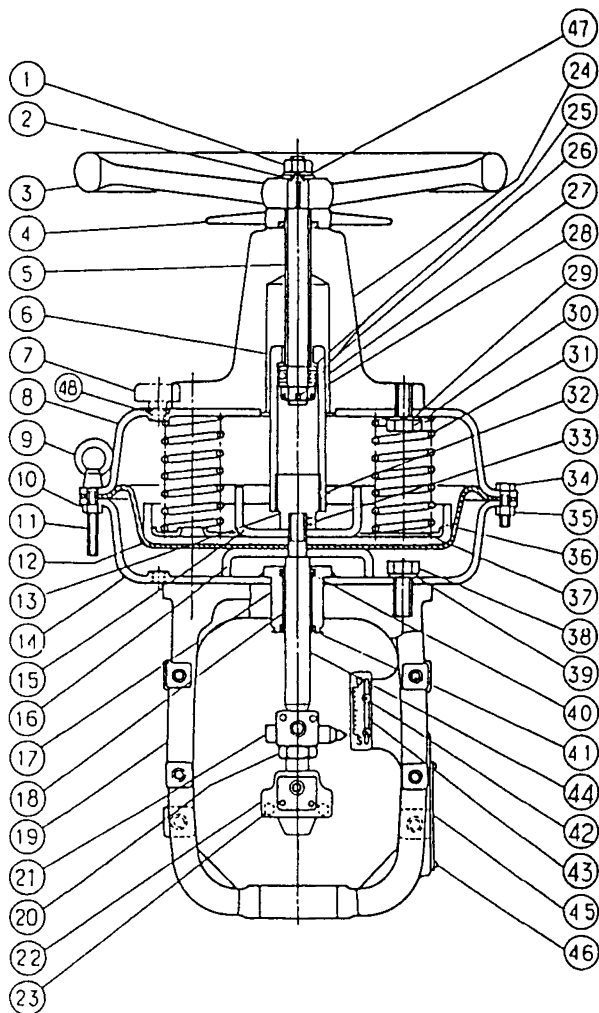

No.1	Parts Name
1	NUT
2	WASHER
3	HANDWHEEL
4	LOCK NUT
5	SCREW SHAFT
6	BEARING CASE
7	CAP
8	DIAPHRAGM CASE (TOP)
9	EYEBOLT
10	NUT
11	THROUGH BOLT
12	DIAPHRAGM
13	CONNECTOR
14	DIAPHRAGM CASE (BOTTOM)
15	STOPPER
16	DIAPHRAGM RETAINER
17	BEARING
18	BUSHING
19	YOKE
20	LOCK NUT
21	POINTER
22	STEM CONNECTOR
23	STEM CONNECTOR BOLT
24	HOUSING
25	BEARING WASHER
26	BEARING
27	COTTER PIN
28	CASTLE NUT
29	SEAL WASHER
30	BOLT
31	COMPRESSED COIL SPRING
32	SETSCREW
33	SETSCREW
34	BOLT
35	NUT
36	DIAPHRAGM PLATE
37	SPRING PLATE
38	BOLT
39	SEAL WASHER
40	PACKING FOR ROD
41	DUST SEAL
42	TRUSS SCREW, SPRING WASHER NUT, OR SPEED NUT
43	SCALE
44	ROD
45	NAMEPLATE
46	DRIVE SCREW
47	SPRING WASHER
48	O-RING

Fig. 7-6. Model HA2/3 Actuator with Top Handwheel (Reverse Action Type)

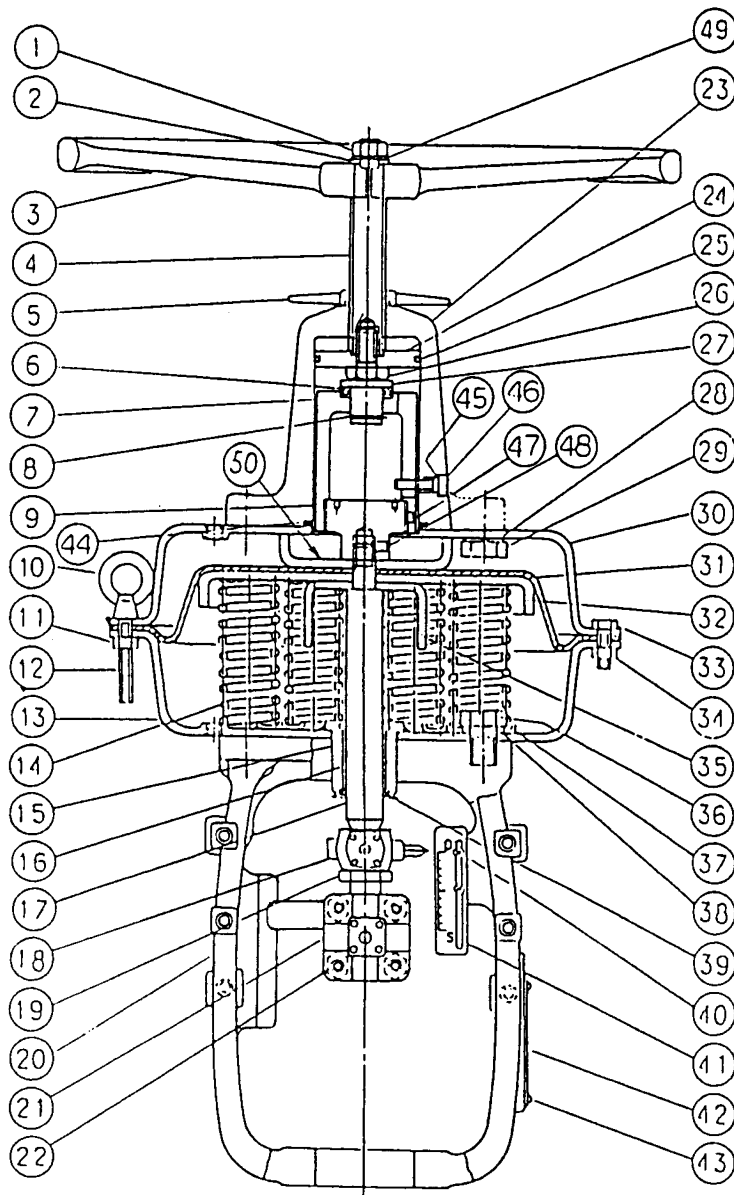

No.1	Parts Name
1	NUT
2	WASHER
3	HANDWHEEL
4	SCREW SHAFT
5	LOCK NUT
6	BEARING
7	BEARING CASE
8	COTTER
9	CONNECTOR
10	EYEBOLT
11	NUT
12	THROUGH BOLT
13	DIAPHRAGM CASE (BOTTOM)
14	COIL SPRING
15	BEARING
16	BUSHING
17	ROD
18	POINTER
19	LOCK NUT
20	YOKE
21	STEM CONNECTOR
22	STEM CONNECTOR BOLT
23	HOUSING
24	PISTON PLATE
25	O-RING
26	BOLT
27	BEARING RETAINER
28	SEAL WASHER
29	BOLT
30	DIAPHRAGM CASE (TOP)
31	DIAPHRAGM
32	DIAPHRAGM PLATE
33	BOLT
34	NUT
35	STOPPER
36	BOLT
37	SPRING PLATE
38	WASHER
39	DUST SEAL
40	TRUSS SCREW, SPEED NUT
41	SCALE
42	NAMEPLATE
43	DRIVE SCREW
44	O-RING
45	SEAL WASHER
46	KEYBOLT
47	SETSCREW
48	SETSCREW
49	SPRING WASHER
50	DIAPHRAGM RETAINER

Fig. 7-7. Model HA4 Actuator with Top Handwheel (Direct Action Type)

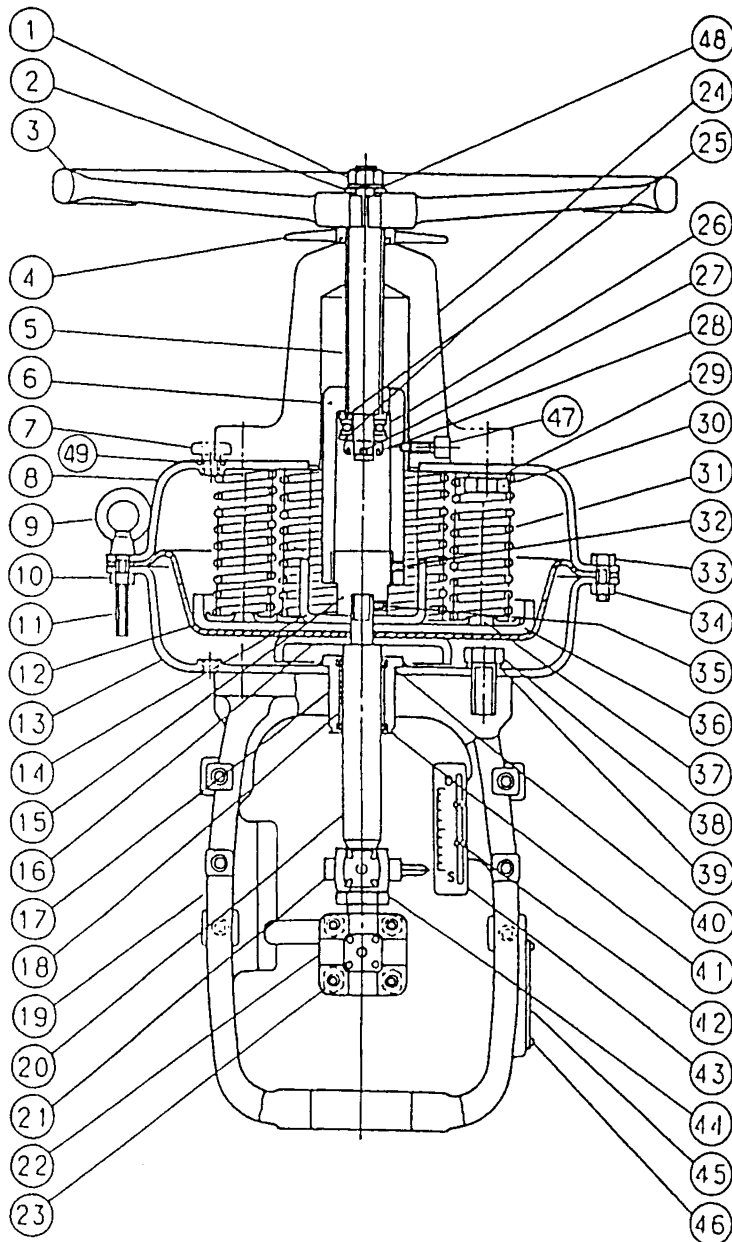

No.1	Parts Name
1	NUT
2	WASHER
3	HANDWHEEL
4	LOCK NUT
5	SCREW SHAFT
6	BEARING CASE
7	CAP
8	DIAPHRAGM CASE (TOP)
9	EYEBOLT
10	NUT
11	THROUGH BOLT
12	DIAPHRAGM
13	DIAPHRAGM CASE (BOTTOM)
14	STOPPER
15	CONNECTOR
16	DIAPHRAGM RETAINER
17	BEARING
18	BUSHING
19	YOKE
20	ROD
21	POINTER
22	STEM CONNECTOR
23	STEM CONNECTOR BOLT
24	HOUSING
25	WASHER
26	BEARING
27	COTTER PIN
28	CASTLE NUT
29	SEAL WASHER
30	BOLT
31	COIL SPRING
32	SETScrew
33	BOLT
34	NUT
35	SETScrew
36	DIAPHRAGM PLATE
37	SPRING PLATE
38	BOLT
39	SEAL WASHER
40	PACKING
41	DUST SEAL
42	TRUSS SCREW, SPEED NUT
43	SCALE
44	LOCK NUT
45	NAMEPLATE
46	DRIVE SCREW
47	KEY BOLT
48	SPRING WASHER
49	O-RING

Fig. 7-8. Model HA4 Actuator with Top Handwheel (Reverse Action Type)

7.2.2 Disassembly and Assembly of Top Handwheel

To disassemble or assemble the top handwheel, refer to Fig. 7-5 through 7-10 and proceed as described in this section. For disassembly and assembly work, keep the actuator in the vertical attitude.

(a) Direct Action Type

- (1) Disconnect the air piping.
- (2) Set the handwheel shaft in the automatic operation position (fully raise the handwheel shaft).
- (3) Remove the top diaphragm case. When doing this, loosen the pair of eyebolts uniformly and alternately, after removing all other clamping-bolts of the diaphragm case.
- (4) Sufficiently insert the handle shaft by turning it and then remove the handwheel and the lock nut. Insert the shaft further and then remove the screw shaft from the housing.
- (5) Remove the O-ring.

To assemble the top handwheel, follow the disassembly procedure in the reverse order.

(b) Reverse Action Type

- (1) Disconnect the air piping.
- (2) Set the handwheel shaft in the automatic operation position (fully lower the handwheel shaft).
- (3) Remove the handwheel and the lock nut. Insert the shaft into the housing by means of the threading until the threading sections are disengaged.
- (4) Remove the top diaphragm case. When doing this, loosen the pair of eyebolts uniformly and alternately, after removing all other clamping-bolts of the diaphragm case.
- (5) Remove the housing by loosening its clamping-screws.
- (6) Remove the setscrew and then remove the bearing case.
- (7) Remove the pin and then remove the castle nut.
- (8) Remove the bearing retainer and then remove the bearing.

To assemble the top handwheel, follow the disassembly procedure in the reverse order.

(c) Inspection After Assembly

- (1) Check that the handwheel turns smoothly for the full stroke.
- (2) For the direct action type of actuator, check by means of soapsuds that there is no air leak from the connecting sections of the housing and top diaphragm case.

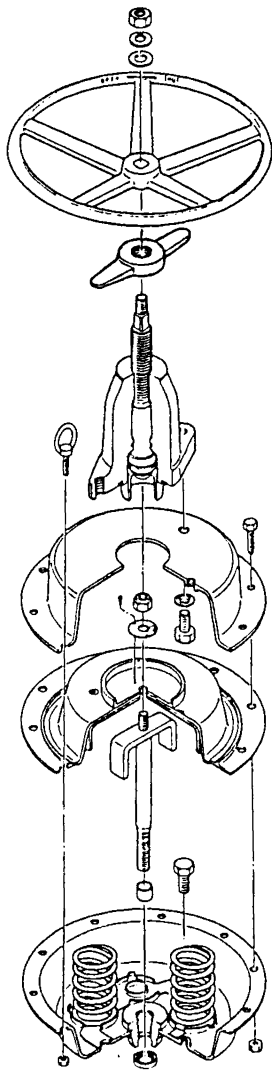

Fig. 7-9. Direct Action Type

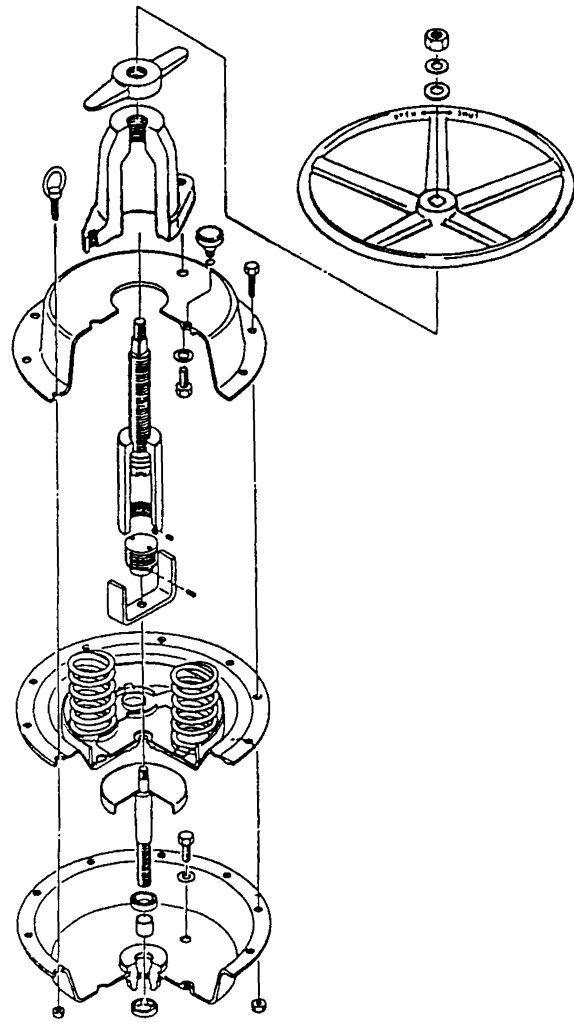

Fig. 7-10. Reverse Action Type

8. INSTRUCTIONS FOR SIDE HANDWHEEL OF ACTUATOR

As you turn the handwheel clockwise, the actuator stem moves downward regardless of whether the actuator is of the direct action type or reverse action type. The handwheel bears the "SHUT" mark to indicate that the valve is closed as the handwheel is turned clockwise and the "OPEN" mark to indicate that the valve is made open as the handwheel is turned counterclockwise.

8.1 Installation Procedure

To install the side handwheel, refer to Fig. 8-1 and proceed as follows:

- (1) Prepare a manual operation kit (a side handwheel set and its mounting accessories).
To install the handwheel, no machining or other physical processing on the actuator is necessary.
- (2) By turning the handwheel, set the pointer of the operation nut at the AUTO position.
- (3) Loosen the bolt (item number ⑥ as shown in Fig. 8-1) and widen the distance between levers.
- (4) Install the handwheel on the mounting pad at the back of the actuator, with the mounting-bolts.
- (5) Engage the holes at the end of two levers to the pointer boss and engage those of the other ends to the boss of the operation nut, and then tighten the bolt.
- (6) When the control valve is in the automatic mode of operation, set the pointer of the operation nut at the AUTO position and keep the handwheel locked.

8.2 Operating Instructions

- (1) To manually operate the actuator, remove the handwheel lock (the fork-shaped component) which locks the handwheel and turn the handwheel in the direction indicated by the corresponding arrowhead mark.
- (2) To return to the automatic operation, turn the handwheel so that the pointer of the operation nut is set at the AUTO position and then apply the handwheel lock.

Precautions: If you forcefully turn the handwheel after it has reached the mechanical stop position, the valve stem may be damaged. Do not turn the handwheel with forces larger than the below-mentioned limits.

Model HA2: 190 N {19 kgf}

Model HA3: 290 N {29 kgf}

Model HA4: 460 N {46 kgf}
(at the outermost periphery of the handwheel)

8.3 Disassembly and Assembly of Side Handwheel (Refer to Fig. 8-1)

Before starting disassembly, check that the pointer is set at the AUTO position.

- (1) Loosen the bolt ⑥ which connects the levers ② and then disengage the levers from the pointer.

- (2) Undo the mounting-bolts ① of the side handwheel unit and detach it from the actuator.
- (3) Remove the lock nut of the handwheel and then remove the handwheel.
- (4) Loosen the bolt ⑧ of the bearing holder and then remove the feed shaft ⑦.

To assemble the side handwheel, refer to Fig. 8-1 and follow the disassembly procedure in the reverse order.

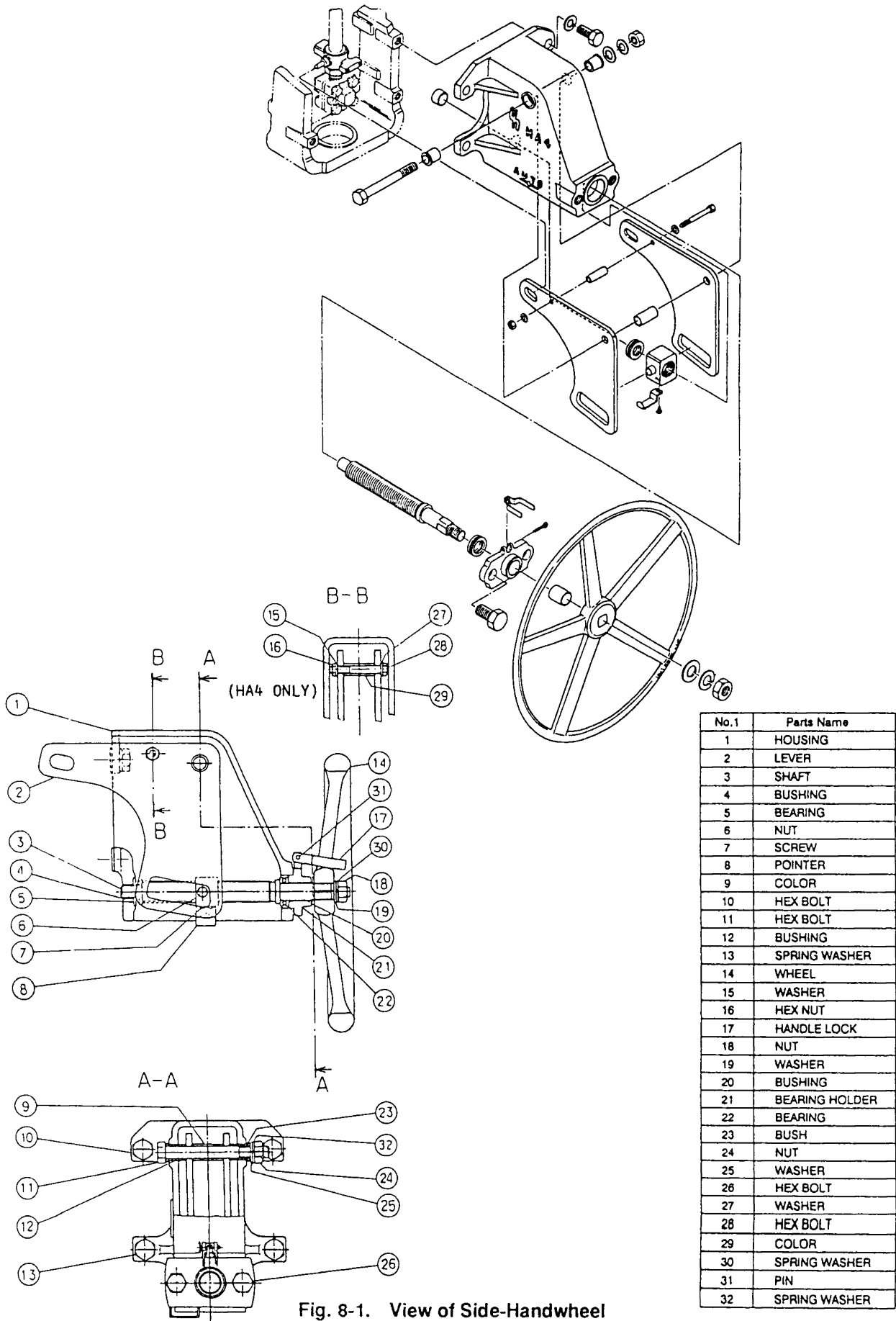

Fig. 8-1. View of Side-Handwheel

Document Number : OM2-8213-0500
Document Name : CV3000 Series Multismotor*
Multi-Spring Type Diaphragm Motors
Model : HA/HL User's Manual

Date : Feb. 1994
Jul. 1998 (Rev.3) (K)
Issued / Edited by : Yamatake Corporation

Yamatake Corporation