

Item No. / Qty	1		1		Ref. No.		
Tag No.	2SV-149				Purchaser		
Service	FLASHER FEED PRESS CONT				End user		
<Control valve>					<Remarks>		
Description					Top-Guided Single-Seat Control Valves		
Body/Port size					2-1/2 in.		2 in.
Conn. Size. / Rated CV							50
Rating / Conn. Type					JIS20K		RF
Body material					SCPH2		
Trim material					SUS316 STELLITE FACE		
Flow characteristic					EQ%		
Bonnet					PLAIN (-17 to 230 degC)		
Actuator / Handle					PSA3R		SIDE
Action					AIR TO OPEN		
Gland packing / Grease					P4519		---
Gasket					V543(PTFE)		
Air supply / Spring range					2.8kgf/cm2		0.8-2.4kgf/cm2
Seat leakage					CLASS IV		
Color: Body/Diaph./Yoke					SILVER	SILVER	SILVER
Paint					Heat Resistant		
<Accessories>							
Positioner					HTP-1D		
Structure							
Input signal					0.2-1.0 kgf/cm2		
Regulator					KZ03-2A-XX		1
Regulator2							
Limit switch							
Action							
Solenoid valve					J320G174		1
Action / Power					En: Close, De: Control		DC24V
Booster							
Air lock valve							
<Process data>							
Fluid name/Phase					BOILER FEED WATER		LIQUID
					MAX	NOR	MIN
					Unit		
Flow rate					36	m3/h	
Inlet pressure					15	kgf/cm2G	
Outlet pressure					1.8	kgf/cm2G	
Differential press.					13.2	kgf/cm2	
Shut-off press.					18		kgf/cm2
Temperature					201	degC	
Density/Gravity(Liq)					1	water=1	
Density/Gravity(G,V)							MW
Viscosity							mPa-s
Flash							%
Calculated CV					11.57		
Travel					56	%	
Inlet velocity					3.261	m/s	
Predictive SPL					70	dBA	
<Piping spec.>							
Strength Calc. Sheet							
Design							kgf/cm2G
Temp.							degC
Size					2-1/2 in.	2-1/2 in.	
Sch No.					40	40	
Thickness					5.2	5.2	
Yamatake Corporation							

* The drawing shall be handled as reference.
 * この図面は参考情報として取扱いをお願いします。

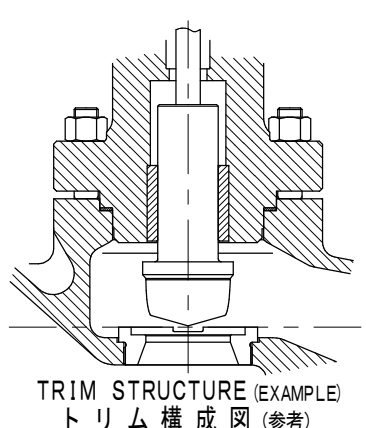
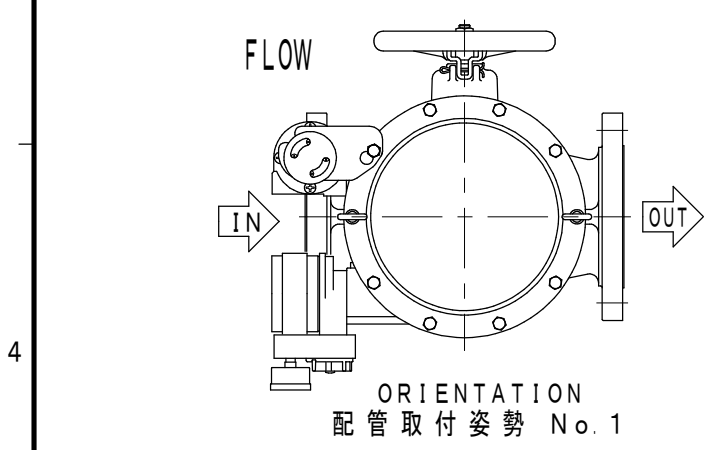
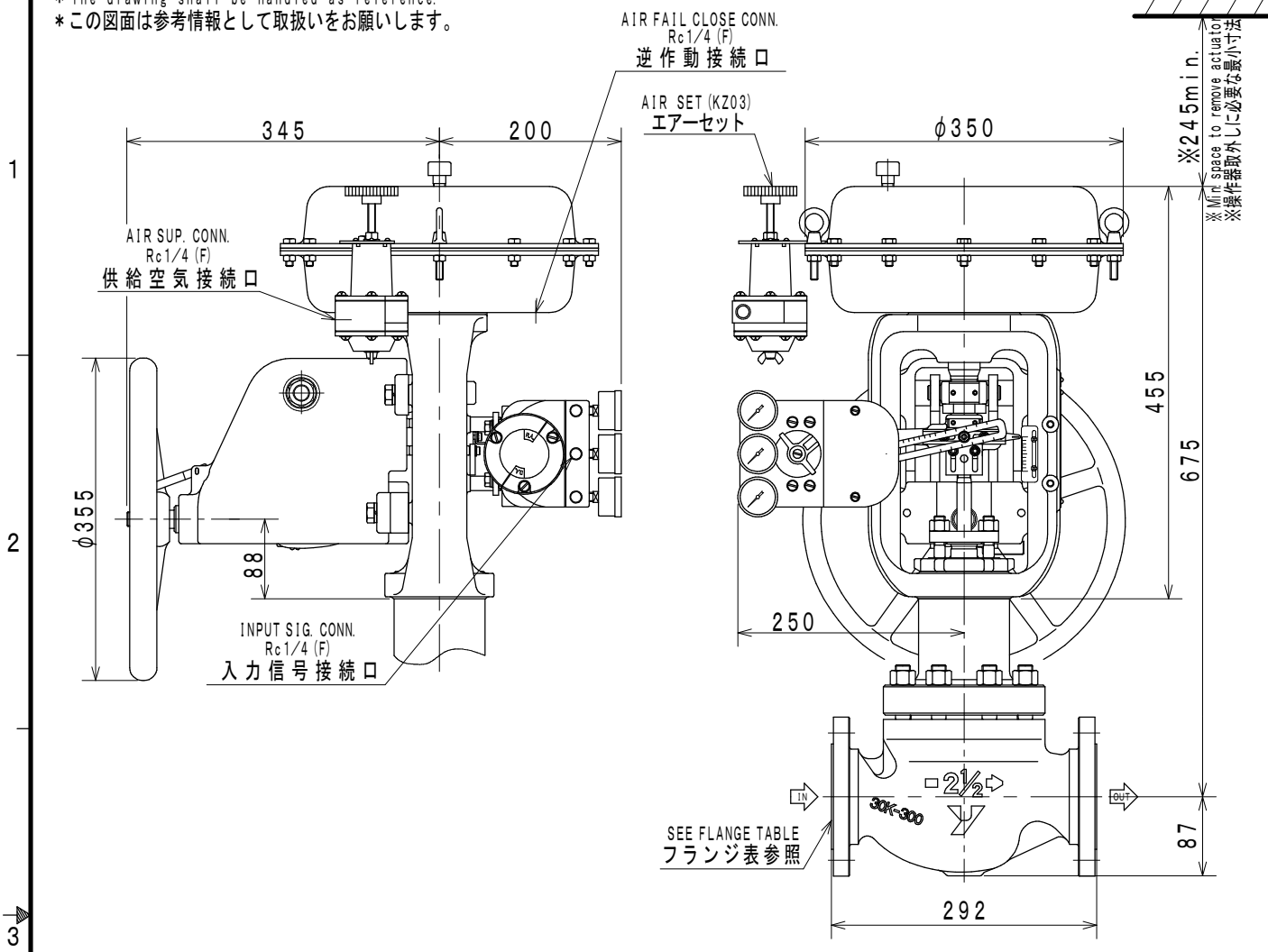

PROD. No. :
 工事番号 :
 TAG No. : 2SV-149

UNIT : mm

NOMINAL SIZE(INCH) 口径 (B)	RATING 圧力定格 (フランジ規格年度)	END CONNECTION 接続形式	BONNET TYPE 上蓋形式	ACTUATOR 操作器	VALVE ACTION 弁作動	TRAVEL トラベル	WEIGHT 概算質量(kg)
2 1/2	JIS20K (1984)	RF	PLAIN TYPE 常温形	PSA3R SHM	AIR TO OPEN	38	112
Top-Guide Single-Seated Control Valve トップガイド形単座調節弁					MODEL No. AGVM		
Yamatake Corporation					DRAWING No. AGVM-C20REE-BERS5A0		REV. 0

A B C D E

* The drawing shall be handled as reference.
 * この図面は参考情報として取扱いをお願いします。

1
2
3
4
5

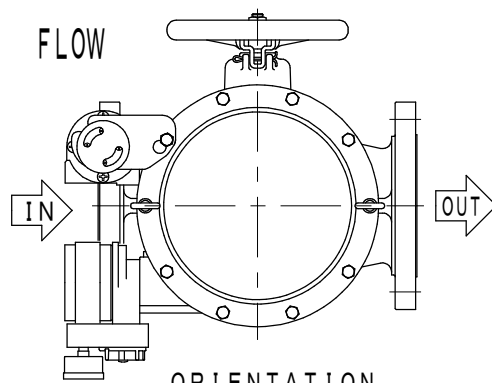
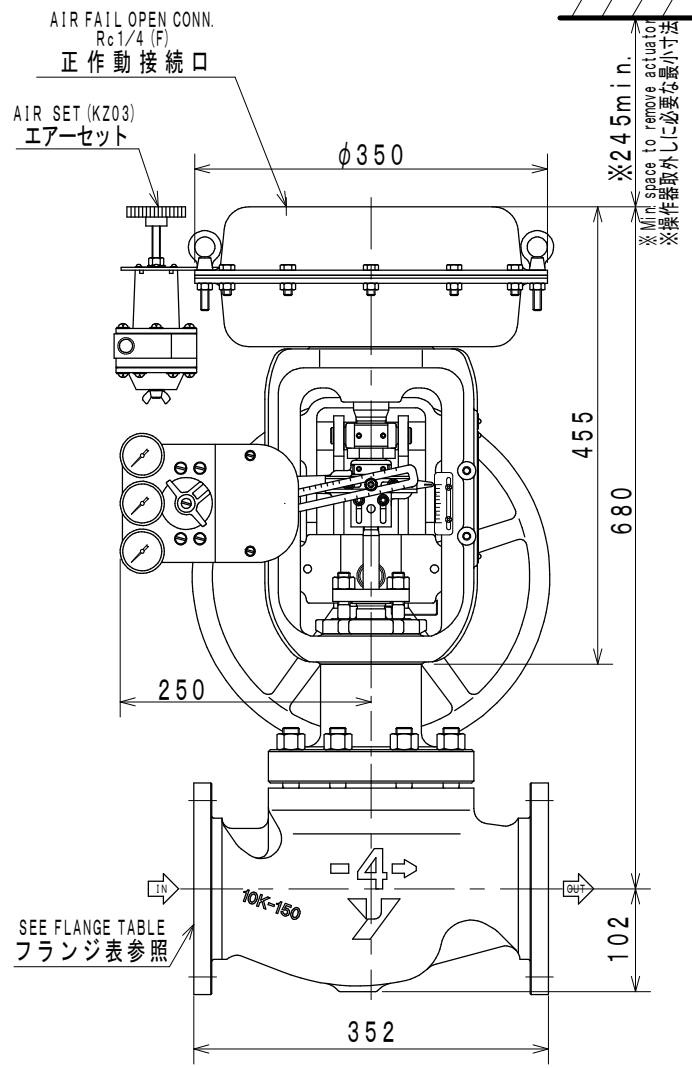
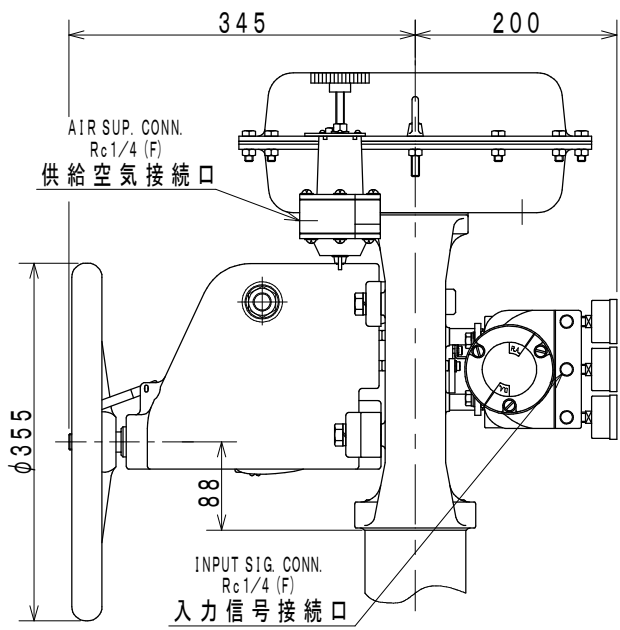

ORIENTATION
配管取付姿勢 No. 1

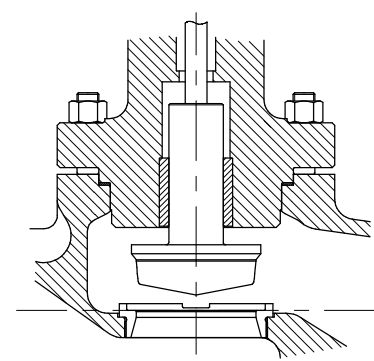

PROD. No. :
 工事番号 :
 TAG No. : 7FV-2

UNIT : mm

NOMINAL SIZE (INCH) 口径 (B)	RATING 圧力定格 (フランジ規格年度)	END CONNECTION 接続形式	BONNET TYPE 上蓋形式	ACTUATOR 操作器	VALVE ACTION 弁作動	TRAVEL トラベル	WEIGHT 概算質量 (kg)
4	JIS10K (1984)	FF	PLAIN TYPE 常温形	PSA3D SHM	AIR TO CLOSE	38	124

Top-Guide Single-Seated Control Valve トップガイド形単座調節弁					MODEL No. AGVB		
Yamatake Corporation					DRAWING No. AGVB-E10FEE-BFDS5A0		REV. 0

A B C D E