

ST3000 Series 900 Smart Transmitter

Differential Pressure Transmitters

Model STD910/STD920/STD930/STD960/STD921/STD931/STD961

OVERVIEW

The ST3000 Smart Transmitter is a microprocessor-based smart transmitter that features high performance and excellent stability. Capable of measuring gas, liquid, and vapor, and liquid levels, it transmits 4 to 20 mA DC analog and digital signals according to the measured differential pressure.

It can also execute two-way communications between the SFC (Smart Field Communicator) or HART[®] 275 communicator, and, via DE protocol, with the TDCS3000 or 3000^X and a database, thus facilitating self-diagnosis, range resetting, and automatic zero adjustment.

FEATURES

Excellent stability and high performance

- Long-term stability is proven in 500,000 installations worldwide.
- Unique characterization and composite semiconductor sensors realize excellent temperature and static pressure characteristics.

Wide measuring range (range ability)

- A wide measuring range is available from a single model. This feature is highly effective in taking measurement over a wide range and reducing the need for inventory.
- Model STD920: 0.75 to 100 kPa (rangeability: 133 to 1)

A diverse lineup

- A wide range of models is available to meet user requirements. They include draft range differential pressure, standard differential pressure, high differential pressure, standard differential pressure/high static pressure, and high differential pressure/high static pressure models.
- A wide variety of corrosion-resistant materials for wetted parts is also available.



Remote communication

- Either analog output (4 to 20 mA DC), or digital output (DE protocol) is possible.
- Two-way communication using digital output facilitates self-diagnosis, range resetting, automatic zero adjustment, and other operations.
- HART[®] protocol communication is available. (Option)

HART[®] is a registered trademark of the HART Communication Foundation.

APPLICATION**Petroleum/Petrochemical/Chemical**

For strict flow control in combination with orifice plates.

Electric power/City gas/Other utilities

For measurement applications that require high degrees of stability and accuracy.

Draft range applications such as Semiconductor Equipment Manufacturing /Clean Rooms

For applications that require highly stable, accurate measurement.

Pulp and paper

- For lines that need transmitters resistant to fluid such as chemical liquids and corrosive fluids.

Iron and steel/Nonferrous metal/Ceramics

- For highly stable, accurate measurements such as furnace pressure measurement.
- For lines that require stable measurement under strictly controlled (temperature, humidity, etc.) conditions.

Machinery/Shipbuilding

For lines that require stable measurement under strictly controlled (temperature, humidity, etc.) conditions.

FUNCTIONAL SPECIFICATIONS**Type of protection**

JIS C0920 watertight: NEMA3 and 4X

JIS F8001 class 2 watertight: IEC IP67

FM Explosionproof approval

Explosionproof for Class I (Gas, steam), Division 1, Group A, B, C, D

Dust-ignition for Class II (Inflammable dust), Division 1, Group E, F, G

Suitable for Class III (inflammable fiber), Division 1

Nonincendive for Class I, Division 2, Group A, B, C, D

FM Intrinsically safe approval

Intrinsically safe for Class I, II, III, Division 1, Group A, B, C, D, E, F, G

ATEX Flameproof approval

Certificate number: INERIS99ATEX0010 X

Ex II 2 GD EExd IIC T6 at $-20 \leq T_{amb} \leq +60^{\circ}\text{C}$

ATEX Intrinsic safety

Certificate number: KEMA03ATEX1225 X

Ex II 1 G EEx ia IIC T4 at $-20 \leq T_{amb} \leq +60^{\circ}\text{C}$

Electrical data: $U_i = 30\text{V}$

$I_i = 100\text{mA}$

$P_i = 1\text{W}$

$C_i = 3\text{nF}$

$L_i = 0.5\text{mH}$

SPECIAL CONDITIONS FOR SAFE USE (X)

Because the enclosure of the Smart Pressure Transmitter is made of aluminium, if it is mounted in an area where the use of category 1 G apparatus is required, it must be installed such, that, even in the event of rare incidents, ignition sources due to impact and friction sparks are excluded.

NEPSI Flameproof approval

Ex d II T6 (with NEPSI Dust Ignition DIP DT T13)

NEPSI Intrinsically safe approval

Ex ia IIC T5 at $-20 \leq T_{amb} \leq +60^{\circ}\text{C}$

Ex ia IIC T6 at $-20 \leq T_{amb} \leq +40^{\circ}\text{C}$

CSA Explosion-proof Approval

CSA Explosion-proof for Class I, (Division 1), Groups A, B, C and D

CSA Flameproof for Class I, Zone 1, Ex d IIC T6 at ambient temp. = -20°C to $+60^{\circ}\text{C}$

CSA Dust-ignitionproof for Class II and III, (Division 1), Groups E, F and G

EMC Conformity

89/336/EEC, 92/31/EEC, 93/68/EEC Electromagnetic Compatibility (EMC) Directive

PED Conformity (97/23/EC)

Comply with Module H (with "H1" option), or SEP (Sound Engineering Practice) for models of which maximum working pressure is 200 bar or lower.

Lowest temperature for Module H

Bolt/nut material SNB7: -10°C

SUS630: -6°C

Measuring span / Setting range / Working pressure range

Model	Measuring Span	Measuring range	Working Pressure Range
STD 910	0.1 to 2 kPa {10 to 200 mmH ₂ O}	-1 to 1 kPa {-100 to 100 mmH ₂ O}	-70 to 210 kPa {-0.7 to 2.1 kgf/cm ² } (See Figure 3, 4)
STD 920	0.75 to 100 kPa {75~10160 mmH ₂ O}	-100 to 100 kPa {-10160 to 10160 mmH ₂ O}	2.0kPa abs to 21MPa {15 mmHg abs to 210 kgf/cm ² } *Note 1, Note 2 (For vacuum pressure, see Figure 1, 2)
STD 930	35 to 700 kPa {0.35 to 7 kgf/cm ² }	-100 to 700 kPa {-1 to 7 kgf/cm ² }	2.0 kPa abs to 21 MPa {15 mmHg abs to 210 kgf/cm ² } *Note 2 (For vacuum pressure, see Figure 1, 2)
STD 960	0.25 to 14 MPa {2.5 to 140 kgf/cm ² }	-0.1 to 14 MPa {-1 to 140 kgf/cm ² }	2.0 kPa abs to 42 MPa {15mmHg abs to 420 kgf/cm ² } *Note 3 (For vacuum pressure, see Figure 1, 2)
STD 921	2.5 to 100 kPa {250~10160 mmH ₂ O}	-100 to 100 kPa {-10160 to 10160 mmH ₂ O}	2.0 kPa abs to 42 MPa {15mmHg abs to 420 kgf/cm ² } *Note 3 (For vacuum pressure, see Figure 1, 2)
STD 931	35 to 700 kPa {0.35 to 7 kgf/cm ² }	-100 to 700 kPa {-1 to 7 kgf/cm ² }	2.0 kPa abs to 42 MPa {15mmHg abs to 420 kgf/cm ² } *Note 3 (For vacuum pressure, see Figure 1, 2)
STD 961	0.25 to 14 MPa {2.5 to 140 kgf/cm ² }	-0.1 to 14 MPa {-1 to 140 kgf/cm ² }	2.0 kPa abs to 42 MPa {15mmHg abs to 420 kgf/cm ² } *Note 3 (For vacuum pressure, see Figure 1, 2)

Note) 1) With PVC wetted parts, the maximum working pressure is 1.5 MPa {15 kgf/cm²}.
 2) With SUS304 bolts and nuts, the maximum working pressure is 7 MPa {70 kgf/cm²}.
 3) With SUS304 bolts and nuts, the maximum working pressure is 23 MPa {230 kgf/cm²}.

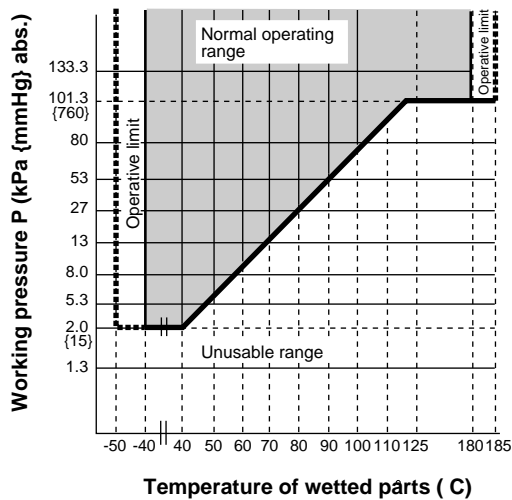

Figure 1 Working pressure and temperature of wetted parts section (for general purpose models)

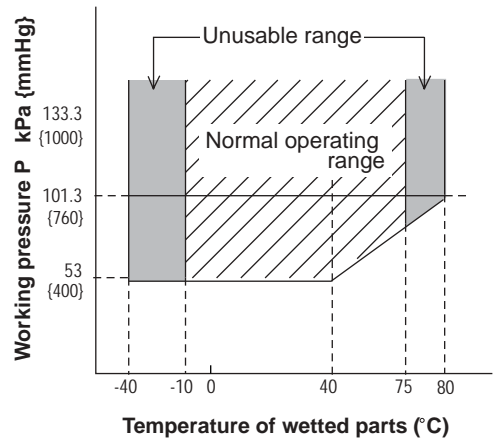

Figure 2 Working pressure and temperature of wetted parts section (for oxygen and chlorine service)

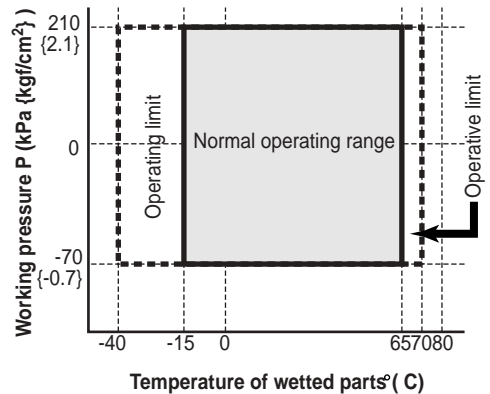

Figure 3 Working pressure and temperature of wetted parts section (for model STD910 regular type)

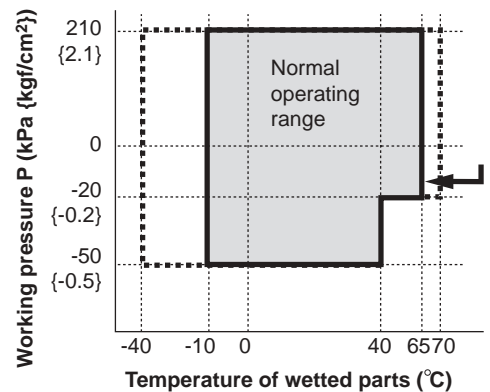

Figure 4 Working pressure and temperature of wetted parts section (for model STD910 oxygen service)

Supply voltage and load resistance

10.8 to 45V DC. A load resistance of 250 Ω or more is necessary between loops. See Figure 5.

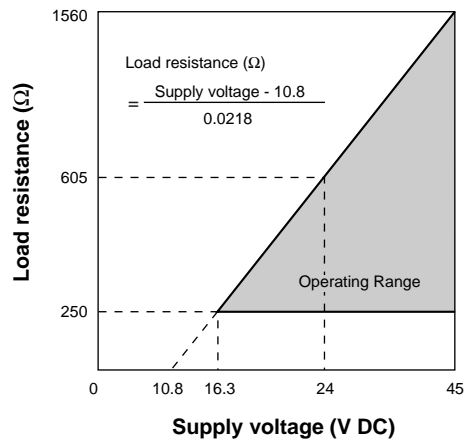

Figure 5 Supply voltage vs. load resistance characteristics

Note For communication with SFC, a load resistance of 250 Ω or more is necessary.

For ATEX Intrinsic safety model, minimum voltage of 18.0V is required.

Output

Analog output (4 to 20 mA DC) with DE protocol
 Analog output (4 to 20 mA DC) with HART protocol
 Digital output (DE protocol)

Ambient temperature limit**Normal operating range**

-40 to 85°C for general purpose models
 -15 to 65°C for general purpose model (model STD910)
 -10 to 75°C for oxygen and chlorine models
 -20 to 70°C for models with digital indicators

Operative limits

-50 to 93°C for general purpose models
 -40 to 70°C for general purpose model (model STD910)
 -40 to 80°C for oxygen and chlorine models
 -30 to 80°C for models with digital indicators

Transportation and storage conditions

-50 to 85°C for general purpose models
 -15 to 65°C for general purpose model (model STD910)

Temperature ranges of wetted parts**Normal operating range**

-40 to 110°C for general purpose models
 -15 to 65°C for general purpose model (model STD910)
 -10 to 75°C for oxygen and chlorine models

Operative limits

-50 to 115°C for general purpose models
 -40 to 70°C for general purpose model (model STD910)
 -40 to 80°C for oxygen and chlorine models

Ambient humidity limits

5 to 100% RH

Stability against supply voltage change

± 0.005% FS/V

Dead time

Approximately 0.4 sec.

Damping time

Selectable from 0 to 32 sec. in ten stages

OPTIONAL SPECIFICATIONS**Lightning protection**

Peak value of voltage surge: 200 kV

Peak value of current surge: 2000A

Built-in indicating meter

The digital LCD indicator (optional) indicates engineering units and can be set freely between -19999 and 19999 (4.5 digits). For meter calibration, specify the following items when placing your order

- Meter calibration range
- Meter calibration unit
- Linear / Square-root for meter indication.

Various kinds of data can be set using the SFC smart communicator (Ver. 7.1 or later) or HART[®]275 communicator.

Bolts and nuts materials (for fastening meter body cover)

Carbon steel (SNB7), SUS304, SUS630

Corrosion-resistant finish**Standard**

Corrosion-resistant paint (Baked acrylic paint)

Corrosion-resistant finish

Corrosion-resistant paint (Baked acrylic paint), fungus-proof finish

Corrosion-proof finish

Corrosion-proof paint (Baked epoxy paint), fungus-proof finish

Corrosion-resistant finish (silver paint)

Transmitter case is coated with silver paint in addition to the above corrosion-resistant finish.

Oil free finish

The transmitter is shipped with oil-free wetted parts.

Adapters for anticorrosion materials

These are adaptor flanges to connect 82 mm pipes made of anticorrosion materials (excluding Hastelloy C) to 54 mm general-purpose pipes.

External zero/span adjustment function

The transmitter can be easily zero/span adjusted in the field.

Burnout feature

Choice of three states at abnormal condition

Burnout of output values: None, upper limit, lower limit

Elbow

This is an adaptor for changing the electrical conduit connection port from the horizontal to the vertical direction, if required by wiring conditions in the field. One or two elbows may be used as needed.

Conformance to SI units

We deliver transmitters set to any SI units as specified.

PHYSICAL SPECIFICATIONS**Materials****Fill fluid**

Silicone oil for general purpose models
Fluorine oil for oxygen and chlorine models

Center body

SUS316

Transmitter case

Aluminum alloy

Meter body cover

Carbon steel (SF440A), galvanized
Carbon steel (SF440A), nickel plated

For Wetted parts**Adapter flange (option)**

SCS14A (Equivalent to SUS316), PVC

Center body

SUS316 (Diaphragm SUS316L)
Hastelloy C, Tantalum, SUS316L

Vents and plugs

SUS316, PVC

Gaskets

FEP, SFVC2A for STG981

Finish

Housing light beige (Munsell 4Y7.2/1.3)
Cap dark beige (Munsell 10YR4.7/0.5)

Weight

Approx. 4.4 kg (model STD920)

INSTALLATION**Electrical connection**

1/2NPT internal thread

Grounding

Resistance 100 Ω max.

Mounting

Can be installed on a 2-inch horizontal or vertical pipe
(can be directly mounted on a process pipe)

Process connection

Rc1/2, 1/2NPT internal thread and Rc1/4, 1/4NPT internal thread.

PERFORMANCE SPECIFICATIONS**Accuracy**

Shown for each item are the percentage ratio for χ (kPa), which is the greatest value of either the upper range value (URV)^{*1}, the lower range value (LRV)^{*2} or the span.

Model STD910

(Material of wetted parts: Diaphragm; SUS316L, Others; SUS316)

Accuracy	Linear output: $\pm\left(0.15 + 0.15 \times \frac{1.0}{\chi}\right) \%$ When output is 50 to 100%: same as linear output Square-root output: When output is 7.1 to 50%: linear output $\times \frac{50}{\text{square-root} \cdot \text{output}} \%$ When output is less than 7.1%: dropout
Temperature characteristics (Shift from the set range) Change of 30°C	Zero shift: $\pm\left(0.15 + 0.35 \times \frac{1.0}{\chi}\right) \%$ Combined shift: (including zero and span shifts) $\pm\left(0.2 + 0.6 \times \frac{1.0}{\chi}\right) \%$
Static pressure effect (Shift with respect to Setting range) Change of 70 kPa {0.7 kgf/cm²}	Zero shift: $\pm\left(0.03 + 0.4 \times \frac{1}{\chi}\right) \%$ Combined shift: (including zero and span shifts) $\pm\left(0.03 + 0.45 \times \frac{1}{\chi}\right) \%$

Model STD920 / 921

(Material of wetted parts: Diaphragm; SUS316L, Others; SUS316)

Accuracy (*3)	Linear output: $\pm 0.075\%$ (For $\chi \geq 50.0kPa$ {5000mmH ₂ O}) $\pm 0.1\%$ (For $50.0kPa$ {5000mmH ₂ O} > $\chi \geq 5.0kPa$ {500 mmH ₂ O}) $\pm\left(0.025 + 0.075 \times \frac{5.0}{\chi}\right) \%$ (For $\chi < 5.0kPa$ {500 mmH ₂ O}) Square-root output: When output is 50 to 100%: same as the linear output When output is 7.1 to 50%: linear output $\times \frac{50}{\text{square-root} \cdot \text{output}} \%$ When output is less than 7.1%: dropout
Temperature characteristics (Shift from the set range) (*3) Change of 55°C	Zero shift: $\pm\left(0.25 + 0.3 \times \frac{12.5}{\chi}\right) \%$ Combined shift: (including zero and span shifts) $\pm 0.8\%$ (For $\chi \geq 12.5kPa$ {1250 mmH ₂ O}) $\pm\left(0.35 + 0.45 \times \frac{12.5}{\chi}\right) \%$ (For $\chi \leq 12.5kPa$ {1250 mmH ₂ O})
Static pressure effect (Shift with respect to Setting range) (*3) Change of 7 MPa {70 kgf/cm²}	Zero shift: $\pm\left(0.03 + 0.17 \times \frac{20}{\chi}\right) \%$ Combined shift: (including zero and span shifts) $\pm 0.4\%$ (For $\chi \geq 20.0kPa$ {2000 mmH ₂ O}) $\pm\left(0.03 + 0.37 \times \frac{20}{\chi}\right) \%$ (For $\chi < 20.0kPa$ {2000 mmH ₂ O})

Note) *1: URV denotes the process value for 100% (20 mA DC) output

*2: LRV denotes the process value for 0% (4 mA DC) output.

*3: Within a range of $URV \geq 0$ and $LRV \geq 0$.

Model STD930 / 931

(Material of wetted parts: Diaphragm; SUS316L, Others; SUS316)

Accuracy (*3)	Linear output: $\pm 0.1\%$ (For $\chi \geq 140kPa$ {1.4 kgf/cm ² }) $\pm \left(0.025 + 0.075 \times \frac{140}{\chi}\right) \%$ (For $\chi < 140kPa$ {1.4 kgf/cm ² }) Square-root output: When output is 50 to 100%: same as the linear output When output is 7.1 to 50%: linear output $\times \frac{50}{\text{square-root} \cdot \text{output}} \%$ When output is less than 7.1%: dropout
Temperature characteristics (Shift from the set range) (*3) Change of 55°C	Zero shift: $\pm \left(0.25 + 0.3 \times \frac{210}{\chi}\right) \%$ Combined shift: $\pm 0.8\%$ (For $\chi \geq 210kPa$ {2.1 kgf/cm ² }) $\pm \left(0.35 + 0.45 \times \frac{210}{\chi}\right) \%$ (For $\chi < 210kPa$ {2.1 kgf/cm ² })
Static pressure effect (Shift with respect to Setting range) (*3) Change of 7 MPa {70 kgf/cm²}	Zero shift: $\pm \left(0.03 + 0.17 \times \frac{700}{\chi}\right) \%$ Combined shift: $\pm \left(0.03 + 0.37 \times \frac{700}{\chi}\right) \%$

Model STD960 / 961

(Material of wetted parts: Diaphragm; SUS316L, Others; SUS316)

Accuracy (*3)	Linear output: $\pm 0.15\%$ (For $\chi \geq 3.5MPa$ {35 kgf/cm ² }) $\pm \left(0.1 + 0.05 \times \frac{3.5}{\chi}\right) \%$ (For $\chi < 3.5MPa$ {35 kgf/cm ² }) Square-root output: When output is 50 to 100%: same as the linear output When output is 7.1 to 50%: linear output $\times \frac{50}{\text{square-root} \cdot \text{output}} \%$ When output is less than 7.1%: dropout
Temperature characteristics (Shift from the set range) Change of 55°C (*3) (Range from -5 to 55°C)	Zero shift: $\pm \left(0.25 + 0.3 \times \frac{3.5}{\chi}\right) \%$ Combined shift: $\pm 0.8\%$ (For $\chi \geq 3.5MPa$ {35 kgf/cm ² }) $\pm \left(0.35 + 0.45 \times \frac{3.5}{\chi}\right) \%$ ($\chi < 3.5MPa$ {35 kgf/cm ² })
Static pressure effect (Shift with respect to Setting range) (*3) Change of 7 MPa {70 kgf/cm²}	Zero shift: $\pm \left(0.03 + 0.17 \times \frac{7}{\chi}\right) \%$ Combined shift: $\pm 0.4\%$ (For $\chi \geq 7MPa$ {70 kgf/cm ² }) $\pm \left(0.03 + 0.37 \times \frac{7}{\chi}\right) \%$ (For $\chi < 7MPa$ {70 kgf/cm ² })

Note) *3: Within a range of URV ≥ 0 and LRV ≥ 0 .

Model STD920

(Material of wetted parts: Diaphragm; Hastelloy C, Tantalum, SUS316L Others; Hastelloy C, Tantalum, SUS316L)

<p>Accuracy (*3)</p>	<p>Linear output: $\pm 0.3\%$ (For $\chi \geq 5.0kPa$ {500mmH₂O}) $\pm\left(0.225 + 0.075 \times \frac{5.0}{\chi}\right)\%$ (For $\chi < 5.0kPa$ {500 mmH₂O})</p> <p>Square-root output: When output is 50 to 100%: same as the linear output When output is 7.1 to 50%: linear output $\times \frac{50}{\text{square-root} \cdot \text{output}}\%$ When output is less than 7.1%: dropout</p>
<p>Temperature characteristics (Shift from the set range) Change of 30°C (*3) (Range from -5 to 55°C)</p>	<p>Zero shift: $\pm\left(0.15 + 0.6 \times \frac{20.0}{\chi}\right)\%$</p> <p>Combined shift: (including zero and span shifts) $\pm\left(0.55 + 0.65 \times \frac{20.0}{\chi}\right)\%$</p>
<p>Static pressure effect (Shift with respect to Setting range) (*3) Change of 7 MPa {70 kgf/cm²}</p>	<p>Zero shift: $\pm\left(0.03 + 0.62 \times \frac{20.0}{\chi}\right)\%$</p> <p>Combined shift: (including zero and span shifts) $\pm\left(0.55 + 0.45 \times \frac{20.0}{\chi}\right)\%$ ($\chi \geq 20.0kPa$ {2000 mmH₂O}) $\pm\left(0.18 + 0.82 \times \frac{20.0}{\chi}\right)\%$ ($\chi < 20.0kPa$ {2000 mmH₂O})</p>

Model STD930

(Material of wetted parts: Diaphragm; Hastelloy C, Tantalum, SUS316L Others; Hastelloy C, Tantalum, SUS316L)

<p>Accuracy (*3)</p>	<p>Linear output: $\pm 0.3\%$ ($\chi \geq 140kPa$ {1.4 kgf/cm²}) $\pm\left(0.025 + 0.075 \times \frac{140}{\chi}\right)\%$ (For $\chi < 140kPa$ {1.4 kgf/cm²})</p> <p>Square-root output: When output is 50 to 100%: same as the linear output When output is 7.1 to 50%: linear output $\times \frac{50}{\text{square-root} \cdot \text{output}}\%$ When output is less than 7.1%: dropout</p>
<p>Temperature characteristics (Shift from the set range) Change of 30°C (*3) (Range from -5 to 55°C)</p>	<p>Zero shift: $\pm\left(0.15 + 0.6 \times \frac{210}{\chi}\right)\%$</p> <p>Combined shift: (including zero and span shifts) $\pm 1.20\%$ ($\chi \geq 210kPa$ {2.1 kgf/cm²}) $\pm\left(0.55 + 0.65 \times \frac{210}{\chi}\right)\%$ (For $\chi < 210kPa$ {2.1 kgf/cm²})</p>
<p>Static pressure effect (Shift with respect to Setting range) (*3) Change of 7 MPa {70 kgf/cm²}</p>	<p>Zero shift: $\pm\left(0.03 + 0.62 \times \frac{700}{\chi}\right)\%$</p> <p>Combined shift: (including zero and span shifts) $\pm\left(0.03 + 0.50 \times \frac{700}{\chi}\right)\%$</p>

Note) *3: Within a range of URV ≥ 0 and LRV ≥ 0 .

Model STD960

(Material of wetted parts: Diaphragm; SUS316L, Others; SUS316L)

Accuracy (*3)	<p>Linear output: $\pm 0.3\%$ (For $\chi \geq 3.5MPa$ {35 kgf/cm²})</p> <p>$\pm\left(0.25 + 0.05 \times \frac{3.5}{\chi}\right)\%$ (For $\chi < 3.5MPa$ {35 kgf/cm²})</p> <p>Square-root output: When output is 50 to 100%: same as the linear output</p> <p>When output is 7.1 to 50%: linear output $\times \frac{50}{\text{square-root} \cdot \text{output}}\%$</p> <p>When output is less than 7.1%: dropout</p>
Temperature characteristics (Shift from the set range) Change of 30°C(*3) (Range from -5 to 55°C)	<p>Zero shift: $\pm\left(0.15 + 0.6 \times \frac{3.5}{\chi}\right)\%$</p> <p>Combined shift: $\pm 1.20\%$ (For $\chi \geq 3.5MPa$ {35 kgf/cm²})</p> <p>(including zero and span shifts) $\pm\left(0.55 + 0.65 \times \frac{3.5}{\chi}\right)\%$ (For $\chi < 3.5MPa$ {35 kgf/cm²})</p>
Static pressure effect (Shift with respect to Setting range) (*3) Change of 7 MPa {70 kgf/cm²}	<p>Zero shift: $\pm\left(0.03 + 0.295 \times \frac{7}{\chi}\right)\%$</p> <p>Combined shift: $\pm\left(0.45 + 0.125 \times \frac{7}{\chi}\right)\%$ (For $\chi \geq 7MPa$ {70 kgf/cm²})</p> <p>(including zero and span shifts) $\pm\left(0.08 + 0.495 \times \frac{7}{\chi}\right)\%$ (For $\chi < 7MPa$ {70 kgf/cm²})</p>

Note) *3: Within a range of URV ≥ 0 and LRV ≥ 0 .

MODEL SELECTION

ST3000 series 900 electric differential pressure transmitter

Model STD910 (Standard type for lowest differential pressure)

Model No.: STD910 - I II III - 00000 - Option I - Option II

Basic Model No.

Measuring span	0.1 to 2.0 kPa (10 to 200 mmH ₂ O)	STD910
----------------	---	--------

Selection I				Code	Material Code		
I	Material	Meter body Cover	Adapter flange	Vent / drain plugs	Wetted parts of center body	E	
		SCS14A *1	SCS14A*1	SUS316	Diaphragm: SUS316L	E	-
II	Fill fluid	Regular type (Silicone oil)			1	✓	
		For oxygen service (Fluorine oil) *3			2	✓	
III	Process connection	Front connection	Rc1/2 with adapter flange		J	✓	
			1/2NPT internal thread with adapter flange		H	✓	
			Rc1/4 with adapter flange		M	✓	
			1/4NPT internal thread with adapter flange		N	✓	
			1/4NPT internal thread on head		P	✓	
				-			
				00000			
				-			
Options I		No options		X			
		Lightning arrester		L	✓		
		Built-in indicating smart meter (0 to 100% liner scales)		P	✓		
		Built-in indicating smart meter (engineering unit scales)		R	✓		
		SUS304 bolt and nuts material *4		W	✓		
		SUS630 bolt and nuts material *4		U	✓		
		Corrosion-resistant finish		A	✓		
		Corrosion-proof finish		B	✓		
		Corrosion-resistant finish, silver paint		D	✓		
		Oil Free finish		K	✓		
		Long vent/ drain plugs		J	✓		
		FM Explosionproof		3	✓		
		FM Intrinsically safe		4	✓		
		Combination of FM Explosionproof and Intrinsically safe		5	✓		
		ATEX Flameproof		6	✓		
		ATEX Intrinsic safety		7	✓		
		CSA Explosion-proof		8	✓		
				-			
Options II		No options		XX	✓		
		Burn-out feature (Lower limit of value at abnormal condition) *2		A4	✓		
		Burn-out feature (Upper limit of value at abnormal condition) *2		A5	✓		
		Water free finish (with Oil free finish)		A7	✓		
		NEPSI Flameproof		C1	✓		
		NEPSI Intrinsically safe		C2	✓		
		Custom calibration		C7	✓		
		Digital output *38		D5	✓		
		HART communication *5 *38		D7	✓		
		One elbow		E1	✓		
		Two elbows		E2	✓		
		External zero/ span adjustment		E5	✓		
		Mounting bracket		E9	✓		
		Side vent/ drain top		F1	✓		
		Side vent/ drain bottom		F2	✓		
		Material certificate		H2	✓		
		SI unit		U1	✓		

Note) *1 SCS14A (Equivalent SUS316) or SUS316

*2 The output current value ranges from 3.0 to 3.8 mA for the lower limit and from 20.8 to 21.8 mA for the upper limit.

*3 In case "For oxygen or chlorine (Fluorine oil) service" is used, it's recommended to select "oil free finish - code K"

*4 Notes of "Order entry": "W" or "U" must be selected.

*5 Intrinsically safe for NEPSI cannot be selected with -D7.

*38 Either one of "Digital output - code D5" or "HART communication - code D7" can be selected at a time.

ST3000 series 900 electric differential pressure transmitter
Model STD920 (Standard type for medium differential pressure)
 Model No.: STD920 - I II III - 00000 - Option I - Option II

Basic Model No.

Measuring span	0.75 to 100 kPa (75 to 10,160 mmH ₂ O)	STD920
----------------	---	--------

Selection I					Code	Material code												
I	Material	Meter body cover	Adapter flange	Vent / drain plugs	Wetted parts of center body		A	B	D	E	F	H	U	M	P	8	9	
		Carbon steel	SCS14A*1	SUS316	Diaphragm: SUS316L Others: SUS316	A												
		Carbon steel	SCS14A*1	SUS316	Diaphragm: Hastelloy C Others: Hastelloy C	B												
		Carbon steel	SCS14A*1	SUS316	Diaphragm: Tantalum Others: Tantalum	D												
		SCS14A*1	SCS14A*1	SUS316	Diaphragm:SUS316L Others: SUS316	E												
		SCS14A*1	SCS14A*1	SUS316	Diaphragm: Hastelloy C Others: Hastelloy C	F												
		SCS14A*1	SCS14A*1	SUS316	Diaphragm: Tantalum Others: Tantalum	H												
		SCS14A*1	SCS14A*1	SUS316	Diaphragm:SUS316L Others: SUS316L	U												
		PVC	PVC	PVC	Diaphragm: Hastelloy C Others: Hastelloy C *8	M												
		PVC	PVC	PVC	Diaphragm: Tantalum Others: Tantalum *8	P												
		Carbon steel Ni plating	SCS14A*1	SUS316	Diaphragm: Hastelloy C Others: Hastelloy C	8												
		Carbon steel Ni plating	SCS14A*1	SUS316	Diaphragm:SUS316L Others: SUS316	9												
II	Fill fluid	Regular type (Silicone oil)			1	✓	✓	✓	✓	✓	✓	✓	✓	✓	✓	✓	✓	
		For oxygen service (Fluorine oil) *3			2				✓	✓	✓	✓	✓	✓	✓			
		For chlorine service (Fluorine oil) *3			5						✓				✓			
III	Process connection	Front connection	Rc1/2 with adapter flange		J	✓	✓		✓	✓						✓	✓	
			1/2NPT internal thread with adapter flange		H	✓	✓		✓	✓							✓	✓
			Rc1/4 with adapter flange		M	✓	✓		✓	✓							✓	✓
			1/4NPT internal thread with adapter flange		N	✓	✓		✓	✓							✓	✓
			1/4NPT internal thread on head		P	✓	✓		✓	✓							✓	✓
	Top or bottom connection	Rc1/2 with adapter flange *7		Q			✓				✓	✓	✓	✓				
		1/2NPT internal thread with adapter flange *7		R			✓				✓	✓	✓	✓				
		Rc1/4 with adapter flange *7		S			✓				✓	✓						
		1/4NPT internal thread with adapter flange *7		T			✓				✓	✓						
		1/4NPT internal thread on head *7		U			✓				✓	✓						

(Continued)

(Continued from previous page)

Model No.: STD920 - I II III - 00000 - **Option I - Option II**

	Code	Material Code															
		A	B	D	E	F	H	U	M	P	8	9					
Options I	No options	X	✓	✓	✓	✓	✓	✓	✓	✓	✓	✓	✓	✓	✓	✓	
	Lightning arrester	L	✓	✓	✓	✓	✓	✓	✓	✓	✓	✓	✓	✓	✓	✓	✓
	Built-in indicating smart meter (0 to 100% liner scales)	P	✓	✓	✓	✓	✓	✓	✓	✓	✓	✓	✓	✓	✓	✓	✓
	Built-in indicating smart meter (engineering unit scales)	R	✓	✓	✓	✓	✓	✓	✓	✓	✓	✓	✓	✓	✓	✓	✓
	SUS304 bolt and nuts material	W	✓	✓	✓	✓	✓	✓	✓	✓	✓	✓	✓	✓	✓	✓	✓
	SUS630 bolt and nuts material	U	✓	✓	✓	✓	✓	✓	✓						✓	✓	✓
	Corrosion-resistant finish	A	✓	✓	✓	✓	✓	✓	✓	✓	✓	✓	✓	✓	✓	✓	✓
	Corrosion-proof finish	B	✓	✓	✓	✓	✓	✓	✓	✓	✓	✓	✓	✓	✓	✓	✓
	Corrosion-resistant finish, silver paint	D	✓	✓	✓	✓	✓	✓	✓	✓	✓	✓	✓	✓	✓	✓	✓
	Oil free finish	K				✓	✓	✓	✓	✓	✓	✓					
	Long vent/ drain plugs	J	✓	✓	✓	✓	✓	✓	✓						✓	✓	✓
	FM Explosionproof	3	✓	✓	✓	✓	✓	✓	✓	✓	✓	✓	✓	✓	✓	✓	✓
	FM Intrinsically safe	4	✓	✓	✓	✓	✓	✓	✓	✓	✓	✓	✓	✓	✓	✓	✓
	Combination of FM Explosionproof and Intrinsically safe	5	✓	✓	✓	✓	✓	✓	✓	✓	✓	✓	✓	✓	✓	✓	✓
	ATEX Flameproof	6	✓	✓	✓	✓	✓	✓	✓	✓	✓	✓	✓	✓	✓	✓	✓
	ATEX Intrinsic safety	7	✓	✓	✓	✓	✓	✓	✓	✓	✓	✓	✓	✓	✓	✓	✓
CSA Explosion-proof	8	✓	✓	✓	✓	✓	✓	✓	✓	✓	✓	✓	✓	✓	✓	✓	
	-																
Options II	No option	XX	✓	✓	✓	✓	✓	✓	✓	✓	✓	✓	✓	✓	✓	✓	
	Adapter flange for corrosion -resistant application *6	A1			✓			✓	✓			✓					
	Burn-out feature (Lower limit of value at abnormal condition) *2	A4	✓	✓	✓	✓	✓	✓	✓	✓	✓	✓	✓	✓	✓	✓	
	Burn-out feature (Upper limit of value at abnormal condition) *2	A5	✓	✓	✓	✓	✓	✓	✓	✓	✓	✓	✓	✓	✓	✓	
	Water free finish (with Oil free finish)	A7				✓	✓	✓	✓	✓	✓	✓	✓				
	NEPSI Flameproof	C1	✓	✓	✓	✓	✓	✓	✓	✓	✓	✓	✓	✓	✓	✓	
	NEPSI Intrinsically safe	C2	✓	✓	✓	✓	✓	✓	✓	✓	✓	✓	✓	✓	✓	✓	
	Custom calibration	C7	✓	✓	✓	✓	✓	✓	✓	✓	✓	✓	✓	✓	✓	✓	
	Digital output *38	D5	✓	✓	✓	✓	✓	✓	✓	✓	✓	✓	✓	✓	✓	✓	
	HART communication *5 *38	D7	✓	✓	✓	✓	✓	✓	✓	✓	✓	✓	✓	✓	✓	✓	
	One elbow	E1	✓	✓	✓	✓	✓	✓	✓	✓	✓	✓	✓	✓	✓	✓	
	Two elbows	E2	✓	✓	✓	✓	✓	✓	✓	✓	✓	✓	✓	✓	✓	✓	
	External zero/ span adjustment	E5	✓	✓	✓	✓	✓	✓	✓	✓	✓	✓	✓	✓	✓	✓	
	Mounting bracket	E9	✓	✓	✓	✓	✓	✓	✓	✓	✓	✓	✓	✓	✓	✓	
	Side vent/ drain top	F1	✓	✓		✓	✓								✓	✓	
	Side vent/ drain bottom	F2	✓	✓		✓	✓								✓	✓	
	PED (97/23/EC) conformity *34 *35	H1	✓	✓	✓	✓	✓	✓	✓						✓	✓	
	Material certificate	H2	✓	✓	✓	✓	✓	✓	✓	✓	✓	✓	✓	✓	✓	✓	
	Max. working pressure 20 MPa *35 *37	H3	✓	✓	✓	✓	✓	✓	✓	✓					✓	✓	
	SI unit	U1	✓	✓	✓	✓	✓	✓	✓	✓	✓	✓	✓	✓	✓	✓	

Note) *1 SCS14A (Equivalent SUS316) or SUSF316
 *2 The output current value ranges from 3.0 to 3.8 mA for the lower limit and from 20.8 to 21.8 mA for the upper limit.
 *3 In case "For oxygen or chlorine (Fluorine oil) service" is used, "oil free finish - code K" must be selected.
 *5 Intrinsically safe for NEPSI approval cannot be selected with -D7.
 *6 In case Manifold valve is used and in case code D, H, U or P is used, please select code A1 of Option II
 *7 Applicable for wetted parts of center body material;Tantalum,SUS316L
 *8 SUS304 bolts and nuts material (-W) must be selected when PVC meterbody cover is selected (-M or -P)
 *11 When SUS304 bolt/nut is selected, max working pressure rating is 7 MPa (70 kgf/cm²).
 *34 "PED conformity" is not applicable for the combination with FM, CSA or NEPSI approvals.
 *35 Not applicable for the combination with "SUS304 bolts / nuts"
 *37 Not applicable for the combination with "PED conformity"
 *38 Either one of "Digital output - code D5" or "HART communication -code D7" can be selected at a time.

ST3000 series 900 electric differential pressure transmitter
Model STD930 (Standard type for high differential pressure)
 Model No.: STD930 - I II III - 00000 - Option I - Option II

Basic Model No.

Measuring span	35 to 700 kPa (0.35 to 7 kgf/cm ²)	STD930
----------------	--	--------

Selection I					Code	Material code													
I	Material	Meter body cover	Adapter flange	Vent/ drain plugs	Wetted parts of center body		A	B	D	E	F	H	U	M	P	8	9		
		Carbon steel	SCS14A*1	SUS316	Diaphragm: SUS316L Others: SUS316	A													
		Carbon steel	SCS14A*1	SUS316	Diaphragm: Hastelloy C Others: Hastelloy C	B													
		Carbon steel	SCS14A*1	SUS316	Diaphragm: Tantalum Others: Tantalum	D													
		SCS14A*1	SCS14A*1	SUS316	Diaphragm:SUS316L Others: SUS316	E													
		SCS14A*1	SCS14A*1	SUS316	Diaphragm: Hastelloy C Others: Hastelloy C	F													
		SCS14A*1	SCS14A*1	SUS316	Diaphragm: Tantalum Others: Tantalum	H													
		SCS14A*1	SCS14A*1	SUS316	Diaphragm:SUS316L Others: SUS316L	U													
		PVC	PVC	PVC	Diaphragm: Hastelloy C Others: Hastelloy C *6	M													
		PVC	PVC	PVC	Diaphragm: Tantalum Others: Tantalum *6	P													
		Carbon steel Ni plating	SCS14A*1	SUS316	Diaphragm: Hastelloy C Others: Hastelloy C	8													
		Carbon steel Ni plating	SCS14A*1	SUS316	Diaphragm:SUS316L Others: SUS316	9													
II	Fill fluid	Regular type (Silicone oil)				1	✓	✓	✓	✓	✓	✓	✓	✓	✓	✓	✓	✓	
		For oxygen service (Fluorine oil) *8				2				✓	✓	✓	✓	✓	✓			-	
		For chlorine service (Fluorine oil) *8				5						✓			✓				
III	Process connection	Front connection	Rc1/2 with adapter flange			J	✓	✓		✓	✓						✓	✓	
			1/2NPT internal thread with adapter flange			H	✓	✓		✓	✓							✓	✓
			Rc1/4 with adapter flange			M	✓	✓		✓	✓							✓	✓
			1/4NPT internal thread with adapter flange			N	✓	✓		✓	✓							✓	✓
			1/4NPT internal thread on head			P	✓	✓		✓	✓							✓	✓
	Top or bottom connection		Rc1/2 with adapter flange *7			Q			✓			✓	✓	✓	✓				
			1/2NPT internal thread with adapter flange *7			R			✓			✓	✓	✓	✓				
			Rc1/4 with adapter flange *7			S			✓			✓	✓						
			1/4NPT internal thread with adapter flange *7			T			✓			✓	✓						
			1/4NPT internal thread on head *7			U			✓			✓	✓						

(Continued)

(Continued from previous page)

Model No.: STD930 - I II III - 00000 - **Option I - Option II**

	Code	Material Code														
		A	B	D	E	F	H	U	M	P	8	9				
Options I	No options	X	✓	✓	✓	✓	✓	✓	✓	✓	✓	✓	✓	✓	✓	✓
	Lightning arrester	L	✓	✓	✓	✓	✓	✓	✓	✓	✓	✓	✓	✓	✓	✓
	Built-in indicating smart meter (0 to 100% liner scales)	P	✓	✓	✓	✓	✓	✓	✓	✓	✓	✓	✓	✓	✓	✓
	Built-in indicating smart meter (engineering unit scales)	R	✓	✓	✓	✓	✓	✓	✓	✓	✓	✓	✓	✓	✓	✓
	SUS304 Bolt and nuts material	W	✓	✓	✓	✓	✓	✓	✓	✓	✓	✓	✓	✓	✓	✓
	SUS630 Bolt and nuts material	U	✓	✓	✓	✓	✓	✓	✓					✓	✓	✓
	Corrosion-resistant finish	A	✓	✓	✓	✓	✓	✓	✓	✓	✓	✓	✓	✓	✓	✓
	Corrosion-proof finish	B	✓	✓	✓	✓	✓	✓	✓	✓	✓	✓	✓	✓	✓	✓
	Corrosion-resistant finish, silver paint	D	✓	✓	✓	✓	✓	✓	✓	✓	✓	✓	✓	✓	✓	✓
	Oil free finish	K				✓	✓	✓	✓	✓	✓					
	Long vent/ drain plugs	J	✓	✓	✓	✓	✓	✓	✓					✓	✓	✓
	FM Explosionproof	3	✓	✓	✓	✓	✓	✓	✓	✓	✓	✓	✓	✓	✓	✓
	FM Intrinsically safe	4	✓	✓	✓	✓	✓	✓	✓	✓	✓	✓	✓	✓	✓	✓
	Combination of FM Explosionproof and Intrinsically safe	5	✓	✓	✓	✓	✓	✓	✓	✓	✓	✓	✓	✓	✓	✓
	ATEX Flameproof	6	✓	✓	✓	✓	✓	✓	✓	✓	✓	✓	✓	✓	✓	✓
	ATEX Intrinsic safety	7	✓	✓	✓	✓	✓	✓	✓	✓	✓	✓	✓	✓	✓	✓
	CSA Explosion-proof	8	✓	✓	✓	✓	✓	✓	✓	✓	✓	✓	✓	✓	✓	✓
	-															
Options II	No option	XX	✓	✓	✓	✓	✓	✓	✓	✓	✓	✓	✓	✓	✓	
	Adapter flange for corrosion -resistant application *6	A1			✓			✓	✓			✓				
	Burn-out feature (Lower limit of value at abnormal condition) *2	A4	✓	✓	✓	✓	✓	✓	✓	✓	✓	✓	✓	✓	✓	
	Burn-out feature (Upper limit of value at abnormal condition) *2	A5	✓	✓	✓	✓	✓	✓	✓	✓	✓	✓	✓	✓	✓	
	Water free finish (with oil free finish)	A7				✓	✓	✓	✓	✓	✓	✓				
	NEPSI Flameproof	C1	✓	✓	✓	✓	✓	✓	✓	✓	✓	✓	✓	✓	✓	
	NEPSI Intrinsically safe	C2	✓	✓	✓	✓	✓	✓	✓	✓	✓	✓	✓	✓	✓	
	Custom calibration	C7	✓	✓	✓	✓	✓	✓	✓	✓	✓	✓	✓	✓	✓	
	Digital output *38	D5	✓	✓	✓	✓	✓	✓	✓	✓	✓	✓	✓	✓	✓	
	HART communication *5 *38	D7	✓	✓	✓	✓	✓	✓	✓	✓	✓	✓	✓	✓	✓	
	One elbow	E1	✓	✓	✓	✓	✓	✓	✓	✓	✓	✓	✓	✓	✓	
	Two elbows	E2	✓	✓	✓	✓	✓	✓	✓	✓	✓	✓	✓	✓	✓	
	External zero/ span adjustment	E5	✓	✓	✓	✓	✓	✓	✓	✓	✓	✓	✓	✓	✓	
	Mounting bracket	E9	✓	✓	✓	✓	✓	✓	✓	✓	✓	✓	✓	✓	✓	
	Side vent/ drain top	F1	✓	✓		✓	✓							✓	✓	
	Side vent/ drain bottom	F2	✓	✓		✓	✓							✓	✓	
	PED (97/23/EC) conformity *34 *35	H1	✓	✓	✓	✓	✓	✓	✓					✓	✓	
	Material certificate	H2	✓	✓	✓	✓	✓	✓	✓	✓	✓	✓	✓	✓	✓	
	Max. working pressure 20 MPa *35 *37	H3	✓	✓	✓	✓	✓	✓	✓					✓	✓	
	SI unit	U1	✓	✓	✓	✓	✓	✓	✓	✓	✓	✓	✓	✓	✓	

Note) *1 SCS14A (Equivalent SUS316) or SUSF316
 *2 The output current value ranges from 3.0 to 3.8 mA for the lower limit and from 20.8 to 21.8 mA for the upper limit.
 *3 In case "For oxygen or chlorine (Fluorine oil) service" is used, "oil free finish - code K" must be selected.
 *5 Intrinsically safe for NEPSI cannot be selected with -D7
 *6 In case Manifold valve is used and in case code D, H, U or P is used, please select code A1 of Option II.
 *7 Applicable for wetted parts of center body material;Tantalum,SUS316L
 *8 SUS304 bolts and nuts material (-W) must be selected when PVC meterbody cover is selected (-M or -P)
 *11 When SUS304 bolt/nut is selected, max working pressure rating is 7 MPa (70 kgf/cm²).
 *34 "PED conformity" is not applicable for the combination with FM, CSA or NEPSI approvals.
 *35 Not applicable for the combination with "SUS304 bolts / nuts"
 *37 Not applicable for the combination with "PED conformity"
 *38 Either one of "Digital output - code D5" or "HART communication -code D7" can be selected at a time.

ST3000 series 900 electric differential pressure transmitter

Model STD960 (Standard type for super-high differential pressure

Model No.: STD960 - I II III - 00000 - Option I - Option II

Basic Model No.

Measuring span	0.25 to 14 MPa (2.5 to 140 kgf/cm ²)	STD960
----------------	--	--------

Selection I						Code	Material code								
I	Material	Meter body cover	Adapter flange	Vent/drain plugs	Wetted parts of center Body		A	B	D	E	F	H	U	8	9
		Carbon steel	SCS14A*1	SUS316	Diaphragm: SUS316L Others: SUS316	A									
		Carbon steel	SCS14A*1	SUS316	Diaphragm: Hastelloy C Others: Hastelloy C	B									
		Carbon steel	SCS14A*1	SUS316	Diaphragm: Tantalum Others: Tantalum	D									
		SCS14A*1	SCS14A*1	SUS316	Diaphragm:SUS316L Others: SUS316	E									
		SCS14A*1	SCS14A*1	SUS316	Diaphragm: Hastelloy C Others: Hastelloy C	F									
		SCS14A*1	SCS14A*1	SUS316	Diaphragm: Tantalum Others: Tantalum	H									
		SCS14A*1	SCS14A*1	SUS316	Diaphragm:SUS316L Others: SUS316L	U									
		Carbon steel Ni plating	SCS14A*1	SUS316	Diaphragm: Hastelloy C Others: Hastelloy C	8									
		Carbon steel Ni plating	SCS14A*1	SUS316	Diaphragm:SUS316L Others: SUS316L	9									
II	Fill fluid	Regular type (Silicone oil)				1	✓	✓	✓	✓	✓	✓	✓	✓	✓
		For oxygen service (Fluorine oil) *3				2				✓	✓	✓	✓		
		For chlorine service (Fluorine oil) *3				5						✓			
III	Process Connection	Front Connection	Rc1/2 with adapter flange			J	✓			✓					✓
			1/2NPT internal thread with adapter flange			H	✓			✓					✓
			Rc1/4 with adapter flange			M	✓			✓					✓
			1/4NPT internal thread with adapter flange			N	✓			✓					✓
			1/4NPT internal thread on head			P	✓			✓					✓
	Bottom connection	Rc1/2 with adapter flange *9			Q		✓	✓		✓	✓	✓	✓		
		1/2NPT internal thread with adapter flange *9			R		✓	✓		✓	✓	✓	✓		
		Rc1/4 with adapter flange *9			S		✓	✓		✓	✓	✓	✓		
		1/4NPT internal thread with adapter flange *9			T		✓	✓		✓	✓	✓	✓		
		1/4NPT internal thread on head *9			U		✓	✓		✓	✓	✓	✓		

(Continued)

(Continued from previous page)

Model No.: STD960 - I II III - 00000 - **Option I - Option II**

	Code	Material Code											
		A	B	D	E	F	H	U	8	9			
Options I	No options	X	✓	✓	✓	✓	✓	✓	✓	✓	✓	✓	✓
	Lightning arrester	L	✓	✓	✓	✓	✓	✓	✓	✓	✓	✓	✓
	Built-in indicating smart meter (0 to 100% liner scales)	P	✓	✓	✓	✓	✓	✓	✓	✓	✓	✓	✓
	Built-in indicating smart meter (engineering unit scales)	R	✓	✓	✓	✓	✓	✓	✓	✓	✓	✓	✓
	SUS304 bolt and nuts material	W	✓	✓	✓	✓	✓	✓	✓	✓	✓	✓	✓
	SUS630 bolt and nuts material	U	✓	✓	✓	✓	✓	✓	✓	✓	✓	✓	✓
	Corrosion-resistant finish	A	✓	✓	✓	✓	✓	✓	✓	✓	✓	✓	✓
	Corrosion-proof finish	B	✓	✓	✓	✓	✓	✓	✓	✓	✓	✓	✓
	Corrosion-resistant finish, silver paint	D	✓	✓	✓	✓	✓	✓	✓	✓	✓	✓	✓
	Oil free finish	K				✓	✓	✓	✓				
	Long vent/ drain plugs	J	✓	✓	✓	✓	✓	✓	✓	✓	✓	✓	✓
	FM Explosionproof	3	✓	✓	✓	✓	✓	✓	✓	✓	✓	✓	✓
	FM Intrinsically safe	4	✓	✓	✓	✓	✓	✓	✓	✓	✓	✓	✓
	Combination of FM Explosionproof and Intrinsically safe	5	✓	✓	✓	✓	✓	✓	✓	✓	✓	✓	✓
	ATEX Flameproof	6	✓	✓	✓	✓	✓	✓	✓	✓	✓	✓	✓
	ATEX Intrinsic safety	7	✓	✓	✓	✓	✓	✓	✓	✓	✓	✓	✓
CSA Explosion-proof	8	✓	✓	✓	✓	✓	✓	✓	✓	✓	✓	✓	
	-												
Options II	No option	XX	✓	✓	✓	✓	✓	✓	✓	✓	✓	✓	✓
	Adapter flange for corrosion -resistant application *6	A1		✓	✓		✓	✓	✓	✓	✓	✓	
	Burn-out feature (Lower limit of value at abnormal condition) *2	A4	✓	✓	✓	✓	✓	✓	✓	✓	✓	✓	✓
	Burn-out feature (Upper limit of value at abnormal condition) *2	A5	✓	✓	✓	✓	✓	✓	✓	✓	✓	✓	✓
	Water free finish (with oil free finish)	A7				✓	✓	✓	✓				
	NEPSI Flameproof	C1	✓	✓	✓	✓	✓	✓	✓	✓	✓	✓	✓
	NEPSI Intrinsically safe	C2	✓	✓	✓	✓	✓	✓	✓	✓	✓	✓	✓
	Custom calibration	C7	✓	✓	✓	✓	✓	✓	✓	✓	✓	✓	✓
	Digital output *38	D5	✓	✓	✓	✓	✓	✓	✓	✓	✓	✓	✓
	HART communication *5 *38	D7	✓	✓	✓	✓	✓	✓	✓	✓	✓	✓	✓
	One elbow	E1	✓	✓	✓	✓	✓	✓	✓	✓	✓	✓	✓
	Two elbows	E2	✓	✓	✓	✓	✓	✓	✓	✓	✓	✓	✓
	External zero/span adjustment	E5	✓	✓	✓	✓	✓	✓	✓	✓	✓	✓	✓
	Mounting bracket	E9	✓	✓	✓	✓	✓	✓	✓	✓	✓	✓	✓
	Side vent/ drain top	F1	✓			✓							✓
	Side vent/ drain bottom	F2	✓			✓							✓
	PED (97/23/EC) conformity *34 *35	H1	✓	✓	✓	✓	✓	✓	✓	✓	✓	✓	✓
	Material certificate	H2	✓	✓	✓	✓	✓	✓	✓	✓	✓	✓	✓
	Max. working pressure 20 MPa *35 *37	H3	✓	✓	✓	✓	✓	✓	✓	✓	✓	✓	✓
	SI unit	U1	✓	✓	✓	✓	✓	✓	✓	✓	✓	✓	✓

Note) *1 SCS14A (Equivalent SUS316) or SUSF316
 *2 The output current value ranges from 3.0 to 3.8 mA for the lower limit and from 20.8 to 21.8 mA for the upper limit.
 *3 In case "For oxygen or chlorine (Fluorine oil) service" is used, it's recommended to select "oil free finish - code K"
 *5 Intrinsically safe for NEPSI cannot be selected with -D7.
 *6 In case Manifold valve is used and in case code B, D, F, H or 8 is used, please select code A1 of Option II
 *9 Applicable for wetted parts of center body material; Tantalum, Hastelloy C
 *11 When SUS304 bolt/nut is selected, max working pressure rating is 7 MPa (70 kgf/cm²).
 *34 "PED conformity" is not applicable for the combination with FM, CSA or NEPSI approvals.
 *35 Not applicable for the combination with "SUS304 bolts / nuts"
 *37 Not applicable for the combination with "PED conformity"
 *38 Either one of "Digital output - code D5" or "HART communication -code D7" can be selected at a time.

ST3000 series 900 electric differential pressure transmitter

Model STD921 (High static pressure type for medium differential pressure)

Model STD931 (High static pressure type for high differential pressure)

Model No.: STD921 - I II III - 00000 - Option I - Option II

Model No.: STD931 - I II III - 00000 - Option I - Option II

Basic Model No.

Measuring span	2.5 to 100 kPa (250 to 10,160 mmH ₂ O)	STD921
	35 to 700 kPa (0.35 to 7 kgf/cm ²)	STD931

Selection I			Code	Material Code			
I	Material	Meter body cover	Vent/ drain plugs	Wetted parts of center body	A	E	9
		Carbon steel	SUS316	Diaphragm:SUS316L Others: SUS316	A		
		SCS14A*1	SUS316	Diaphragm:SUS316L Others: SUS316	E		
		Carbon steel Ni plating	SUS316	Diaphragm:SUS316L Others: SUS316	9		
II	Fill fluid	Regular type (Silicone oil)		1	✓	✓	✓
		For oxygen service (Fluorine oil) *3		2		✓	
III	Process connection	Top or bottom connection	Rc1/2	Q	✓	✓	✓
			1/2NPT internal thread	R	✓	✓	✓
			Rc1/4	S	✓	✓	✓
			1/4NPT internal thread	T	✓	✓	✓
				-			
				00000			
				-			
Options I	No options		X	✓	✓	✓	
	Lightning arrester		L	✓	✓	✓	
	Built-in indicating smart meter (0 to 100% liner scales)		P	✓	✓	✓	
	Built-in indicating smart meter (engineering unit scales)		R	✓	✓	✓	
	SUS304 bolt and nuts material		W	✓	✓	✓	
	SUS630 bolt and nuts material		U	✓	✓	✓	
	Corrosion-resistant finish		A	✓	✓	✓	
	Corrosion-proof finish		B	✓	✓	✓	
	Corrosion-resistant finish, silver paint		D	✓	✓	✓	
	Oil Free finish		K	✓	✓	✓	
	Long vent/ drain plugs		J	✓	✓	✓	
	FM Explosionproof		3	✓	✓	✓	
	FM Intrinsically safe		4	✓	✓	✓	
	Combination of FM Explosionproof and Intrinsically safe		5	✓	✓	✓	
ATEX Flameproof		6	✓	✓	✓		
ATEX Intrinsic safety		7	✓	✓	✓		
CSA Explosion-proof		8	✓	✓	✓		
				-	-	-	
Options II	No option		XX	✓	✓	✓	
	Burn-out feature (Lower limit of value at abnormal condition) *2		A4	✓	✓	✓	
	Burn-out feature (Upper limit of value at abnormal condition) *2		A5	✓	✓	✓	
	Water free finish (with oil free finish)		A7	✓	✓	✓	
	NEPSI Flameproof		C1	✓	✓	✓	
	NEPSI Intrinsically safe		C2	✓	✓	✓	
	Custom calibration		C7	✓	✓	✓	
	Digital output *38		D5	✓	✓	✓	
	HART communication *5 *38		D7	✓	✓	✓	
	One elbow		E1	✓	✓	✓	
	Two elbows		E2	✓	✓	✓	
	External zero/span adjustment		E5	✓	✓	✓	
	Mounting bracket		E9	✓	✓	✓	
	PED (97/23/EC) conformity *34		H1	✓	✓	✓	
	Material certificate		H2	✓	✓	✓	
	Max. working pressure 20 MPa *37		H3	✓	✓	✓	
	SI unit		U1	✓	✓	✓	

Note) *1 SCS14A (Equivalent SUS316) or SUSF316

*2 The output current value ranges from 3.0 to 3.8 mA for the lower limit and from 20.8 to 21.8 mA for the upper limit.

*3 In case "For oxygen or chlorine (Fluorine oil) service" is used, it's recommended to select "oil free finish - code K"

*5 Intrinsically safe for NEPSI approval cannot be selected with -D7.

*12 When SUS304 bolt/nut is selected, max. working pressure rating is 23 MPa {230 kgf/cm²}

*34 "PED conformity" is not applicable for the combination with FM, CSA or NEPSI approvals.

*37 Not applicable for the combination with "PED conformity"

*38 Either one of "Digital output - code D5" or "HART communication -code D7" can be selected at a time.

ST3000 series 900 electric differential pressure transmitter

Model STD961 (High static pressure type for super-high differential pressure)

Model No.: STD961 - I II III - 00000 - Option I - Option II

Basic Model No.

Measuring span	0.25 to 14 MPa (2.5 to 140 gf/cm ²)	STD961
----------------	---	--------

Selection I			Code	Material code			
I	Material	Meter body cover	Vent / drain plugs	Wetted parts of center body	A	E	9
		Carbon steel	SUS316	Diaphragm: SUS316L Others: SUS316	A		
		SCS14A*1	SUS316	Diaphragm: SUS316L Others: SUS316	E		
		Carbon steel Ni plating	SUS316	Diaphragm: SUS316L Others: SUS316	9		
II	Fill fluid	Regular type (Silicone oil)		1	✓	✓	✓
		For oxygen service (Fluorine oil) *3		2		✓	
III	Process connection	Top or bottom connection	Rc1/2	Q	✓	✓	✓
			1/2NPT internal thread	R	✓	✓	✓
			Rc1/4	S	✓	✓	✓
			1/4NPT internal thread	T	✓	✓	✓
			-	00000			
Options I			No options	X	✓	✓	✓
			Lightning arrester	L	✓	✓	✓
			Built-in indicating smart meter (0 to 100% liner scales)	P	✓	✓	✓
			Built-in indicating smart meter (engineering unit scales)	R	✓	✓	✓
			SUS304 Bolt and nuts material	W	✓	✓	✓
			SUS630 Bolt and nuts material	U	✓	✓	✓
			Corrosion-resistant finish	A	✓	✓	✓
			Corrosion-proof finish	B	✓	✓	✓
			Corrosion-resistant finish, silver paint	D	✓	✓	✓
			Oil free finish	K	-	✓	-
			Long vent/ drain plugs	J	✓	✓	✓
			FM Explosionproof	3	✓	✓	✓
			FM Intrinsically safe	4	✓	✓	✓
			Combination of FM Explosionproof and Intrinsically safe	5	✓	✓	✓
			ATEX Flameproof	6	✓	✓	✓
			ATEX Intrinsic safety	7	✓	✓	✓
			CSA Explosion-proof	8	✓	✓	✓
			-	XX	✓	✓	✓
Options II			No option	XX	✓	✓	✓
			Burn-out feature (Lower limit of value at abnormal condition) *2	A4	✓	✓	✓
			Burn-out feature (Upper limit of value at abnormal condition) *2	A5	✓	✓	✓
			Water free finish (with oil free finish)	A7		✓	
			NEPSI Flameproof	C1	✓	✓	✓
			NEPSI Intrinsically safe	C2	✓	✓	✓
			Custom calibration	C7	✓	✓	✓
			Digital output *38	D5	✓	✓	✓
			HART communication *5 *38	D7	✓	✓	✓
			One elbow	E1	✓	✓	✓
			Two elbows	E2	✓	✓	✓
			External zero/ span adjustment	E5	✓	✓	✓
			Mounting bracket	E9	✓	✓	✓
			PED (97/23/EC) conformity *34	H1	✓	✓	✓
			Material certificate	H2	✓	✓	✓
			Max. working pressure 20 MPa *37	H3	✓	✓	✓
			SI unit	U1	✓	✓	✓

Note) *1 SCS14A (Equivalent SUS316) or SUSF316

*2 The output current value ranges from 3.0 to 3.8 mA for the lower limit and from 20.8 to 21.8 mA for the upper limit.

*3 In case "For oxygen or chlorine (Fluorine oil) service" is used, it's recommended to select "oil free finish - code K"

*5 Intrinsically safe for NEPSI approval cannot be selected with -D7.

*12 When SUS304 bolt/nut is selected, max. working pressure rating is 23 MPa {230 kgf/cm²}

*34 "PED conformity" is not applicable for the combination with FM, CSA or NEPSI approvals.

*37 Not applicable for the combination with "PED conformity"

*38 Either one of "Digital output - code D5" or "HART communication -code D7" can be selected at a time.

DIMENSIONS

Model STD910 / STD960

Process connection: Front side

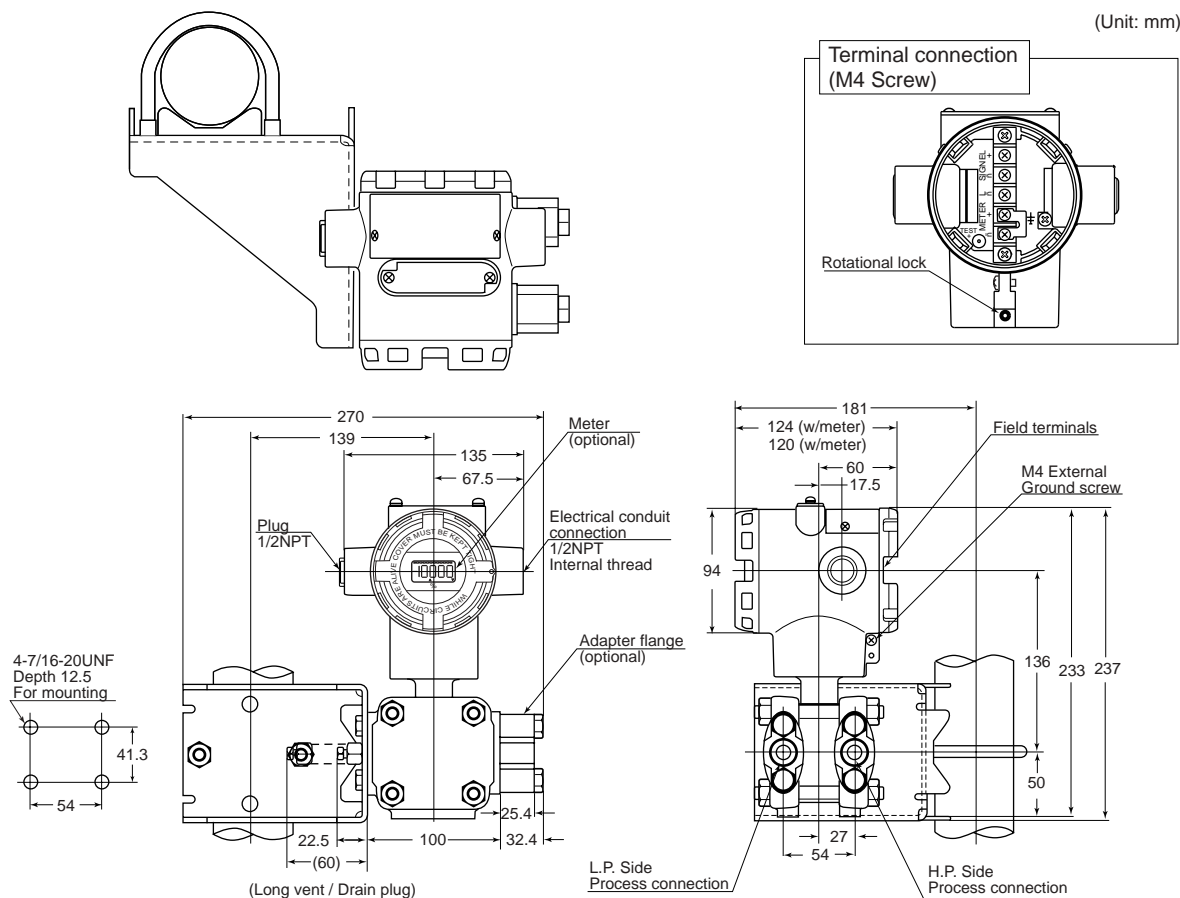

Process connection: Top or bottom side

*Meter unit inside of transmitter can be rotated for the following installation.

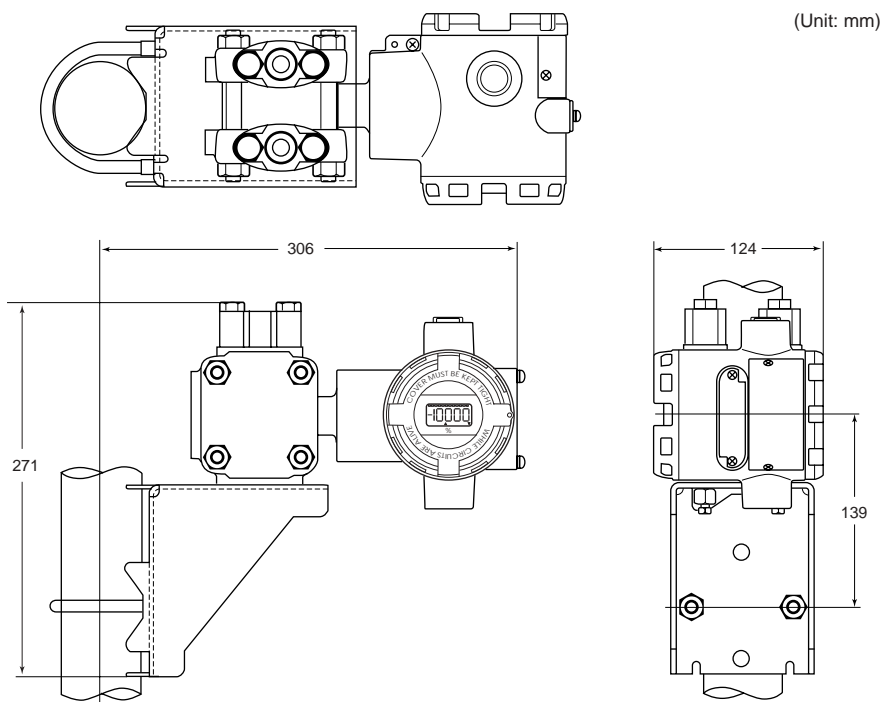

Model STD920 / STD930

Process connection: Front side

(Unit: mm)

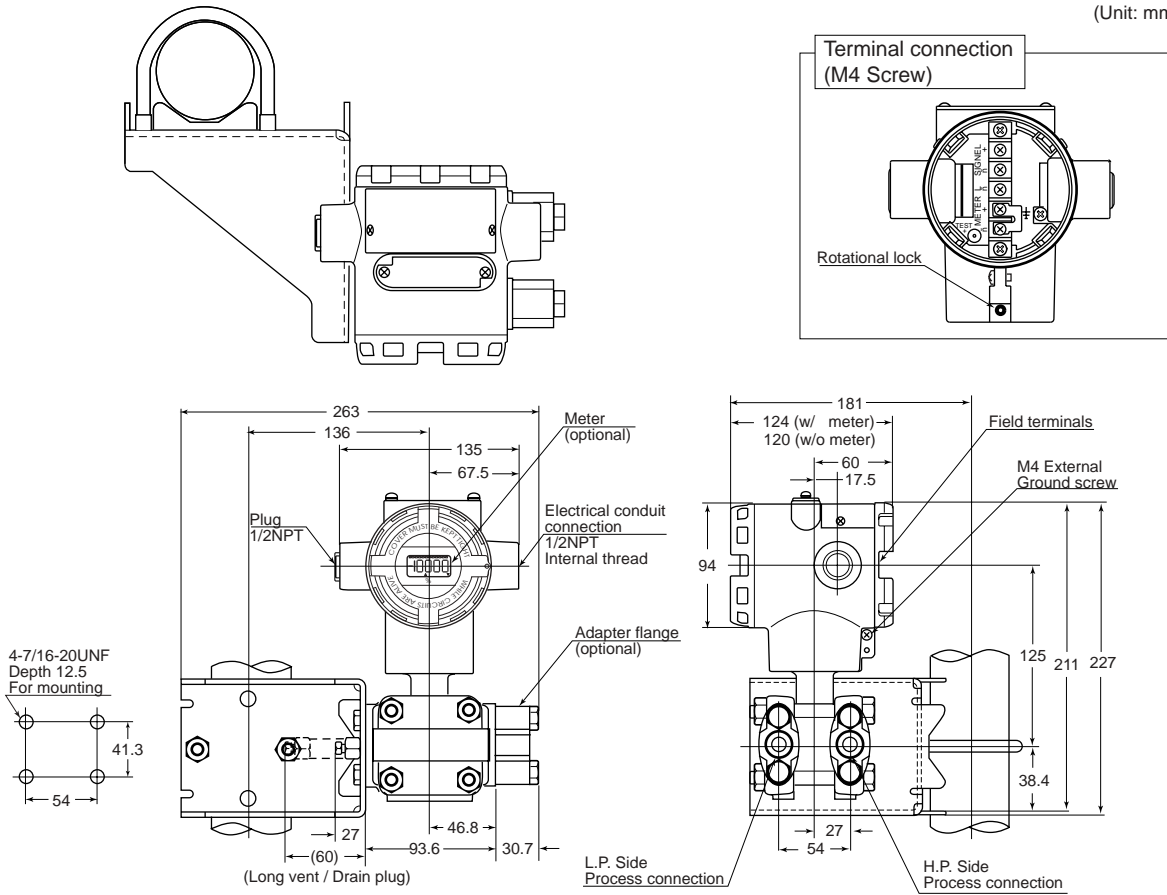

Process connection: Top or bottom side

*Meter unit inside of transmitter can be rotated for the following installation.

(Unit: mm)

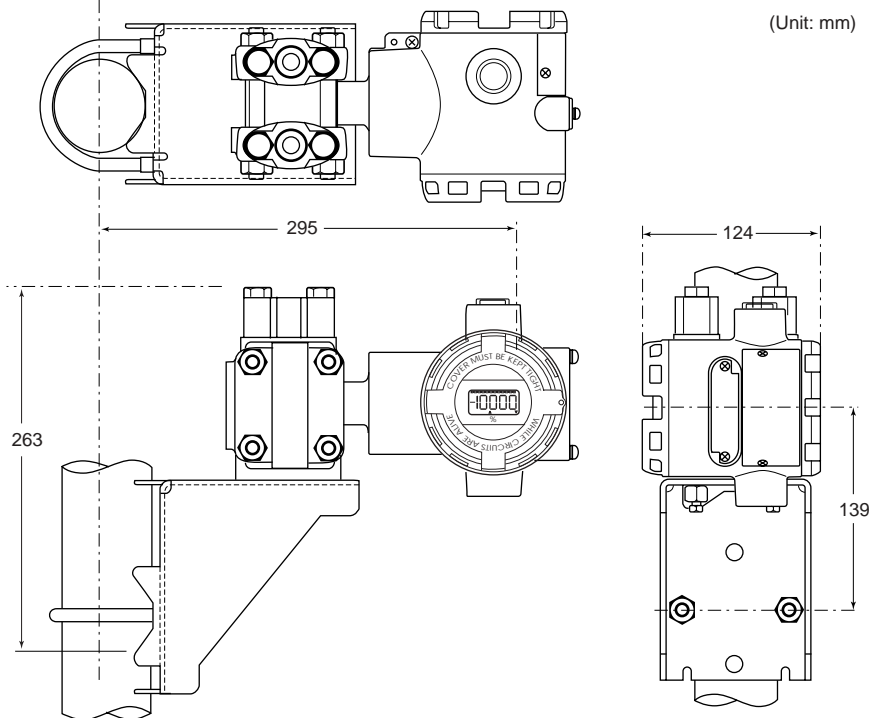

Model STD921 / STD931 / STD961

Process connection: Top or bottom side

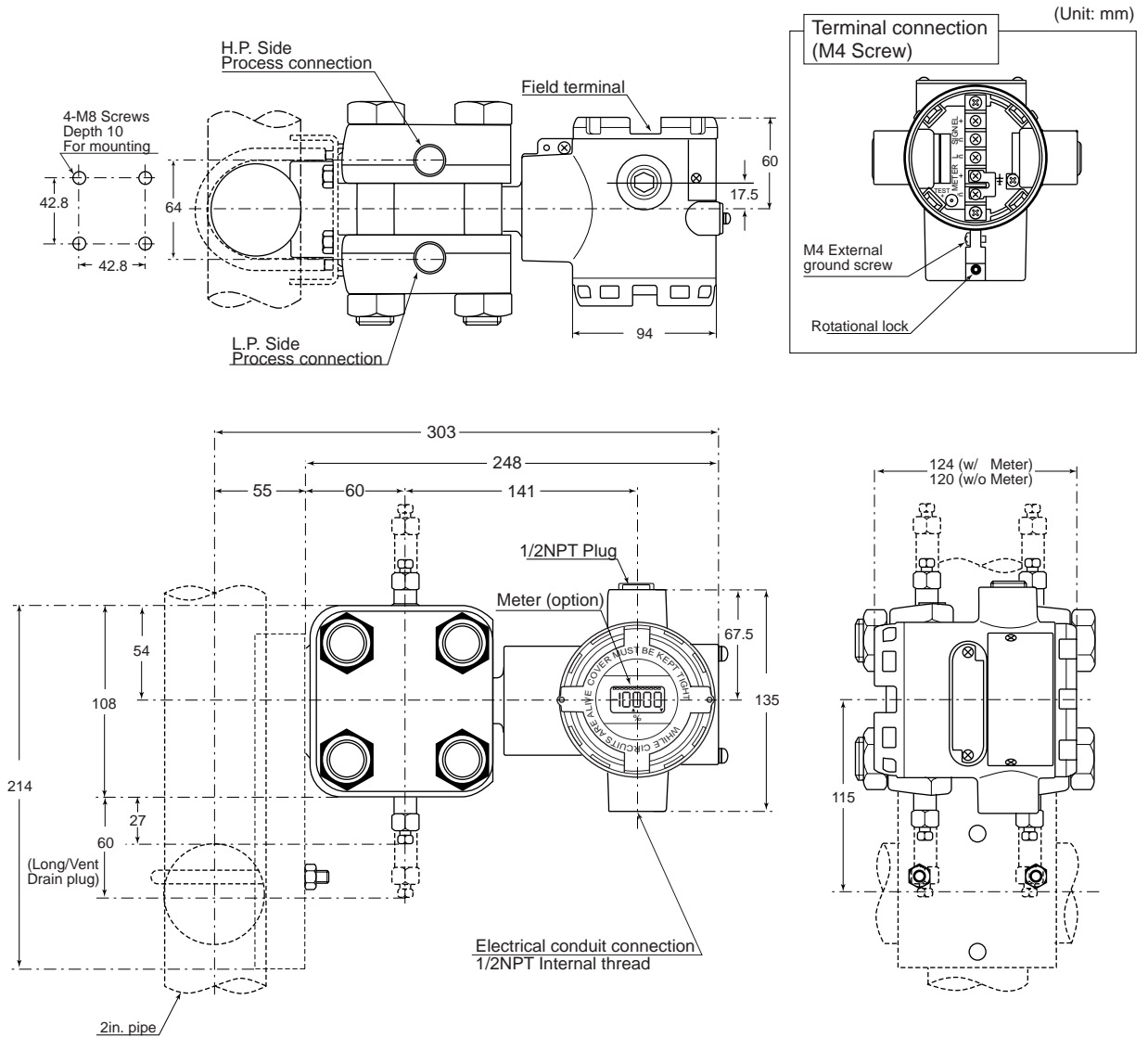

Model STD920 (Wetted parts materials: Tantalum, SUS316L)

Model STD930 (Wetted parts materials: Tantalum, SUS316L)

Model STD960 (Wetted parts materials: Tantalum, Hastelloy C)

Process Connection: Top or bottom side

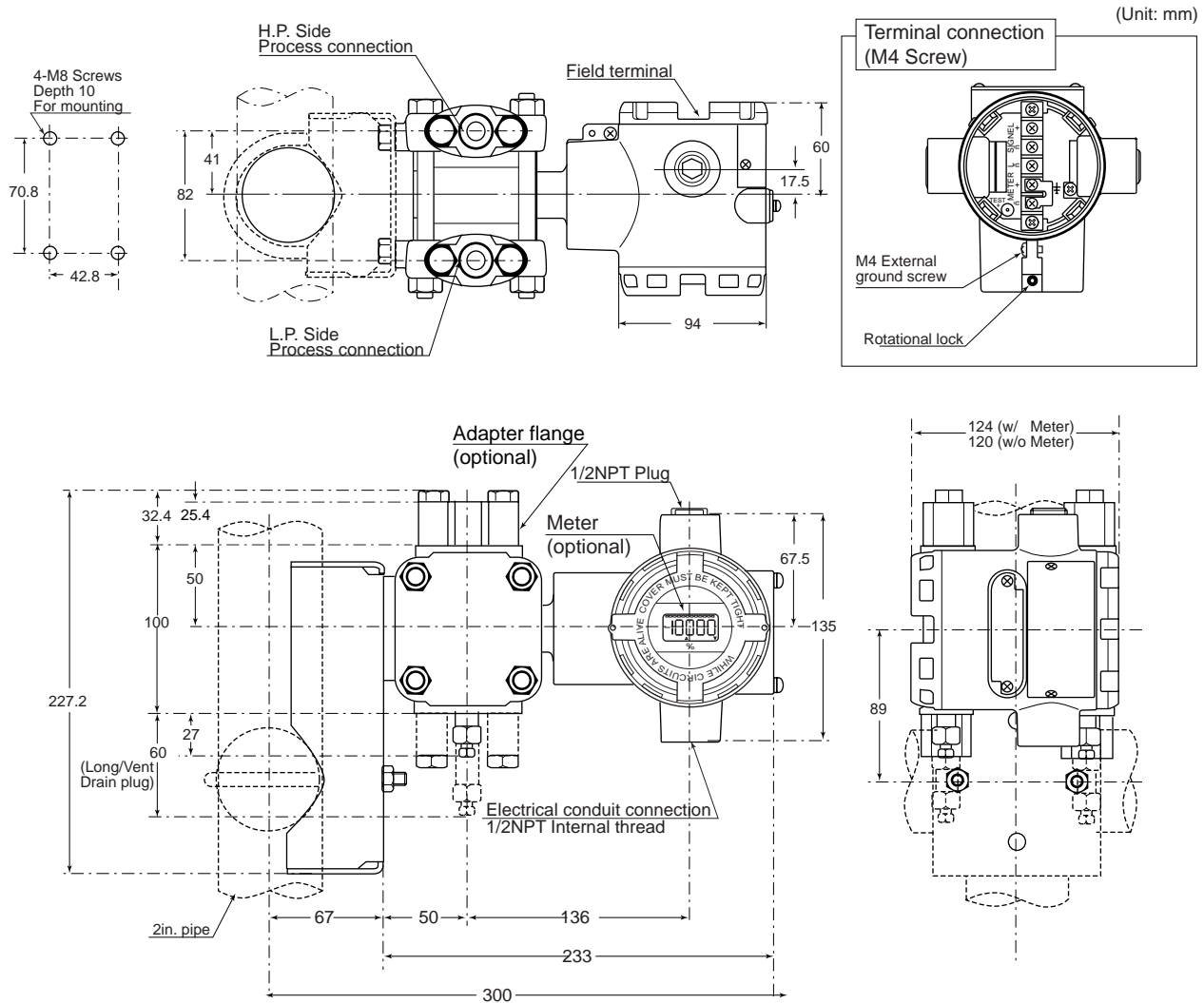

Note

Yamatake Corporation

Totate international Building
2-12-19 Shibuya
Shibuya-ku, Tokyo 150-8316
Japan

Tel : 81-3-3486-2310

Fax : 81-3-3486-2593



Certificate No. Q17862

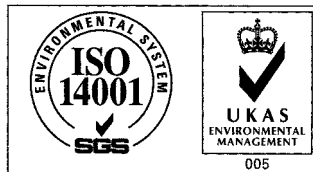

Certificate No. E8318
For Shonan Factory

YAMATAKE
Savemation

Saving through Automation