

Smart Displacement type Level Transmitter

Model SLX

OVERVIEW

The SLX series is a complete line of highly accurate and reliable high-performance torque tube type displacement level transmitters for the measurement.

The model SLX is able to calculate boundary surface levels, specific gravity as well as liquid level. Buoyancy is transmitted as either a 4 - 20mA DC analog signal or a DE protocol digital signal.

These microprocessor-based instruments have two-way communication capabilities that makes possible communication with the SFC (Smart Field Communicator) or DCS (Distributed Control System) with a SLX data base. Tasks such as self-diagnosis or range or zero/span adjustment can, thus, be performed remotely.



FEATURES

Economical replacement

- The model SLX can be fitted with a existing chamber and float making it an economic investment.

Wide selection of element material

- Select from various kinds of materials for wetted parts to best suit your individual application.
- A wide range of allowable operating pressures and specific gravities is available to choose from.

High performance and highly reliable

- Specific gravity for the process fluid can be set from the SFC.
- The effect of transient temperature is minimal.

Easy to adjust and maintain

- Remote setting of range, self-diagnosis, zero/span adjustment can be made from the SFC.
- Exact, dumping and zero/span adjustments can be made by just using a screwdriver without having to open the meter cover.

- An LCD display indicator makes it easier to monitor liquid level and output.

Compatible housing and parts

- Field proven chamber and float
- The transmitter housing is common use with our differential pressure transmitter.
- Highly resistant to vibration

Multi-protocol communication

- Outputs 4 - 20mA analog and DE protocol digital signals.
- Two-way digital communication enables tasks such as self-diagnostics, range adjustment, and precise calibration of the transmitter.

APPLICATIONS

- Reactor, distillation, drum, recovery level measurement
- Boundary surface, specific gravity measurement
- Cryogenic (-196°C liquefied gas etc.) and high-temperature (+ 400°C) applications
- High-vacuum (-101.3 kPa) and high-pressure (15 MPa) applications

OPERATION PRINCIPLE

One side of the torque tube is fixed onto the torque tube housing with screw. And the other side of the torque tube is assembled with torque arm, which is supported at the knife-edge supporting point. When installing or using the level measurement, suspend the float on the edge of the torque arm, and then the torque tube will be twisted by the float's weight. Use the level measurement in this condition.

When process liquid level changes, buoyancy will generate on the float according to the “Principle of Archimedes”. (Displacement type float is heavy. Therefore, float displacement may not change the level despite of the liquid level change. In general, it is designed as to be “generated buoyancy of liquid level at 100% < float mass”). The proportionally generated buoyancy to the level, converts into torque by torque arm/knife-edge which suspends the float, and to the torque tube. Torque tube functions as to enclose the process liquid and as torsion spring function, and converts torque into angle displacement. This angle displacement transfers through torque rod and coupling, and detected by the angle displacement sensor. Then, it will be converted into liquid level signal by A/D converter, and sent it to CPU.

In case the process liquid contacts with torque tube, the shearing module of the torque tube material will be changed by liquid temperature, and then changes the torsional spring constant, and generates the output shift. To compensate the output shift, which generates by liquid temperature, temperature around the torque tube is detected by the temperature sensor, converted into temperature signal by A/D converter and then sent to CPU.

These liquid level signal and temperature signal are computed by CPU, and become digital signal based on each configured range by SFC. This computed value will be converted into 4 to 20mADC analog signal with D/A converter and will be output.

Moreover, model SLX is provided parameters to compensate the output shift which generates by liquid temperature. (Default parameters are set at shipment, can be set using SFC later.)

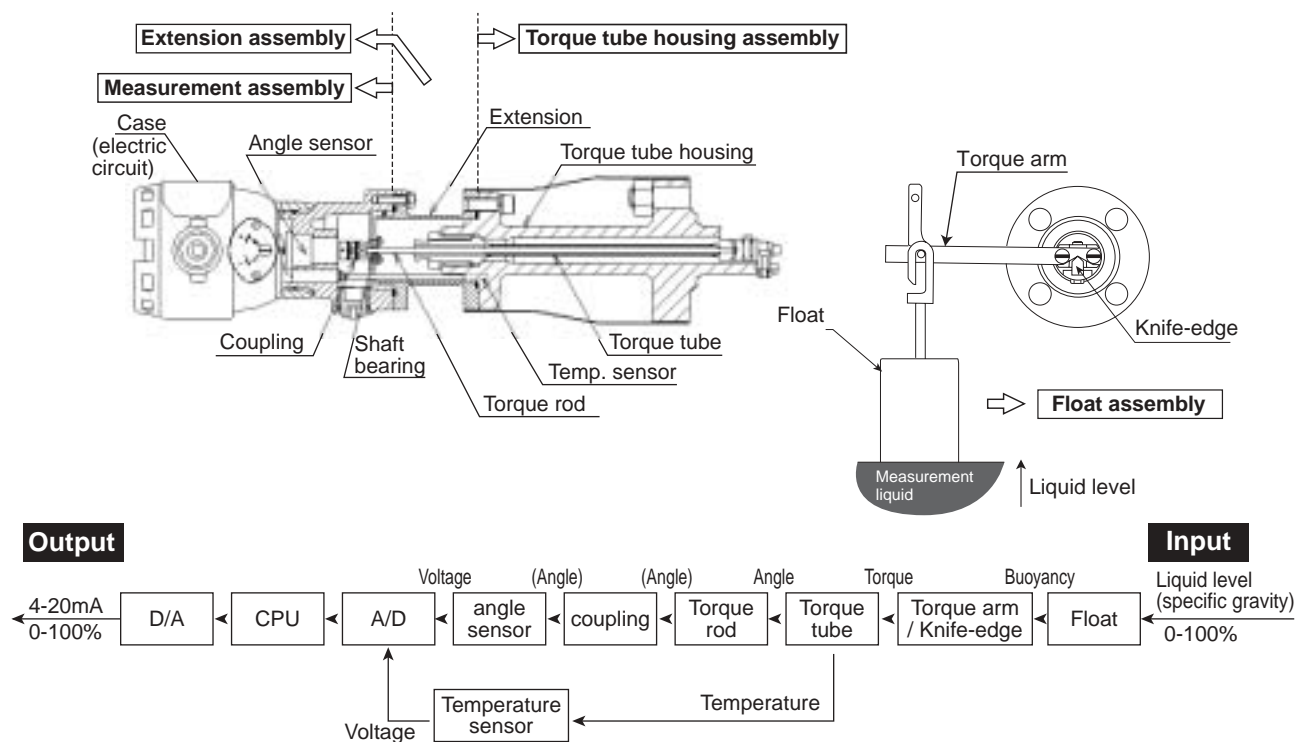

Figure 1 Model SLX - Structure of signal route and signal block diagram

FUNCTIONAL SPECIFICATIONS

Measuring range.

Table 1 Model SLX measuring ranges

Range (mm)	Measuring and setting range (mm)
0 to 300	Set applicable within the range shown left
0 to 350	
0 to 400	
0 to 450	
0 to 500	
0 to 600	
0 to 700	
0 to 800	
0 to 1000	
0 to 1200	
0 to 1500	
0 to 2000	

Range of specific gravity

- For level measurement: 0.1 to 1.6
- For boundary surface measurement, see the following.
When the specific gravity of upper layer liquid is γ_2 , and lower layer liquid is γ_3 ,
 $\gamma_2 < \gamma_3$, $0.4 \leq \gamma_2$, $\gamma_3 \leq 1.6$, $0.1 \leq \gamma_3 - \gamma_2 \leq 1.2$
See Figure 2

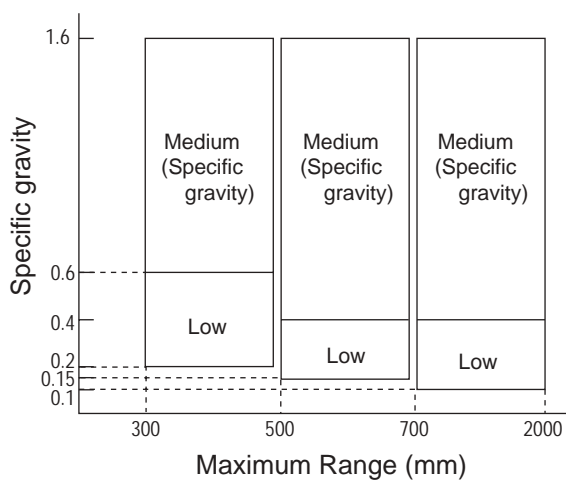

Figure 2 Range of Specific gravity

- Medium: Up to JIS63K, ANSI/JPI600 are available as standard
- Low: Up to JIS30K, ANSI/JPI300 are available as standard

If a range beyond those listed here is required, please consult with a Yamatake sales representative.
For details, see Table 4 and Table 5.

Output / Communication

Analog output (4 to 20mA DC, min. 3.8mA, max. 20.8mA)
Digital output (DE protocol)

Burn-out on failure

(Three optional directions can be selected)
No output burnout
Output burnout to upscale (over 20.8mA)
Output burnout to down-scale (under 3.8mA)

Supply voltage and load resistance

18.5 to 45V DC. A load resistance of 250 Ω or more is necessary in a loop. See Figure 3.

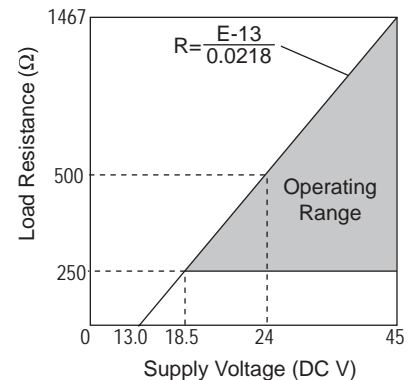

Figure 3 Power supply voltage / load resistance

Note) For communication with SFC, a load resistance of 250 Ω or more is required.

Stability against supply voltage change

$\pm 0.005\%$ F.S./V

Damping time

Selectable from 0 to 100 sec. in increments of ten

Lightening protection characteristics

Voltage surge wave, maximum: 12 kV
Current surge wave, maximum: 1000 A

Operating pressure

-101.3 kPa to each flange rating
Pressure (Up to JIS63K, ANSI/JPI600#, can be extended to ANSI/JIS1900# with certain conditions)
See Table 4 and Table 5.

Operating humidity

5 to 100%RH

Operating temperatures

Table 2 Operating temperatures (°C)

	Ambient temperature	Fluid temperature
Standard operation	23±2	23±2
Normal operation	-30 to 80	-196 to 400
Operative limits	-40 to 85	-196 to 400
Transportation/storage	-40 to 85	-40 to 85

For explosion-proof type or with these having the digital meter option, the temperature ranges are as follows:

With digital indicator (option):

Normal operating range: -20 to 70°C

Operative limits: -30 to 80°C

JIS flameproof type:

Ambient temperature: -20 to 55°C

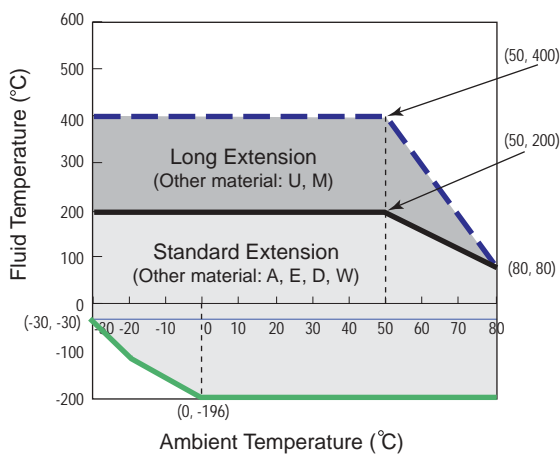

Figure 4 For liquid level of boiler application and boundary surface measurement

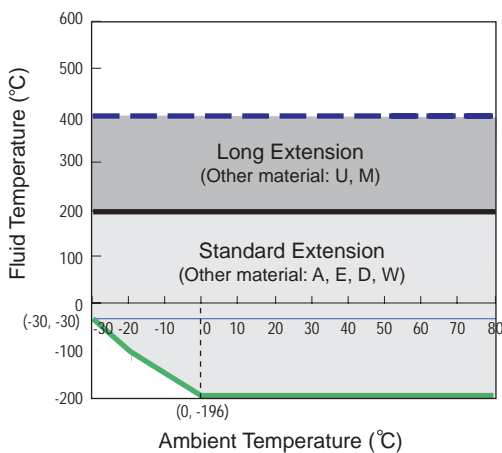

Figure 5 For liquid level measurement other than boiler application

PHYSICAL SPECIFICATIONS

Material

See "Table 6 Material" on page 5.

Case finish

Case

Light beige (Munsell 4Y7.2/1.3)

Cover

Dark beige (Munsell 10YR4.7/0.5)

Weight

Approx. 28 kg (For model SLX110-10551E131-11X-X)

Enclosure rating

Equivalent IEC IP66 / NEMA 4X / JIS C 0920 Watertight

Explosion proof

JIS flameproof (Exd IIC T3, Exd IIC T4, Exd IIC T5, Exd IIC T6)

Table 3 Temperature classifications for explosion-proof

Temperature level	Maximum allowable external temperature*	Atmospheric ignition temperature
T3	+135°C to 200°C	Over +200°C
T4	+100°C to 135°C	Over +135°C
T5	+85°C to 100°C	Over +100°C
T6	85°C or less	Over +85°C

Note) 1. When selecting explosion-proof specifications, please carefully read the following: Industrial Safety Laboratory's Technical Guideline/Factory Explosion-proof Electric Facility Guide (Gas Explosion Proofing 1994), published by Industrial Safety Engineering Institute

Note) 2. When making changes to an existing facility, abide by the explosion proofing construction of the existing devices.

Example: d2G4 → model SLX: ExdIICT4

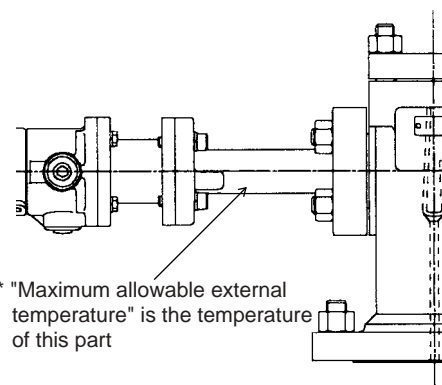

* "Maximum allowable external temperature" is the temperature of this part

Figure 6 Allowable external temperature

Table 4 Float test pressure - Material: SUS316L

Model No.	Measuring range (mm)	Medium specific gravity (model SLX110)				Low specific gravity (model SLX120)				
		Float dia. (mm)	Weight (Kg)	With standing pressure (MPa)	Flange rating	Float dia. (mm)	Weight (kg)	With standing pressure (MPa)	Flange pressure rating (MPa)	
03	0~300	55	1.8	15.0	Up to JIS 63K, ANSI / JPI 600	95	3.4	7.8	Up to JIS 30K, ANSI / JPI 300	
A3	0~350		2.2				3.8			
04	0~400		2.2				4.2			
A4	0~450		2.2				4.2			
05	0~500		2.6				4.6			
06	0~600	45	2.2			85	3.4	3.2		Up to JIS10K, ANSI / JPI 150
07	0~700		2.2				3.8			
08	0~800		2.6				4.2			
10	0~1000		3.0				5.0			
12	0~1200	30	1.8			65	3.8	3.2		
15	0~1500		2.2	4.2						
20	0~2000		3.0	4.2	55		4.2			

Table 5 Float test pressure - Material: Hastelloy C

Model No.	Measuring range (mm)	Medium specific gravity (model SLX110)				Low specific gravity (model SLX120)				
		Float dia. (mm)	Weight (Kg)	With standing pressure (MPa)	Flange rating	Float dia. (mm)	Weight (kg)	With standing pressure (MPa)	Flange pressure rating (MPa)	
03	0~300	55	1.8	7.8	Up to JIS 30K, ANSI / JPI 300	95	3.8	7.8	Up to JIS30K, ANSI / JPI 300	
A3	0~350		2.2				3.4			
04	0~400		2.2				3.8			
A4	0~450		2.2				4.2			
05	0~500		2.6				4.2			
06	0~600	45	2.2			85	4.2	3.2		Up to JIS10K, ANSI / JPI 150
07	0~700		2.2				4.6			
08	0~800		2.6				5.0			
10	0~1000		3.0				5.0			
12	0~1200	30	1.8			65	3.4	3.2		
15	0~1500		2.2	4.2						
20	0~2000		3.0	4.2	55		4.2			

Note) The float weight in the above table is for liquid level application.

For interface or hygrometer applications, below conditions will apply:

1. Medium specific gravity (model SLX110): Identical to the figures above,
2. Low specific gravity application (model SLX120): Depends on customer's specifications. (Weight for liquid level specifications will be the minimum and it will increase depending on customer's specifications)

Table 6 Material

Model (temp. range)	U	M	A	E	D	W
Part	(350 to 400°C)	(200 to 350°C)	(0 to 200°C)	(0 to 200°C)	(-196 to 0°C) ^{*i}	(-40 to 200°C)
Housing	Aluminum alloy					
Torque tube	inconel			SUS316L		Hastelloy C
Bonnet / chamber	Carbon steel (SFVC2A), SUS304, SUS316, SUS316L ^{*ii}					SUS316L
Float	SUS316L					Hastelloy C
Bolt	Chromium-Molybdenum steel (SNB7)				SUS304	
Gasket	Spring type (Semi-metallic, Filler material: Graphite)					
Extension	SUS304 (Long)			SUS304 (Standard)		
Sensor housing	Aluminum alloy casting					

Note) ^{*i}. Available at the range of 0 to 200°C.

Note) ^{*ii}. If the optional code is "D", carbon steel cannot be selected.

INSTALLATION**Electrical conduit**

G½ internal thread, ½NPT internal thread (JIS flameproof is not applicable)

Grounding

Resistance 100 Ω max.

Wiring connection

Wiring terminals screw (M4, SUS304)

Process connection

Flange

External chamber type**Connection**

Side - Side
Side - Bottom
Top - Side
Top - Bottom

Flange size

2 in. or 1½ in. RF (ANSI / JPI 600)
2 in. or 1½ in. RTJ (ANSI/JPI 600)

Internal float type**Connection**

Top

Flange size

3, 4, or 5 in. RF (ANSI/JPI 600)
3 or 4 in. RTJ (ANSI/JPI 600)

PERFORMANCE**Accuracy rating**

(at load correction under standard operating condition)
+/-0.5% F.S. (for specific gravity, see Figure 2)

Ambient temperature characteristics

(Ambient temperature range: -30 to 80°C, note1)

Zero shift: ± (1.5 × α)% F.S. / 55°C

Span shift: ± (1.5 × α)% F.S. / 55°C

Fluid temperature characteristics

(Fluid temperature range: -196 to 400°C, note 1 and 2)

Zero shift: ± (1.5 × α)% F.S. / 55°C

Span shift: ± (1.0 × α)% F.S. / 55°C

Note) 1) Correction factor “α” changes depending on the mass of measured fluid displaced by float “Mf” when liquid level changes from 0 to 100%. (In case model number is model SLX110, and its measurement range is 300 mm, and specific gravity is 1, “α” will be 1.)

$$\alpha = \frac{709}{Mf}$$

$$Mf = \frac{(\pi/4) \times D^2 \times H \times \gamma \times \rho_{std} \times 10^{-3}}{1 + 5.76 \times 10^{-7} \times \pi \times D^2 \times \gamma \times \rho_{std}}$$

Wherein:

D: Float diameter (mm)

H: measuring range (Float length is standard, mm)

γ: Specific gravity of measuring liquid

ρ_{std}: Standard density, *ρ_{std}* = 1 (g/cm³)

π: Circle ratio

Note) 2) Only for liquid surface measurement, when temperature correction coefficient: a variable parameter to reduce the operating influence from the process temperature, is 1.0 (default value at shipment) (Not applicable for boundary surface level measurement)

OPTIONAL SPECIFICATIONS

Corrosion-resistant finish

Standard

Baked acrylic finish

Corrosion-resistant finish

Baked acrylic finish, fungus-proof finish

Corrosion-proof finish

Baked epoxy finish, fungus-proof finish

Built-in indicator

- Digital LCD indicator (optional)
- Digital actual scale (SI unit) available
- Liquid level display (% , mm)
- Specific gravity display
- Available to set from -3000 to 3100 (limit of resolution is 0.1) (4.5 digits) arbitrary. For actual scale, specify the following items when ordering.
- Actual scale range
- Actual scale unit (mm)

Each setting are executed using SFC. (However, version 8.0 or later)

Elbow

This is an adaptor to match the electric conduit connection to field wiring conditions, from horizontal to vertical visa versa. One or two can be selected depending on the field installation requirements.

Oil-free / Water-free treatment (only for SUS material)

Measuring range of 1000 mm or less:

Delivered after eliminating oil and water from wetted surface.

Oil-free treatment (only for SUS material)

Measuring range of 1000 mm or less:

Delivered after eliminating oil from wetted surface.

Test report

This report gives the results of testing, including the external appearance of the liquid level meter, input / output characteristics (3 points), insulation resistance and with-standing voltage tests.

Five points check

The measuring point of input / output characteristics described on the test report is changed from 3 points (0, 50, 100%) to 5 points (0, 25, 50, 75, 100%)

Traceability certificate

This report consists of three parts; a measurement management system chart, a calibration certificate and a test report.

Mil sheet

Test results of chemical composition, heat treating conditions and mechanical properties of main materials (torque tube housing, bonnet, chamber) will be submitted as certificate.

Color check

Result of color check penetration test for welding faults on main materials (bonnet, chamber) will be submitted as certificate.

Without float

(Please contact to sales representative)

Float will not be provided.

Please specify if reusing an existing Yamatake float having the model number NQ□31□, NQI21□, KQP□1□, KFL□00-□1, NQP31□ or NQP21□.

Without chamber

(Please contact to sales representative)

Chamber will not be provided.

Please specify if reusing an existing chamber having the model number NQI31□, NQI21□, KQP□1□, KFL□00-□1, NQP31□ or NQP21□.

SEMI-STANDARD SPECIFICATIONS

1. Stainless steel bolt (Y131):

For this feature, SUS304 bolts are used for main body assembly. This will be a certified product under High Pressure Gas Law. If the connecting size is JIS10K, NAS1150 or JPI150, please consult with a Yamatake representative.

2. Silver corrosion proof (acrylic) paint (Y138D)

For the prevention of temperature rise by sunlight or radiation heat, as well as protection against corrosive atmosphere. (Note: This does not apply to alkali atmosphere)

3. High pressure gas certification (Y2054)

Please refer to the following for scope of manufacture: Scope of liquid level instrument manufacture as certified by Minister for high pressure gas types:

- 1)-1 Title of certification: Liquid level measurement, float type (including welding construction)
- 1)-2 Scope of certified specifications:
Refer to Table 7 "Scope of certified specifications" for design temperatures, pressures and connecting sizes.
- 1)-3 The listing in Table 7 shows scope of certified specifications, not a scope of certified liquid level meter manufacturing. The scope of manufacture of the certified liquid level meter is within the temperatures and pressures listed in the Spec. Sheet.

Table 7 Scope of certified specifications

Certificate No.	MAB-342-0-2				Type of equipment	Other accessories		
	Material		Design temperature			Design pressure (Mpa)	Connecting dia.(A)	Others
	Class	Group	Max. °C	Min. °C				
Liquid level meter (Buoyancy type)	Carbon steel	G4	450	-10 *	Under 6.4	Under 125		
	Stainless steel	G1	400	-196	Under 6.4	Under 125		
		G4	800	-269	Under 6.4	Under 125		
		G6	800	-196	Under 6.4	Under 125		

Note) * When using SF440A. However, the standard material is SFVC2A, temperature will be "0°C or higher".

Attention in usage

- Yamatake standard Displacement type level transmitter measurement range is set equivalent to float length H. Therefore, it will be unsuitable when detecting the levels around 0% or 100% (at normal operation), or when continuous output of 4mA or less or 20mA or more is needed.
- When conducting the actual liquid adjustment (filling adjustment) after installing the displacement type level transmitter at the job site, be sure to set the float bottom to zero point (reference point at 0% liquid level). (Structurally, if the measurement fluid is not in contact with float, output will not change.)
If other than the float bottom is set to zero point (reference point at 0% liquid level), it may cause the measurement dead-band at the measurement range of lower limit (or upper limit), or may cause output linearity error.

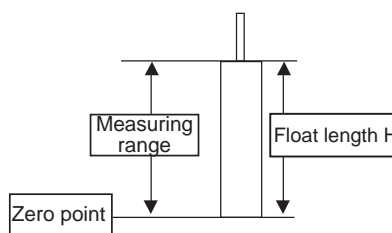

Figure 7 Appropriate way of adjustment: Set float bottom at zero point

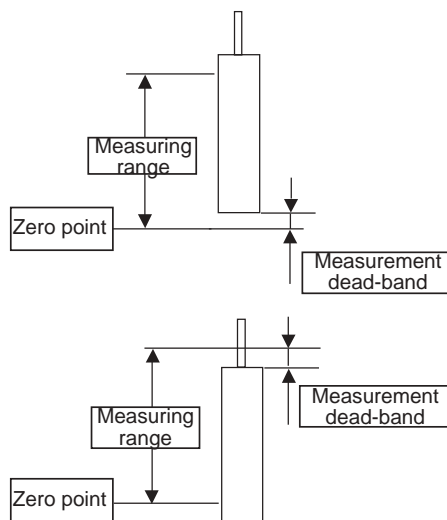

Figure 8 Inappropriate way of adjustment: set other than the float bottom at zero point

SFC Operation

Parameter setting

- (1) Damping: 0~100 sec.
- (2) Specific gravity: 0.1~1.6 ^{*Note}
- (3) Burnout: NON, UP, DOWN
- (4) Span: Set freely within specified range

Calibration

- 1. Zero adjustment ^{*1}
- 2. Span adjustment
- 3. Exact adjustment ^{*2}

Note *1) Make sure that this is done after completing installation at the site.

*2) Match the liquid level measurement output with what is being indicated in the glass gauge. Zero can be adjusted to be set to a point anywhere between 0-100% of the range to match.

Display on SFC screen

1. Input liquid level
2. PV value
3. Torque tube temperature
4. Instrument temperature

Calibration

Proofing by SFC using a weight is possible.

Others

Self-diagnostic functions

External adjustment

Use screwdriver (flat screwdriver) from external side of instrument. Zero, span and damping adjustments are possible. Built-in indicator must be selected to use this adjustment.

Note) Change of specific gravity range

- It is necessary to define the specific gravity of the liquid to be measured in order to manufacture the model SLX correctly. However, range change with an SFC will suffice for range setting change for the ranges listed below.
- The scope of range change by SFC depends on the float size for medium specific gravity range (model SLX110) / or low specific gravity range (model SLX120). Also, note that there is a limitation on boundary surface measurement (hydrometer) specifications for the low specific gravity meter (model SLX120).

1. Medium specific gravity (model SLX110):

- 1-1. For liquid level measurement specifications, range change is possible within the 'Specific Gravity Range' as given in Table 8 below.

Table 8 Specific gravity range 1

Measuring range (mm)	Allowable specific gravity range γ change by SFC
300 ~ 499	$0.6 \leq \gamma \leq 1.6$
500 ~ 2000	$0.4 \leq \gamma \leq 1.6$

- 1-2. For an boundary surface measurement (hydrometer), range change is possible within the scope given in Figure 2 "Range of Specific gravity".

Table 9 Specific gravity range 2

Measuring range (mm)	Allowable differential specific gravity range $\Delta\gamma$ change by SFC	Range of γ_3 (or γ_5)
300 ~ 499	$0.6 \leq \Delta\gamma \leq 1.6$	$\gamma_3(\text{or } \gamma_5) \leq 1.6$
500 ~ 2000	$0.4 \leq \Delta\gamma \leq 1.6$	$\gamma_3(\text{or } \gamma_5) \leq 1.6$

The parameters are as follows:

- Boundary surface measurement: $\Delta\gamma = \gamma_3 - \gamma_2$, $\gamma_3 > \gamma_2$
Whereas: γ_2 : Specific gravity of upper layer liquid
 γ_3 : Specific gravity of lower layer liquid
- Hydrometer: $\Delta\gamma = \gamma_5 - \gamma_4$, $\gamma_5 > \gamma_4$
Whereas: γ_4 : Upper limit of specific gravity measurement
 γ_5 : Lower limit of specific gravity measurement

2. Low specific gravity meter (model SLX120)

- 2-1. Range change of liquid level meter specification is allowable within the "Range of Specific gravity", as given in Figure 2.

Table 10

Measuring range (mm)	Allowable specific gravity range γ change by SFC
300~499	$0.2 \leq \gamma < 0.6$
500~699	$0.15 \leq \gamma < 0.4$
700~2000	$0.1 \leq \gamma < 0.4$

- 2-2. Boundary surface measurement (hydrometer) specifications have following limitations on range change:

Table 11

Measuring range (mm)	Range change parameter γ_2 , (γ_4)	Range change parameter γ_3 , (γ_5)
300~2000	Up to +10% of specified initial setting value	Up to +5% of initial setting value

- Input $\Delta\gamma$ from the SFC,
- The result of specific gravity range change may fall outside of SS specifications, thereby accuracy cannot be achieved. The accuracy of the meter after range change can be verified by substituting specific gravity γ , with the differential specific gravity $\Delta\gamma$ in the verification equation on page 12.

MODEL SELECTION

Basic model number

Selections

Options

Medium type for specific gravity (0.4 to 1.6):	SLX110	I	II	III	IV	V	VI	VII	VIII	IX	X	XI	XII
Low type for specific gravity (0.1 to 0.4):	SLX120 *1												

Selections

				I	II	III	IV	V	VI	VII	VIII	
I	Output/ Communication	Analog 4 to 20mA output (Standard)		1								
		Digital (DE protocol) output *7		2								
II	Measuring range (mm)	0 to 300		0	3							
		0 to 350		A	3							
		0 to 400		0	4							
		0 to 450		A	4							
		0 to 500		0	5							
		0 to 600		0	6							
		0 to 700		0	7							
		0 to 800		0	8							
		0 to 1000		1	0							
		0 to 1200		1	2							
		0 to 1500		1	5							
		0 to 2000		2	0							
Others		X	X									
III	Connection	External type Side – Side				1						
		External type Side – Bottom				2						
		External type Top – Bottom				3						
		External type Top – Side				4						
		Internal Top L1 length is required when ordering				5						
		Others				X						
IV	Main Materials	Bonnet/ Chamber	Torque tube / Housing (TH)									
		Carbon steel	Carbon steel (unavailable when temperature 0°C or lower)				1					
		SUS304	SCS13A				2					
		SUS316	SCS14A				3					
		SUS316L	SCS16A				4					
		Others				X						
V	Other materials *3 (Temperature range *2)	Torque tube: Inconel (350 to 400°C)						U				
		Torque tube: Inconel (200 to 350°C)						M				
		Torque tube: Inconel(0 to 200°C)						A				
		Torque tube: SUS316L(0 to 200°C)						E				
		Torque tube: SUS316L (-196 to 0°C) *2						D				
		Torque tube: Hastelloy C (-40 to 200°C) Selection of "4" must be given for "IV material"						W				
Others						X						
VI	Pressure rating (Type of Joint)	JIS10K (RF)							1			
		JIS20K (RF)							2			
		JIS30K (RF)							3			
		JIS63K (RF)							4			
		ANSI150 (RF smoothing)							A			
		ANSI150 (RF serration)							B			
		ANSI300 (RF smoothing)							C			
		ANSI300 (RF serration)							D			
		ANSI600 (RF smoothing)							E			
		ANSI600 (RTJ)							F			
		JPI150 (RF)							G			
		JPI300 (RF)							H			
		JPI600 (RF)							J			
		JPI600 (RTJ)							K			
		Others *4)							X			
		VII	Flange size	1½ in. (40 mm)	For external type							1
2 in. (50 mm)	For external type								2			
3 in. (80 mm)	For internal type (medium type only)								3			
4 in. (100 mm)	For internal type								4			
5 in. (125 mm) *1	For internal type (low type only)								5			
Others											X	
VIII	Meter body	Left side									1	
		Right side									2	

(Continued)

(Continued from previous page)

Options

IX	Electrical conduit / Explosion-proof approvals	G $\frac{1}{2}$ / Watertight	X
		G $\frac{1}{2}$ / JIS Flameproof (ExdsIICT3) with 1 pc. of cable gland	1
		G $\frac{1}{2}$ / JIS Flameproof (ExdsIICT4) with 1 pc. of cable gland	2
		G $\frac{1}{2}$ / JIS Flameproof (ExdsIICT5) with 1 pc. of cable gland	3
		G $\frac{1}{2}$ / JIS Flameproof (ExdsIICT6) with 1 pc. of cable gland	4
		G $\frac{1}{2}$ / JIS Flameproof (ExdsIICT3) with 2 pcs. of cable gland	A
		G $\frac{1}{2}$ / JIS Flameproof (ExdsIICT4) with 2 pcs. of cable gland	B
		G $\frac{1}{2}$ / JIS Flameproof (ExdsIICT5) with 2 pcs. of cable gland	C
		G $\frac{1}{2}$ / JIS Flameproof (ExdsIICT6) with 2 pcs. of cable gland	D
		$\frac{1}{2}$ NPT/ Watertight	5
X	Built-in Indicator	None (without external adjustment switch / without explosion-proof)	X
		Scale in % (0 to 100% liner scale)	1
		Engineering unit scale (only "mm" unit)	2
XI	Finish	Standard	X
		Corrosion-resistant finish	A
		Corrosion-proof finish	B

XII	No option	X
	One elbow (left)	1
	One elbow (right)	2
	Two elbows	3
	Oil-free treatment / water-free treatment (only for SUS material) range = 1000 mm or less	4
	Oil-free treatment (only for SUS material) range = 1000 mm or less	5
	Test report *10	6
	Five points check *10	7
	Material certificate	8
	Traceability certificate *10	A
	Color check	B
	Without Float *5)	C
	Without Chamber *6	D

*1~10: Refer to page 12.

DIMENSIONS

External Float type

S-S: Side - Side

[Unit: mm]

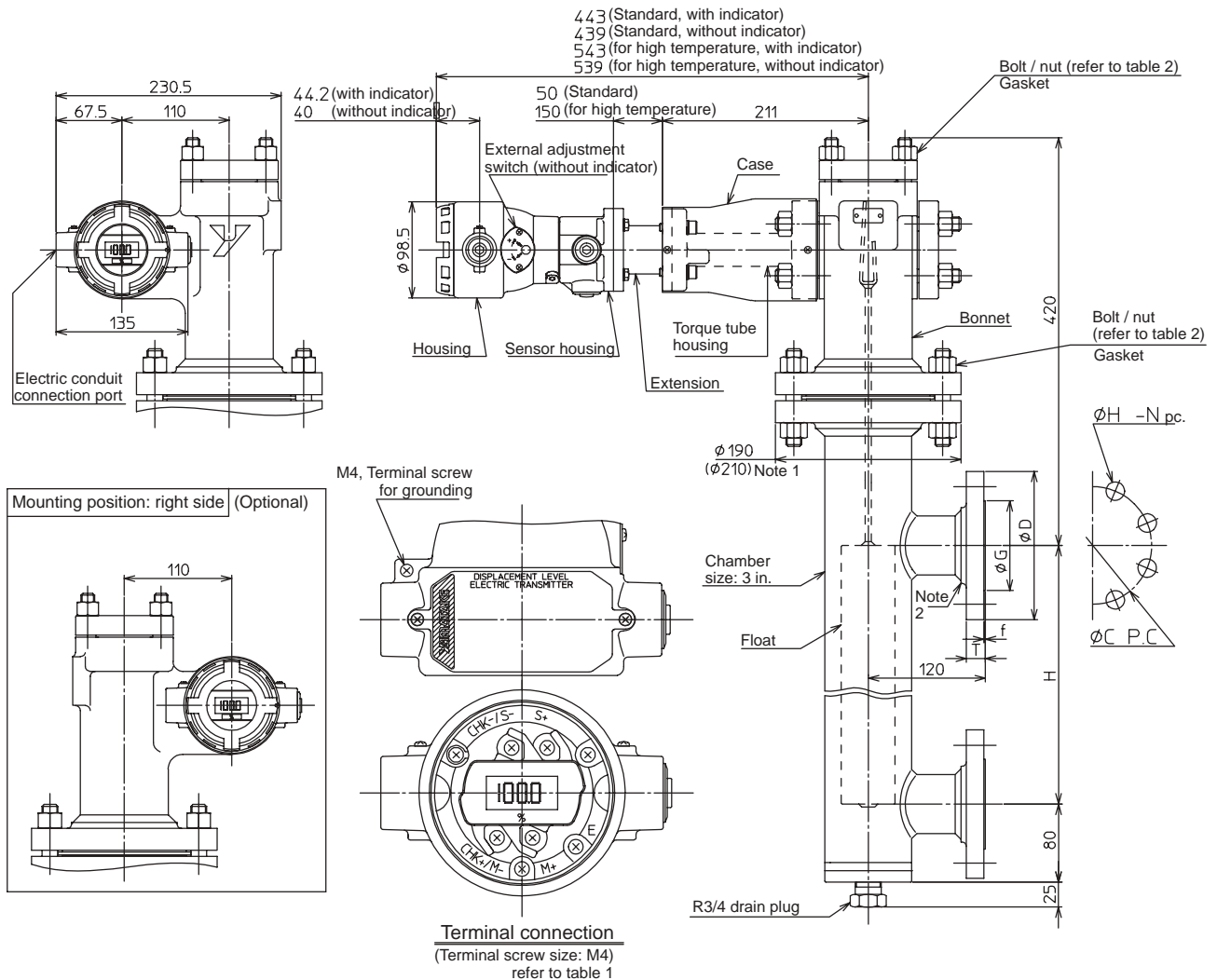

Table 1. Terminal

Symbol	Description
S+, S-	Power supply and output signal terminal
CHK+, CHK-	Terminal for check meter
M+, M-	Terminal for ammeter installed outside
E	Ground terminal

Table 2. Bolt / nut material

	Bolt / nut material
U, M, A, E	SNB7 / S45C *
D, W	SUS304/SUS304

* When Y131 is specified, bolt/nut material shall be SUS304/SUS304.

Table 4. Size H

Measuring range (mm)	H
0-300	300
0-350	350
0-400	400
0-500	500
0-600	600
0-700	700
0-800	800
0-1000	1000
0-1200	1200
0-1500	1500
0-2000	2000

Table 3. Connecting flange size

Flange rating		∅D	∅G	T	f	∅C	∅H-N
40 mm	JIS 10 K RF	140	81	16	2	105	19-4
50 mm		155	96	16	2	120	19-4
1 1/2 in.	JPI 150 RF	127	73.2	18	1.6	98.6	16-4
2 in.		152	91.9	19.5	1.6	120.6	19-4
40 mm	JIS 20 K RF	140	81	18	2	105	19-4
50 mm		155	96	18	2	120	19-8
40 mm	JIS 30 K RF	160	90	22	2	120	23-4
50 mm		165	105	22	2	130	19-8
1 1/2 in.	JPI 300 RF	155	73.2	21	1.6	114.3	22-4
2 in.		165	91.9	22.5	1.6	127	19-8

Note) 1: Dimensions shown inside the bracket is for pressure rating of JIS 20K, JIS 30K, JPI 300 and ANSI 300.

2: When pressure rating is JIS 10K, hub shown in the figure above will not be provided.

S-B: Side - Bottom

[Unit: mm]

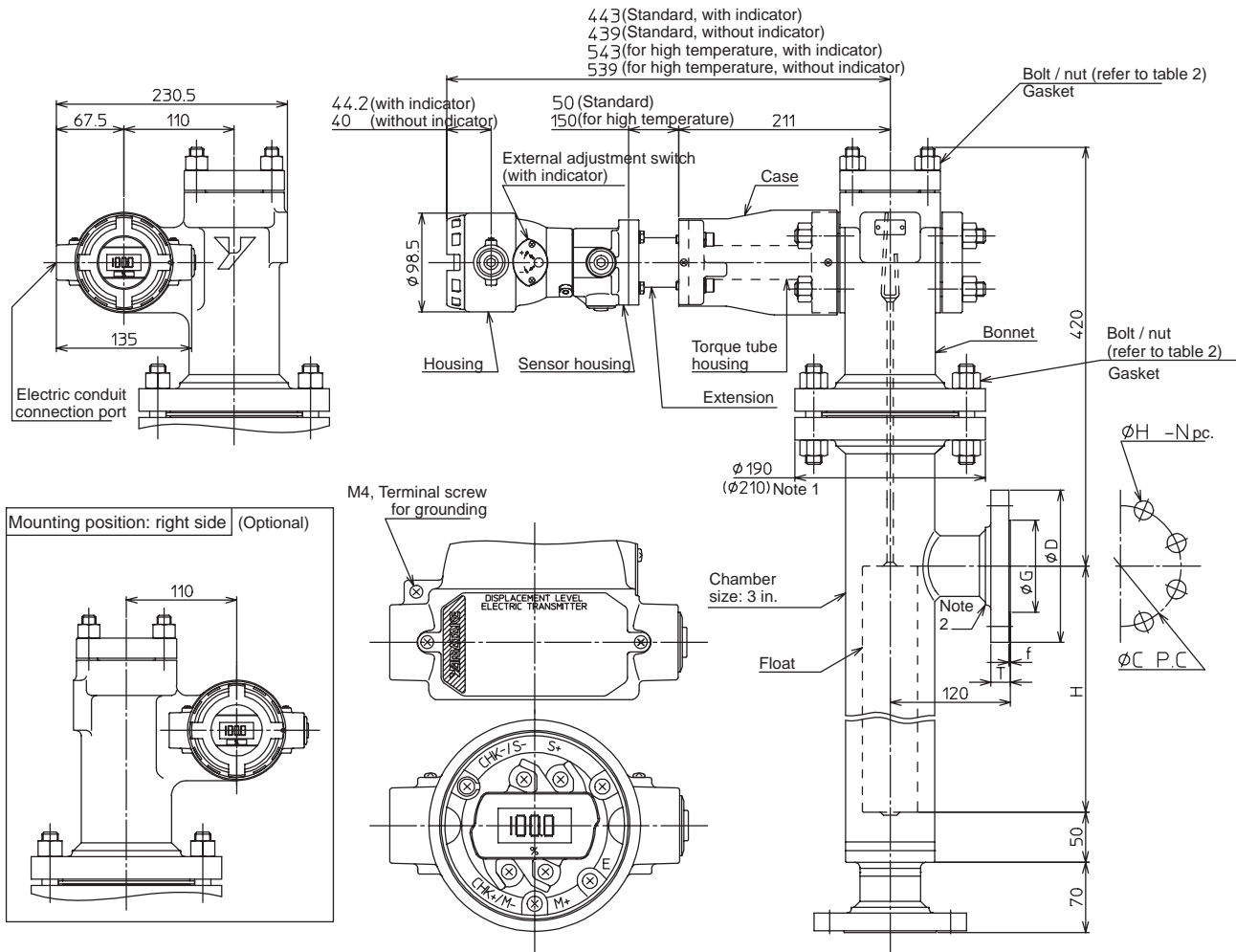

Terminal connection
 (Terminal screw size: M4)
 refer to table 1

Table 1. Terminal

Symbol	Description
S+, S-	Power supply and output signal terminal
CHK+, CHK-	Terminal for check meter
M+, M-	Terminal for ammeter installed outside
E	Ground terminal

Table 2. Bolt / nut material

	Bolt / nut material
U, M, A, E	SNB7 / S45C *
D, W	SUS304/SUS304

* When Y131 is specified, bolt/nut material shall be SUS304/SUS304.

Table 4. Size H

Measuring range (mm)	H
0-300	300
0-350	350
0-400	400
0-500	500
0-600	600
0-700	700
0-800	800
0-1000	1000
0-1200	1200
0-1500	1500
0-2000	2000

Table 3. Connecting flange size

Flange rating		ØD	ØG	T	f	ØC	ØH-N
40 mm	JIS 10 K RF	140	81	16	2	105	19-4
50 mm		155	96	16	2	120	19-4
1 1/2 in.	JPI 150 RF	127	73.2	18	1.6	98.6	16-4
2 in.		152	91.9	19.5	1.6	120.6	19-4
40 mm	JIS 20 K RF	140	81	18	2	105	19-4
50 mm		155	96	18	2	120	19-8
40 mm	JIS 30 K RF	160	90	22	2	120	23-4
50 mm		165	105	22	2	130	19-8
1 1/2 in.	JPI 300 RF	155	73.2	21	1.6	114.3	22-4
2 in.		165	91.9	22.5	1.6	127	19-8

Note) 1: Dimensions shown inside the bracket is for pressure rating of JIS 20K, JIS 30K, JPI 300 and ANSI 300.
 2: When pressure rating is JIS 10K, hub shown in the figure above will not be provided.

T-B: Top - Bottom

[Unit: mm]

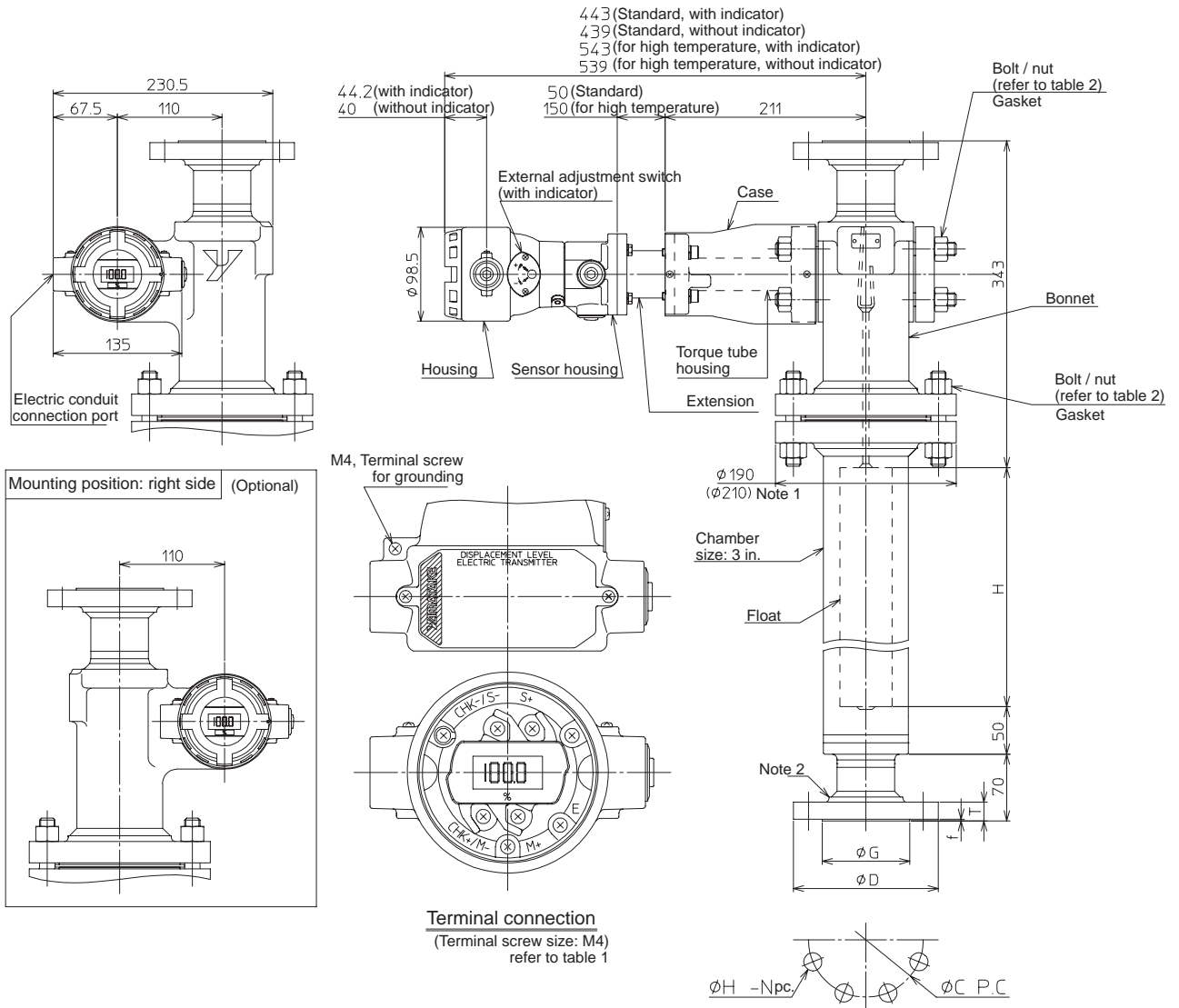

Table 1. Terminal

Symbol	Description
S+, S-	Power supply and output signal terminal
CHK+, CHK-	Terminal for check meter
M+, M-	Terminal for ammeter installed outside
E	Ground terminal

Table 2. Bolt / nut material

	Bolt / nut material
U, M, A, E	SNB7 / S45C *
D, W	SUS304/SUS304

* When Y131 is specified, bolt/nut material shall be SUS304/SUS304.

Table 4. Size H

Measuring range (mm)	H
0-300	300
0-350	350
0-400	400
0-500	500
0-600	600
0-700	700
0-800	800
0-1000	1000
0-1200	1200
0-1500	1500
0-2000	2000

Table 3. Connecting flange size

Flange rating		ØD	ØG	T	f	ØC	ØH-N
40 mm		140	81	16	2	105	19-4
50 mm	JIS 10 K RF	155	96	16	2	120	19-4
1 1/2 in.	JPI	127	73.2	18	1.6	98.6	16-4
2 in.	ANSI 150 RF	152	91.9	19.5	1.6	120.6	19-4
40 mm		140	81	18	2	105	19-4
50 mm	JIS 20 K RF	155	96	18	2	120	19-8
40 mm		160	90	22	2	120	23-4
50 mm	JIS 30 K RF	165	105	22	2	130	19-8
1 1/2 in.	JPI	155	73.2	21	1.6	114.3	22-4
2 in.	ANSI 300 RF	165	91.9	22.5	1.6	127	19-8

Note) 1: Dimensions shown inside the bracket is for pressure rating of JIS 20K, JIS 30K, JPI 300 and ANSI 300.

2: When pressure rating is JIS 10K, hub shown in the figure above will not be provided.

T-S: Top - Side

[Unit: mm]

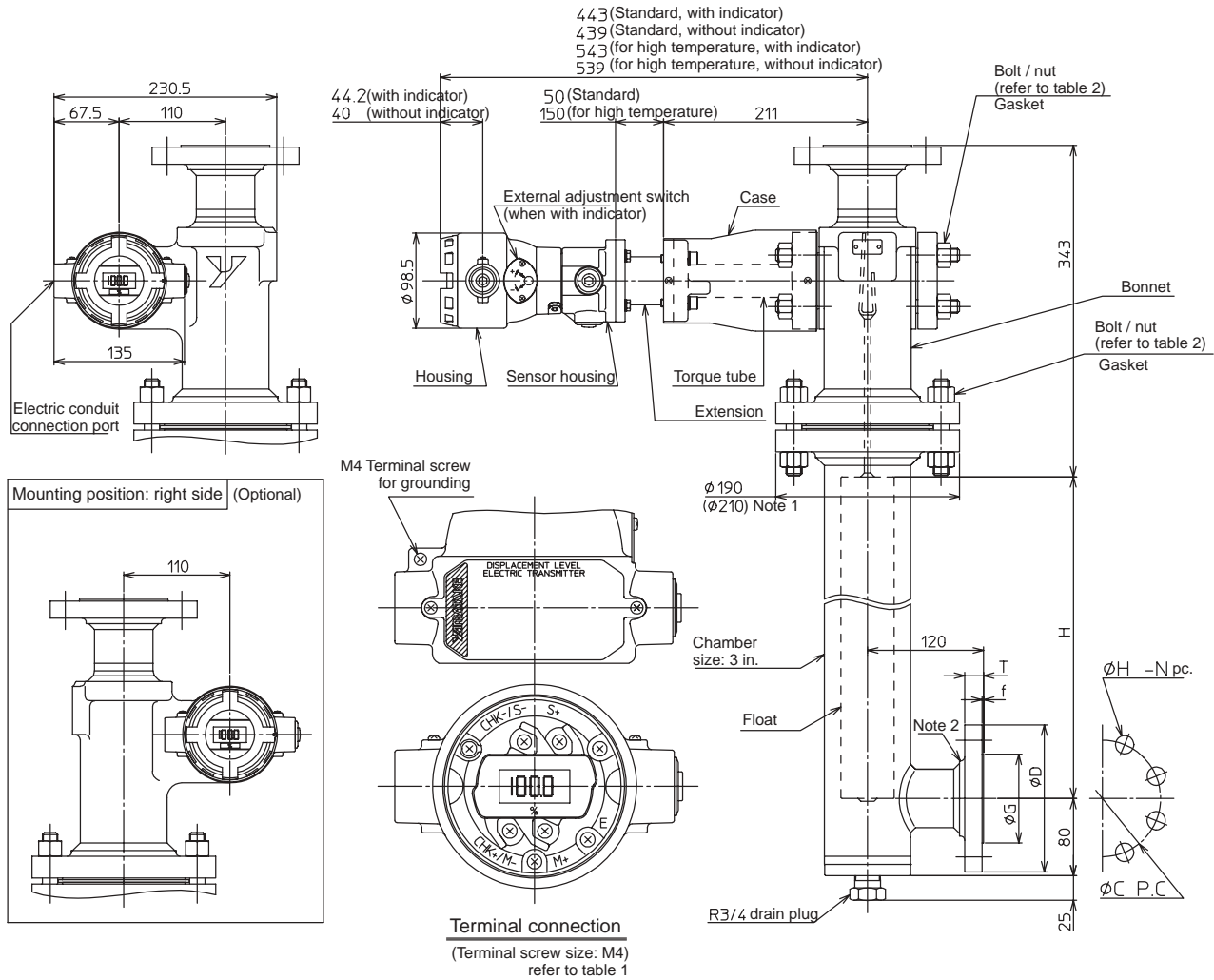

Table 1. Terminal

Symbol	Description
S+, S-	Power supply and output signal
CHK+, CHK-	Terminal for check meter
M+, M-	Terminal for ammeter installed outside
E	Ground terminal

Table 2. Bolt / nut material

	Bolt / nut material
U, M, A, E	SNB7 / S45C *
D, W	SUS304/SUS304

* When Y131 is specified, bolt/nut material shall be SUS304/SUS304.

Table 4. Size H

Measuring range (mm)	H
0-300	300
0-350	350
0-400	400
0-500	500
0-600	600
0-700	700
0-800	800
0-1000	1000
0-1200	1200
0-1500	1500
0-2000	2000

Table 3. Connecting flange size

Flange rating		ØD	ØG	T	f	ØC	ØH-N
40 mm	JIS 10 K RF	140	81	16	2	105	19-4
50 mm		155	96	16	2	120	19-4
1 1/2 in.	JPI 150 RF	127	73.2	18	1.6	98.6	16-4
2 in.	ANSI 150 RF	152	91.9	19.5	1.6	120.6	19-4
40 mm	JIS 20 K RF	140	81	18	2	105	19-4
50 mm		155	96	18	2	120	19-8
40 mm	JIS 30 K RF	160	90	22	2	120	23-4
50 mm		165	105	22	2	130	19-8
1 1/2 in.	JPI 300 RF	155	73.2	21	1.6	114.3	22-4
2 in.	ANSI 300 RF	165	91.9	22.5	1.6	127	19-8

Note) 1: Dimensions shown inside the bracket is for pressure rating of JIS 20K, JIS 30K, JPI 300 and ANSI 300.
 2: When pressure rating is JIS 10K, hub shown in the figure above will not be provided.

Cautions for handling the product

In order to ensure maximum performance from the product's functions, please handle it properly while paying attention to the following precautions. Please make sure that you read the instruction manual of this product before use.

Cautions for installation

⚠ WARNING

- When installing, make sure that the gasket between process connections (flange connections) does not protrude; otherwise fluid leakage or output error may occur.
- Do not operate the instrument beyond the specified pressure, temperature or conditions. Could result in damage to the instrument or fluid leakage which may lead to a serious accident.
- Wiring installation in an explosion-proof area must be done in accordance with the procedures stated in the explosion-proof guideline. For an explosion-proof model with explosion-proof cable gland adaptor, make sure that a Yamatake-made certified explosion-proof cable gland adaptor is used. The cable for wiring should have a 60°C withstanding temperature or higher.*1

*Note *1) If temperature class is as listed below, use cables with higher allowable temperature rating:*

Temp. class	Maximum allowable temperature
T3	70°C
T4	65°C

⚠ CAUTION

- Do not use this instrument as a step or scaffold after installation. The instrument may be damaged and this may result in injury.
- Do not hit indicator's glass window with any tool or hard object. Broken glass may cause the injury.
- Make sure that installation has been performed properly. If not, it may result in output error or violation of industry regulations.
- This instrument is heavy. Be careful on scaffold and wear safety shoes.

⚠ WARNING

- Do not perform wiring with wet hands or while the power supply is on. This may result in electric shock.

⚠ CAUTION

- Make sure that wiring is done properly and checked thoroughly. Incorrect wiring may damage the instrument.
- Make sure that the power supply conforms to specifications and is used properly. An incorrect power supply will damage the instrument.

When ordering, please specify each of the following:

- 1) Model number (attach suffix "Z" to the end of basic model number for hydrometer.
- 2) Name of gas or fluid, type of gas, design temperature, pressure (in particular instrument for High Pressure Gas Law certification).
- 3) Specific gravity of fluid, its pressure, temperature.
- 4) Dimension from bottom of flange to top of float (L1)
- 5) For hydrometer application (range of specific gravity measurement)
- 6) For interface measurement application (specific gravities of upper and lower fluid)
- 7) Additional specifications.

Note

Yamatake Corporation

Totate international Building
2-12-19 Shibuya
Shibuya-ku, Tokyo 150-8316
Japan

Tel : 81-3-3486-2310

Fax : 81-3-3486-2593



Certificate No. Q17862

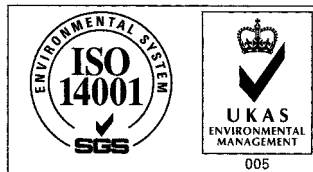

Certificate No. E8318
For Shonan Factory

YAMATAKE
Savemation

Saving through Automation