

ThermoPLUS

Advanced Temperature Transmitter

Model ATT60/70

OVERVIEW

The Advanced Temperature Transmitter (models ATT60/70) is a field instrument that converts inputs from thermocouples, mVs, and resistance thermo-bulbs into analog (4 to 20mA) and digital signals and transmits them to receivers. Various parameters can be remotely set and self-diagnosis can be performed through the Smart Field Communicator (SFC).

It can also execute two-way communications between the SFC, or HART[®] 275 communicator, and, via DE protocol, with the TDCS3000 or 3000^X and a database, thus facilitating self-diagnosis, range resetting, and automatic zero adjustment.

Easier to maintain

Settings, adjustments and self-diagnosis can be done easily by SFC.

FEATURES

Flexible sensor types

ThermoPLUS handles all thermal sensors, and any temperature range can be set as required.

Reduction in engineering work costs

The models ATT60/70's two-wire system requires no compensation wires or field cables.

Self-diagnostics function

- Abnormal ambient temperature:
Can monitor outside the range of -40 to 85°C
- Abnormal input:
When temperature sensor output fails.
- Thermocouple disconnection :
Thermocouple is disconnected.

The optimum range for a given process

Even if out of range, the necessary data can be read afterward from the holding function of the maximum and minimum PV values.

Convenient integral digital indicators

They are available as an option (0 to 100% even scale), allowing simultaneous field display indication and signal transmission.



Remote sensor type

Smart Field Communicator (Sold separately)

Type of protection

ThermoPLUS has acquired the various Explosion protection approvals, including JIS and FM.

HART[®] is a registered trademark of the HART Communication Foundation.

FUNCTIONAL SPECIFICATIONS

Type of protection

NEMA TYPE4X IP67(Dust and Water tight)

JIS Flameproof for Ex d IIC T6 (ambient temperature range -20 to 60°C)

FM Explosionproof approval

Explosionproof for Class I, Div. 1 Groups A, B, C, D
Flameproof for Class I, Zone 1, AEx d IIC T6, (ambient temperature range <80°C)
Dust-ignition proof for Class II and III, Division 1, Groups E, F, G

Input

Thermocouples (T/C)

Type J, K, T, N, S, R, E, B

Resistance thermobulbs (RTD)

Pt100, JPt100
 mV

Measuring range

Thermocouples(T/C) and Resistance thermo bulbs(RTD)

All ranges conform to JIS. For details, refer to the following table 1.

mV

-20 to 120mV

Table 1

Sensor type	Guaranteed accuracy range	Ranges that can be set by the SFC	Regulation applied
J	-50 to 1200°C	-200 to 1200°C	JIS. C1602-1995 ASTM E230-1996 IEC584-1-1995 (ITS-90)
K	-170 to 1200°C	-200 to 1370°C	
T	-120 to 400°C	-250 to 400°C	
E	-100 to 1000°C	-200 to 1000°C	
N	0 to 1300°C	-200 to 1300°C	
R	0 to 1760°C	-50 to 1760°C	
S	0 to 1700°C	-50 to 1760°C	
B	400 to 1820°C	200 to 1820°C	
Pt100	-200 to 850°C	-200 to 850°C	IEC PUB.75 (ITS-90) JIS. C1604-1997
JPt100	-200 to 640°C	-200 to 640°C	JIS. C1604-1989
mV	-20 to 120mV	-20 to 120mV	---

Burnout

Upscale (=20.8mA DC) or downscale (=3.8mA DC)

Cold junction compensation

Built-in/External cold junction compensation (selected by the SFC)

Output

Analog output (4 to 20 mA DC) with DE protocol
 Analog output (4 to 20mA DC) with HART protocol
 Digital output (DE protocol)

Supply voltage and load resistance

17 to 42 V DC / 250 to 1399Ω For details, refer to Figure 1.

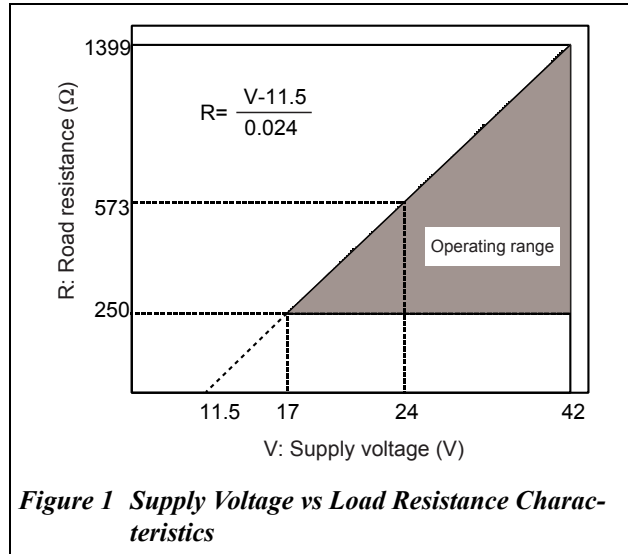

Figure 1 Supply Voltage vs Load Resistance Characteristics

Input /Output insulation characteristics

500V AC

Ambient temperature limits

Without LCD display

-40 to 85°C

With LCD display

-20 to 70°C

Ambient humidity limits

5 to 100% RH

Stability against supply voltage change

± 0.005% F.S./V

Dead time

Approx. 0.4 sec

Additional characteristics

Temperature

±0.5%F.S./(30°C)

Humidity

±0.01%F.S./(5 to 100% RH)

Supply voltage

±0.1%F.S. (at 17 to 42V DC)

Digital display

LCD display can be selected.
 LCD display is 4.5 columns engineering unit display (degree C and F), and bar graph display of output level of 4-20mA DC by bar graph.

Lightning protection

Peak value of voltage surge:100 KV
 Peak value of current surge:1000 A

Vibration characteristic (Without mounting bracket)

9 to 2000Hz 3G

PERFORMANCE SPECIFICATIONS**Conversion accuracy**

Depend on sensor type and measuring span (For details, refer to Table 1 and 2)

Total accuracy = Digital accuracy + Analog Accuracy

(Note: Digital type is Digital accuracy only.)

Table 2 Conversion accuracy

Sensor type	Digital accuracy	Analog accuracy	Minimum span
J	±0.3°C	±0.05%F.S.	25°C
K	±0.4°C		
T	±0.4°C		
E	±0.3°C		
N	±0.5°C		
R	±0.6 °C		
S	±0.6 °C		
B	±0.8 °C		
Pt100	±0.2°C		10°C
JPt100	±0.2°C		
mV	±0.05% rdg, or +/-5µV (Whichever is larger)		2mV

Note) 1. Example of accuracy calculation for analog output of measuring range, using thermocouple type J.

Setting Range : 0 to 1000°C

$$\begin{aligned} \text{Total accuracy} &= \text{Digital accuracy} + \text{Analog accuracy} \\ &= \{(0.3/1000) \times 100\} = 0.05\%F.S. \\ &= 0.03 + 0.05 \\ &= 0.08 \end{aligned}$$

Actual accuracy is less than 0.08%F.S.; ±0.8°C.

Note) 2. Example of accuracy calculation for digital output of measuring range using resistance thermobulb type Pt100.

Setting Range : 0 to 100°C

$$\begin{aligned} \text{Total accuracy} &= \text{Digital accuracy} + \text{Analog accuracy} \\ &= 0.2 + 0 = \{(0.2/100) \times 100\} + 0 \\ &= 0.2 \end{aligned}$$

Actual accuracy is less than 0.2%F.S.; ±0.2°C.

PHYSICAL SPECIFICATIONS**Finish****Standard**

Corrosion resistant paint (baked acrylic paint)

Corrosion resistant paint

Corrosion resistant paint (baked acrylic paint) and Fungus proof finish

Corrosion proof paint

Corrosion resistant paint (baked epoxy paint) and Fungus proof finish

Color

Metallic Green (Muncell's 5G7/8)

Weight

Approx 0.9 kg

INSTALLATION**Electrical connection**

G1/2, 1/2NPT internal thread, M20x1.5, Pg13.5

Mounting

Can be installed on a 2-inch horizontal or vertical pipe (can be directly mounted on a process pipe)

Process connection

Rc1/2, 1/2NPT internal thread and Rc1/4, 1/4NPT internal thread

Default selection when ordering

(Unless notify when ordering, item is set as the following value)

Type of sensor	: Pt100
Temperature	: 0 to 100°C
Output characteristic	: Linear
Damping TIME	: 0.0 sec.
Cold junction compensation	: Internal cold junction

Guidelines for product selection

- Applicable temperature range of JIS Flameproof model is from -20 to 85°C as defined by JIS Flameproof Technical Standard (Feb. 1997). The Flameproof characteristics are guaranteed only when the supplied Yamatake explosion-proof packing cable gland are used. Be aware that the explosionproof characteristics cannot be guaranteed with other manufactures' accessories.
- Vibration characteristics shown is of the ThermoPLUS's converter only, not that of the temperature element unit.
- The converter may get hot due to the radiated heat even it is installed within the operatable ambient temperature range atmosphere. Take necessary measures such as using shielding to defuse the heat so the converter can function properly

MODEL SELECTION

ThermoPLUS Advanced Temperature Transmitter

Field mounted watertight model

Basic model no.

ATT60		-	Table1	-	Table2	-	Option
Output	Analog (4 -20mA)		A				
	Digital (DE -protocol)		D				
	Analog output with HART®		H				
Housing	Water-proof and dust -proof structure		1				
Electrical connection	G1 / 2		1				
	1 / 2NPT		2				
	M20×1.5 (with adaptor)		3				
	Pg13.5 (with adaptor)		4				
Integral digital meter	Without			X			
	LCD meter for Deg. C			M			
	LCD meter for Deg. F			F			
Finish	Standard finish			S			
	Corrosion -resistant finish			A			
	Corrosion -proof finish			B			
Burnout feature	Upscale				U		
	Downscale				D		
Options	No selection					X	
	Certificate of traceability					A	
	Mounting bracket					B	
	Customer configurations (sensor type and measuring range)					C	
	Two additional wire conduits					F	
	Tropical finish					H	
	Calibration test report					T	

ThermoPLUS Advanced Temperature Transmitter

Explosionproof model

Basic model no.

ATT70

Table1

--	--	--

Table2

--	--	--

Option

--	--	--	--

Output	Analog (4 -20mA)	A
	Digital (DE -protocol)	D
	Analog output with HART®	H

Safety Approval	JIS Flameproof	2
	FM Exprosn proof	4

Electrical connection	G1 / 2 only for JIS Flame proof	1
	1 / 2NPT only for FM Exprosn proof	2

Integral digital meter	Without	X
	LCD meter for Deg. C	M
	LCD meter for Deg. F	F

Finish	Standard finish	S
	Corrosion -resistant finish	A
	Corrosion -proof finish	B

Burnout feature	Upscale	U
	Downscale	D

Options	No selection	X
	Certificate of traceability	A
	Mounting bracket	B
	Customer configurations (sensor type and measuring range)	C
	Two additional wire conduits	F
	Tropical finish	H
	Calibration test report	T

DIMENSIONS

Dimensions of converter (Separated sensor type)

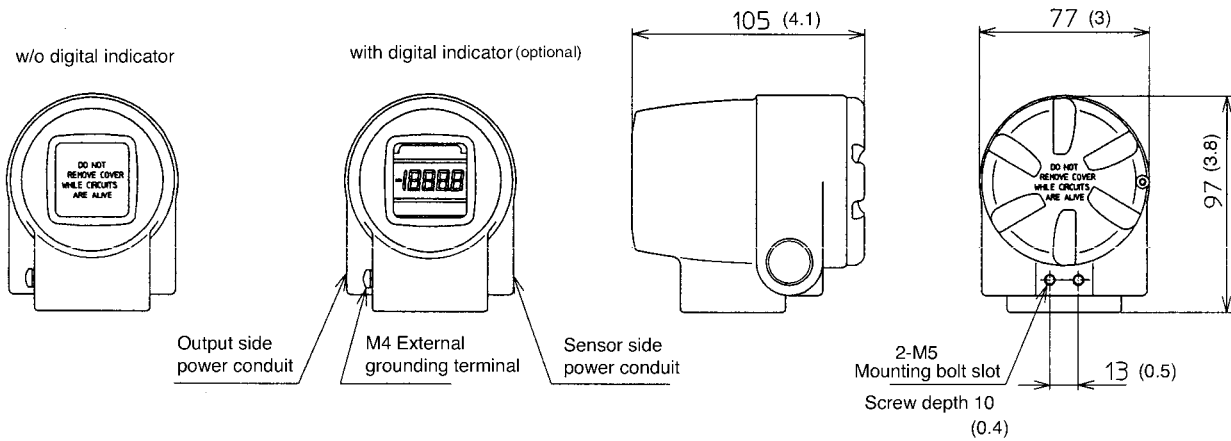

Dimension of field mounting

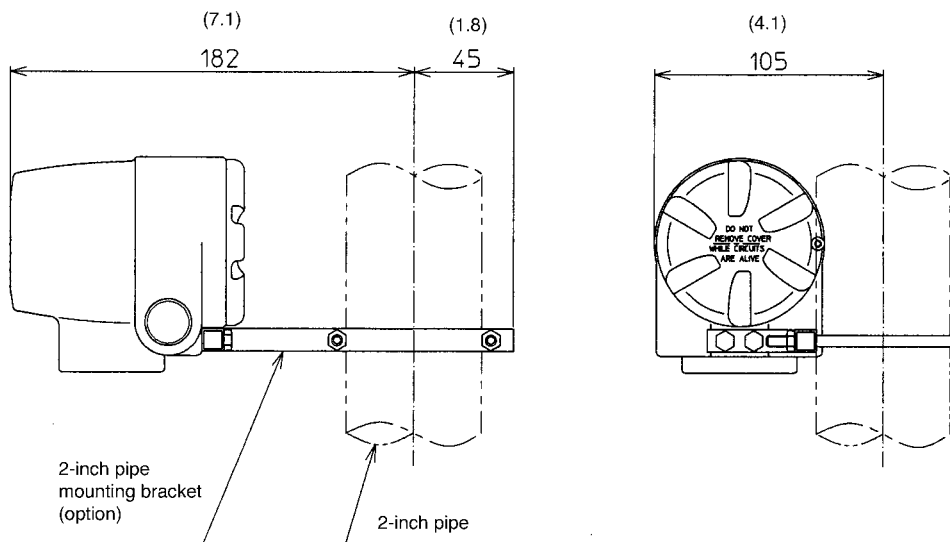

Output wiring

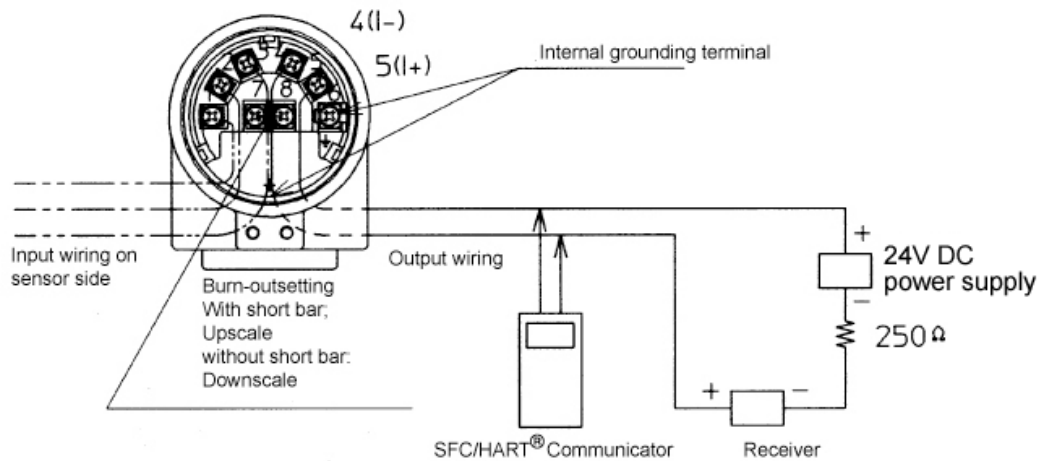

Yamatake Corporation

Totate international Building□
2-12-19 Shibuya□
Shibuya-ku, Tokyo 150-8316□
Japan
Tel : □ 81-3-3486-2310□
Fax : 81-3-3486-2593



Certificate No. Q17862

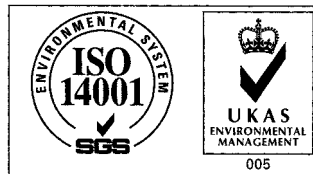

Certificate No. E8318
For Shonan Factory

YAMATAKE
Savemation
Saving through Automation